



# Filter fans 58 m<sup>3</sup>/hr



## ATV 22



Features	Unit	ATV2000	ATV2200	ATV2201	ATV2224	ATV2248
Air flow rate (free blow)	m <sup>3</sup> /h	-	58(64)		58	
Air flow rate with exit filter	m <sup>3</sup> /h	-	43(48)		43	
Power supply	V/Hz	-	230 / 50-60	115 / 50-60	24DC	48DC
Dimensions HxWxD	mm	150x150x37	150x150x86			
Power consumption	W	-	22 (21)		9	13
Current consumption	A	-	0.14 (0.12)	0.26 (0.24)	0.37	0.27
Overcurrent protection	-	-	impedance			
Electrical connection	-	-	3-poles spring terminals *		2-poles spring terminals *	
Duty cycle	-	-	100%			
Operating temperature	°C (°F)	-	-10 / +70 (+14/+158)			
Protection degree / Class	-	IP54	IP54 / Class I			
Noise level	dB(A)	-	43(49)		45	
Flow direction	-	-	reversible, default factory setting outside-in			
Bearing	-	-	ball			
Filter mat EN779	-	G3	G3			
Service life (at 40°C)	hr	-	50 000			
Material	-	-	ABS UL94V-0 color RAL7035			
Wall thickness	mm	-	1.2 - 2.4			
Gasket	-	-	foam seal gasket			
Weight (with packaging)	kg	0.18(0.23)	0.76(0.83)		0.48(0.55)	
Package dimensions H x W x D	mm	165x165x45	165x165x90			
Mounting	-	-	fast clip-on			
Conformity/Certifications	-	-	CE			

\* 0.5-2.5mm<sup>2</sup>

### Versions

UL File n. E301228 -code ending	U
EMC-code ending	M

### Accessories

Filter mat, standard type	ATVF2
Filter mat, high efficiency	ATVF2X
Thermostat 0-60°C, NO contact	THV2
Fan speed controller	FSC
Hood for IP55	CUFF10B

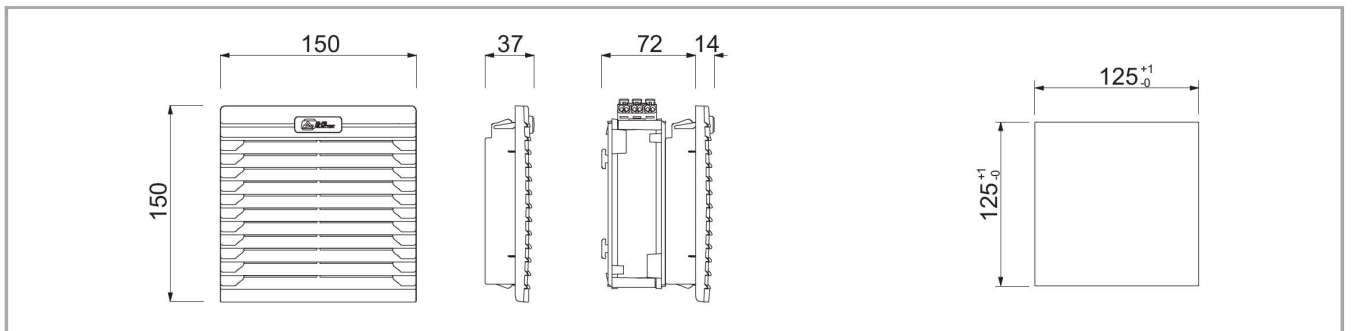

Specifications, values and drawings are subject to change without notice.