



LIGHTING

NEW SERIES

LEDLAMP 32

SLIM, HIGH EFFICIENCY ENCLOSURE LED LAMP WITH MOTION SENSOR

Wide voltage range from 20VDC up to 265VAC in a single model.

Spring terminal. More units can be connected together in a chain.

Fixing clips in each model permit to rotate the lamp according to lighting needs.

Magnet fixing or screw fixing. Motion sensor or switch ON/OFF available.

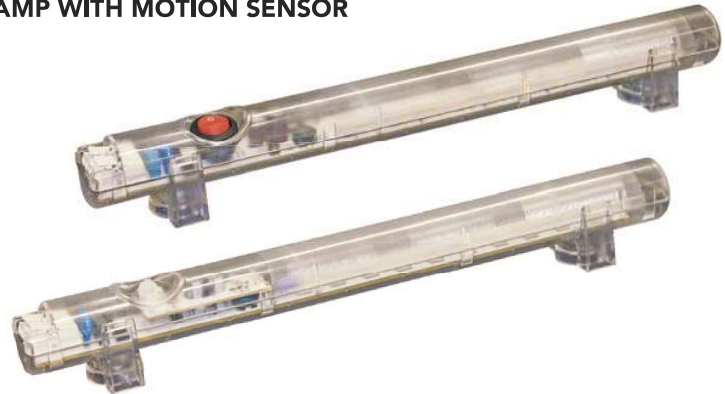

SPRING TERMINAL



MOTION SENSOR



CLIP FIXING WITH MAGNET OR SCREW



ORIENTABLE

Features	Unit	LEDLAMP3200	LEDLAMP3201	LEDLAMP3210	LEDLAMP3211
Power supply	V/Hz	24-48 VDC / 100-240 VAC 50-60 Hz			
Luminosity	Lm	400			
Lamp type	-	LED			
Power consumption	W	2,5			
Service life (@ 20°C)	hr	60 000			
Switch	-	on/off switch		Motion sensor*	
Electrical connection	-	2-poles spring terminals **			
Casing	-	Plastic			
Protection degree / Class	-	IP20 / Class II			
Operating temperature	°C (°F)	-30 / +60 (-22 / +140)			
Storage temperature	°C (°F)	-40 / +85 (-40 / +185)			
Mounting	-	screw fixing	magnet fixing	screw fixing	magnet fixing
Installation position	-	Variable			
Dimensions	mm	Ø32x345			
Weight (with packaging)	kg	0.155 (0.205)	0.175 (0.225)	0.155 (0.205)	0.175 (0.225)
Package dimensions	mm	415x50x43			
Conformity/Certifications	-	CE, File n° E301228			

* 5min switched on after last detection

** 0.5-2.5mm

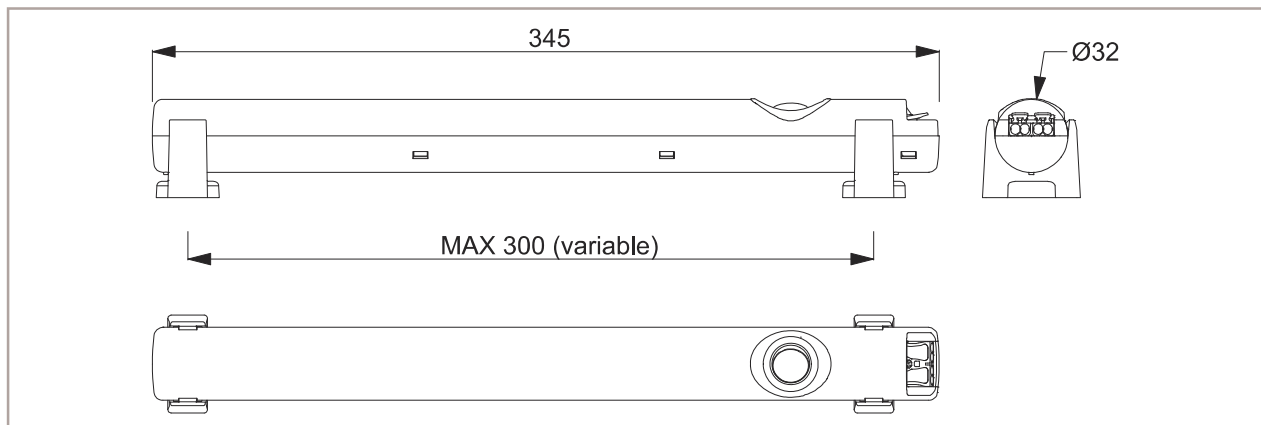

Specifications, values and drawings are subject to change without notice.