



- Three-pole versions up to 630A in IEC AC3 duty
- Four-pole versions up to 1600A in IEC AC1 duty
- Versions for power factor correction up to 100kvar at 400VAC
- Four-pole versions with 2NO+2NC or 4NC main poles
- Versions for photovoltaic application
- Versions with AC, DC or AC/DC control
- Low-consumption versions with DC control circuit for control relays and 9-38A contactors in IEC AC3 duty
- Extensive choice of add-on blocks and accessories
- Certified by primary international authorities.

	<b>SEC. - PAGE</b>
<b>Contactors</b>	
Three-pole .....	2 - 6
Four-pole .....	2 - 10
Four-pole with 2NO and 2NC poles or 4NC poles .....	2 - 14
For Photovoltaic applications .....	2 - 15
For power factor correction .....	2 - 16
Control relays .....	2 - 17
<b>Add-on blocks and accessories</b>	
For BG series mini-contactors .....	2 - 18
For BF series contactors .....	2 - 20
For B series contactors .....	2 - 30
<b>Spare parts</b>	
AC coils for BF series contactors .....	2 - 32
AC/DC and DC coils for BF series contactors .....	2 - 33
AC/DC coils for B series contactors .....	2 - 34
Main contacts for BF series contactors .....	2 - 35
Main contacts and arc chutes for B series contactors .....	2 - 35
<b>Dimensions</b> .....	<b>2 - 36</b>
<b>Wiring diagrams</b> .....	<b>2 - 51</b>
<b>Technical characteristics</b> .....	<b>2 - 56</b>



Page 2-6

**THREE-POLE CONTACTORS**

- IEC Ith ratings in AC1 duty at  $\leq 40^{\circ}\text{C}$ : 16 to 1600A
- IEC Ie ratings in AC3 440V duty: 6 to 630A
- IEC Power ratings in AC3 400V duty: 2.2 to 335kW
- UL/CSA ratings: 3 to 500HP at 480V and 600V
- AC, DC, AC/DC and DC low-consumption coil.



Page 2-10

**FOUR-POLE CONTACTORS**

- IEC Ith ratings in AC1 duty at  $\leq 40^{\circ}\text{C}$ : 20 to 1600A
- IEC Power ratings in AC1 400V duty: 14 to 950kW
- UL/CSA general use: 16 to 1000A
- AC, DC, AC/DC and DC low-consumption coil.



Page 2-14

**FOUR-POLE CONTACTORS WITH 2NO+2NC MAIN POWER POLES AND WITH 4 NC POLES**

- IEC Ith ratings in AC1 duty at  $\leq 40^{\circ}\text{C}$ : 20 to 115A for type 2NO+2NC
- UL/CSA general use: 20 to 115A
- IEC Ith ratings in AC1 duty at  $\leq 40^{\circ}\text{C}$ : 25 to 40A
- UL/CSA general use: 20 to 55A for 4NC types
- AC, DC, AC/DC and DC low-consumption coil.



Page 2-15

**CONTACTORS FOR PHOTOVOLTAIC APPLICATIONS**

- Operational current up to 350A (DC1 600V at  $\leq 55^{\circ}\text{C}$  with 4 NO poles in series) for photovoltaic applications.
- AC, and AC/DC coil.

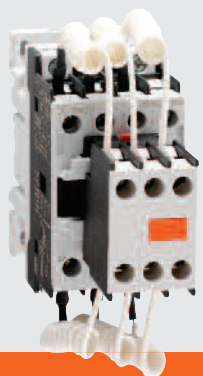

Page 2-16

**CONTACTORS FOR POWER FACTOR CORRECTION**

- With limiting resistors included
- IEC Power ratings at 400V: 7.5 to 100kvar
- UL/CSA ratings: 9 to 100kvar at 480V; 10 to 120kvar at 600V
- AC coil.



Page 2-17

**CONTROL RELAYS**

- AC, DC and DC low-consumption coil
- Screw or Faston termination
- 4, 8 or 11 auxiliary contact composition.



LOVATO Electric contactors are suitable for new motors with high IE3 efficiency values



## 2 Contactors

Contactors BF00, BF09...BF150

# THE IDEAL SOLUTION!



### 4-TERMINAL COIL

Connecting cables can be coupled to the coil both on the line and load ends of the contactor.

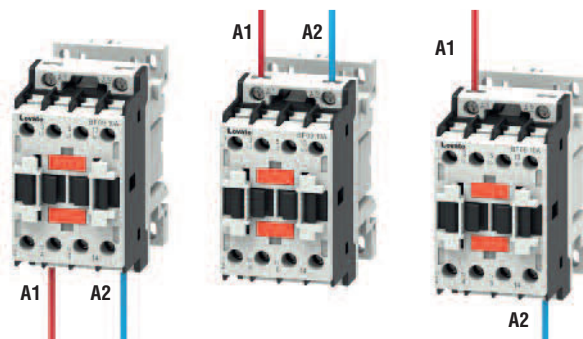

### ELECTRONIC COIL

Contactors from 40 to 150A AC3 can be equipped with AC/DC electronic coil with wide operating range. Example: single 100 to 250V AC/DC coil.

### BUILT-IN SURGE SUPPRESSOR

BF series contactors up to 150A AC3 with voltages in DC or AC/DC already have a built-in surge suppressor.

### LOW-CONSUMPTION COILS

The BF...L contactors feature a 2.4W low consumption. This characteristic widely allows their direct control by PLC outputs.

### COILS WITH WIDE OPERATING RANGE

BF...D contactors are equipped with a wide operating range coil and are particularly useful in applications subject to considerable voltage variations, such as in electric traction railway equipment.

### 45mm WIDE CONTACTORS

Ratings up to 38A in AC3 (18.5kW) 400V 30HP 480V UL - merely 45mm wide: exceptional benefit for electric panel dimensions.

### 55mm WIDE CONTACTORS

Ratings up to 95A in AC3 (45kW) 400V / 60HP 480V UL - merely 55mm wide: exceptional benefit for electric panel dimensions.

### 75mm WIDE CONTACTORS

Ratings up to 150A in AC3 (75kW) 400V / 100HP 480V UL - merely 75mm wide: exceptional benefit for electric panel dimensions.

### RAILWAY APPLICATIONS



Thanks to the compliance with IEC 61373 (shock and vibration) and EN 45545 (fire behaviour), LOVATO Electric contactors are suitable for railway applications. Consult Technical support for detailed information; see contact details on inside front cover.

### HOUSEHOLD AND COMMERCIAL APPLICATIONS



The plastic materials of the contactors comply with the EN 60335 standard typically applied in equipment for food industry and professional catering. Consult Technical support for detailed information; see contact details on inside front cover.

### PHOTOVOLTAIC APPLICATIONS



LOVATO Electric contactors are suitable for use in the various sections of the photovoltaic systems. In particular, there are specific contactors for use up to 1000VDC.





## 2 Contactors

Contactors BF00, BF09...BF150

### 35MM DIN RAIL MOUNTING AND FIXING

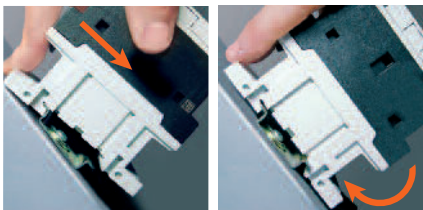

Contactor mounting on and removal from a 35mm DIN rail are tool-less operations and are done by simply applying pressure on the contactor.

### RUBBER PAD INSERT TO PREVENT DIN RAIL SLIDING

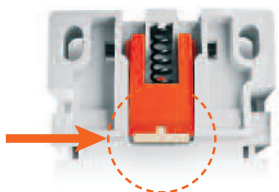

A rubber insert prevents the contactors from sliding on the 35mm DIN rail even when out of tolerance or mounted vertically.

### SNAP-ON INSTALLATION

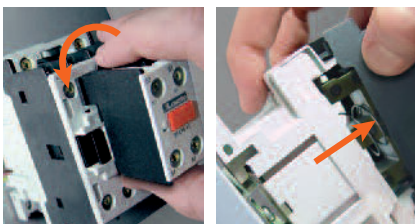

On the contactors, it's quick and easy to fit and remove auxiliary contacts and accessories, without using tools; the same applies to replacing the coil in the AC BF09...BF38 contactors.

### EFFORTLESS THERMAL OVERLOAD RELAY LINK RF38, RF82 AND RF110 TYPES

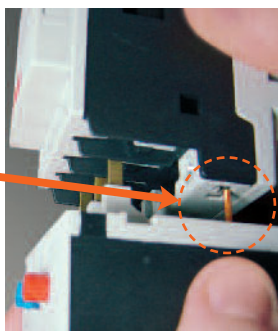

During the connection of the thermal overload relay to the contactor, its auxiliary contact is simultaneously linked to the contactor coil terminal rigid connector. The complete overload relay fixing is obtained with one single operation and without other connections.

### RIGID CONNECTION KITS FOR FAST WIRING WITHOUT MISTAKES

The assembly and wiring of electromechanical starters is extremely fast and reliable. Versatile electrical and mechanical connecting systems provide easy and foolproof assembly of compact starters and changeovers.

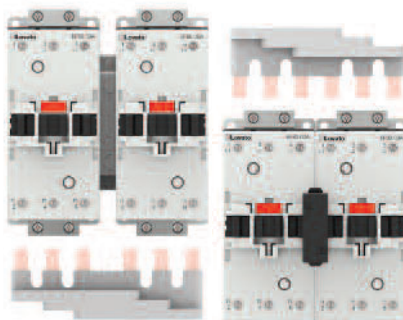

Changeover

Reversing starter

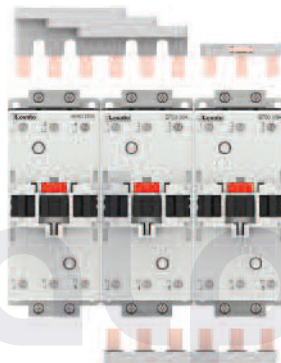

Star-delta starter

### BREAKER-CONTACTOR CONNECTIONS

The rigid connections between breaker and contactor allow complete compact starters to be created easily, quickly and with less space used in the panel. It is fitted on a single DIN rail.



### IP20 CONNECTION SECURITY

For BF09...BF38 contactors, the easy access and space for the terminals is combined with IP20 protection, preventing accidental contact with live parts.

### IP20 ACCESSORY FOR CONTACTORS FROM 40A TO 150A AC3

IP20 protection can be obtained by adding a simple accessory.



### SIDE ADD-ON FOURTH POLE

For the 45A to 165A AC1 ratings, a side-mount fourth power pole can be snapped on the three-pole contactor. This solution permits the optimisation of inventory.



### MECHANICAL INTERLOCK

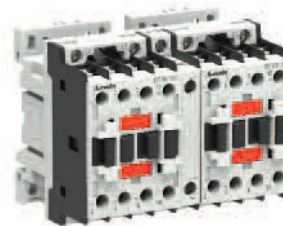

Various versions of mechanical interlock are available.

One type can be integrated in the contactors from 9 to 38A AC3 without increasing the overall dimensions.

They may have built-in contacts to also make the electrical interlock. The mounting position can be on the side or on the front of the contactors.

### TERMINAL ADAPTABILITY

Terminals are suitable for every type of cable: flexible, rigid, according to AWG standards and interlocked with any type of cable terminal. For BF09...BF38 contactors, a single type of screwdriver tightens the screws for the power contacts, auxiliary contacts and coil.

### DOUBLE LUG TERMINALS

40 to 150A AC3 contactors are equipped with double lug terminals for easy, functional access for power cables.

It is extremely simple to create star-delta starters, reversing switches, changeovers and arrange parallel supply for several contactors.







## 2 Contactors

Contactors BF160...BF230

# INNOVATION IS CONTINUING....



- **AC/DC COIL WITH ELECTRONIC CONTROL.**
  - Wide operating range: for example one single coil to cover 100...250VAC/DC range.
  - Low consumption during in-rush and in service
  - No chattering in the event of irregular voltage
  - Built-in surge suppressor filter.

- **COMPACT DIMENSIONS**
  - Three-pole contactors: 105mm width for currents up to 230A AC3 - 350A AC1
  - Four-pole contactors: 140mm width for currents up to 350A AC1
  - Width identical with moulded-case circuit breakers of equal current.

- **CONTACT STATUS FRONT VIEW**  
A front mechanical indicator allows to easily identify the status of the contacts.

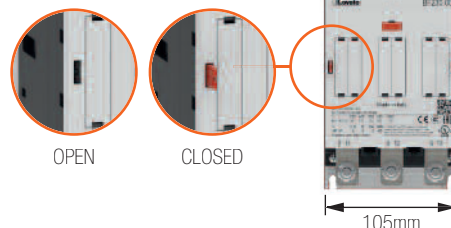

- **HIGH POWER TERMINALS FOR EASY AND SAFE WIRING**  
High terminals to ensure a safe isolation distance from the panel in case of wiring with double terminals or bars for parallel or changeover.

- **SIDE-MOUNT AUXILIARY CONTACTS**

Useful in the event that the panel depth may be critical.

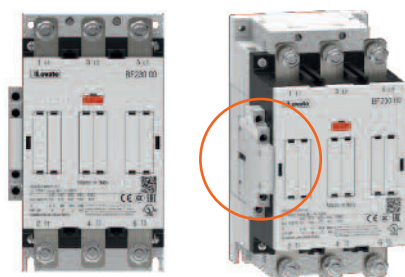

- **REVERSIBLE COIL TERMINALS BLOCK**

Easy coil terminal reversing upstream - downstream for easy wiring.

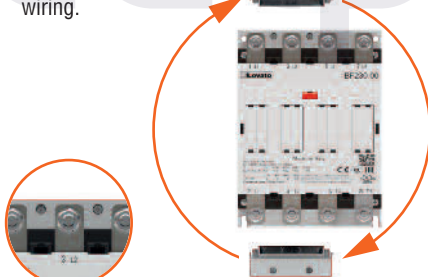

The coil terminals are easily accessible with a screwdriver as they are between the power terminals.

- **POWER TERMINAL PROTECTIONS PHASE BARRIERS.**

They guarantee the separation and protection of the power terminals and adjacent phases separation.



- **TERMINAL ENLARGEMENT**

They extend the pitch of the terminals from 35mm to 45mm to allow an easy wiring of standard flange lugs for cross-sectional cables of 185mm<sup>2</sup>.



- **FRONT-MOUNT AUXILIARY CONTACTS**

Up to 6 NO or NC auxiliary contacts, with screw or spring terminals, can be mounted without side dimensions increasing.

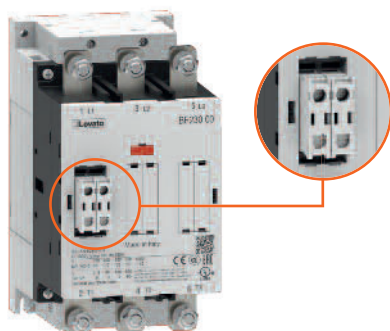

- **HORIZONTAL AND VERTICAL INTERLOCK**

Horizontal interlock with concealed mounting does not increase the dimensions.

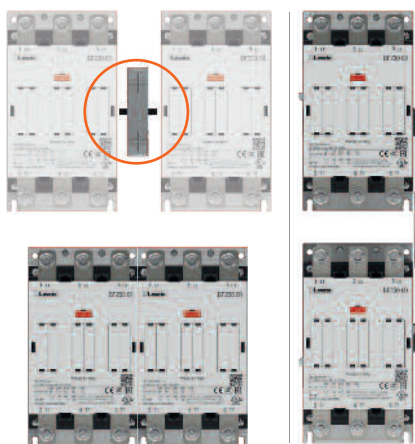

- **CAPTIVE NUT**

Accessory that allows even easier wiring of the terminals using a single wrench.

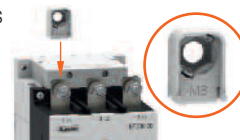

- **EASY COIL AND POWER CONTACTS REPLACEMENT**

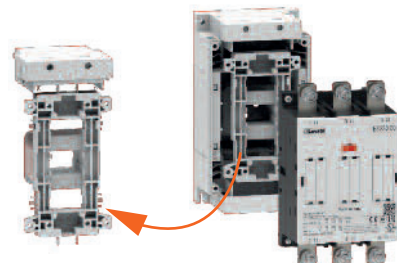



## 2 Contactors

### BG series mini-contactors



- AC and DC versions of same size
- Quick connect - snap on accessory mounting
- Distinct contact status indication
- Up to four auxiliary contacts can be mounted
- Mechanical interlock only 5mm depth
- Three-pole mini-contactors, 6 to 12A IEC AC3 duty / 3 to 7.5HP 480V - 3 to 10HP 600V UL/CSA
- Four-pole mini-contactors, 20A IEC AC1 duty
- Versions with 2NO+2NC main power poles
- Highly conductive auxiliary contacts with four contact points
- Coils with AC or DC supply
- Low-consumption DC versions
- Screw, faston and rear PCB solder pin termination.

	3 poles			4 poles		
	le (AC3)	AC	DC	lth (AC1)	AC	DC
BG06	6A	●	●	—	—	—
BG09	9A	●	●	20A	●	●
BGF09	9A	●	●	20A	●	●
BGP09	9A	●	●	20A	●	●
BG12	12A	●	●	—	—	—

### BF series contactors

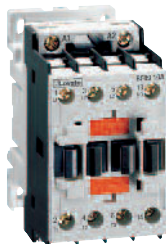

- Quick connect - snap on accessory mounting
- Distinct contact status indication
- Up to eight auxiliary contacts can be mounted
- Mechanical interlock without overall dimensions increasing
- Three-pole contactors, 9 to 230A IEC AC3 duty / 5 to 150HP 480V - 7.5 to 200HP 600V UL/CSA
- Four-pole contactors, 25 to 350A in AC1 duty
- Power factor correction contactors, 7.5 to 100kvar at 400V IEC / 9 to 110kvar at 480V UL/CSA
- Types with 2NO+2NC or 4NC main power poles
- Types for photovoltaic applications
- Highly conductive auxiliary contacts
- Coils with AC or DC supply
- Wide-range coils with electronic control for contactors from 40 to 230A AC3
- Low-consumption versions for control relays and 9-38A contactors in IEC AC3 duty.
- Screw terminals.

	le (AC3)	3 poles with coil type:			
		AC	DC	DC <sup>①</sup>	AC/DC <sup>②</sup>
BF09	9A	●	●	●	—
BF12	12A	●	●	●	—
BF18	18A	●	●	●	—
BF25	25A	●	●	●	—
BF26	26A	●	●	●	—
BF32	32A	●	●	●	—
BF38	38A	●	●	●	—
BF40	40A	●	—	—	●
BF50	50A	●	—	—	●
BF65	65A	●	—	—	●
BF80	80A	●	—	—	●
BF94	95A	●	—	—	●
BF95	95A	●	—	—	●
BF115	115A	●	—	—	●
BF150	150A	●	—	—	●
BF160	160A	—	—	—	●
BF195	195A	—	—	—	●
BF230	230A	—	—	—	●

	lth (AC1)	4 poles with coil type:			
		AC	DC	DC <sup>①</sup>	AC/DC <sup>②</sup>
BF09	25A	●	●	●	—
BF12	28A	●	—	—	—
BF18	32A	●	●	●	—
BF26	45A	●	●	●	—
BF38	56A	●	●	●	—
BF40	70A	●	—	—	—
BF50	90A	●	—	—	—
BF65	100A	●	—	—	●
BF80	115A	●	—	—	●
BF95	140A	●	—	—	●
BF115	160A	●	—	—	●
BF150	165A	●	—	—	●
BF160	250A	—	—	—	●
BF195	275A	—	—	—	●
BF230	350A	—	—	—	●

- ① Low-consumption version.
- ② Wide-range coil with electronic control.

### B series contactors



- 3 frame sizes offering 8 different contactors
- Coil operates indifferently on AC or DC supply voltage
- Coil with low in-rush and holding
- Coil removable without disconnecting power wiring
- Red indicator when contactor is energised
- Safety feature prevents contactor to be energised without arc chute in place and locked
- Convertible auxiliary contact block (2NO + 1NC or 1NO + 2NC), maximum of 4 blocks per contactor for a total of 12 contacts
- Contactor terminals with bolt, washer and nut
- Simple horizontal or vertical interlock
- Three-pole contactors, 265A to 630A IEC AC3 duty
- Four-pole contactors, 350A to 1600A IEC AC1 duty
- 100 to 500HP 600V UL/CSA
- Coils with AC/DC supply
- Screw termination.

	3 poles			4 poles		
	le (AC3)	AC	AC/DC	lth (AC1)	AC	AC/DC
B250	265A	—	●	350A	—	●
B310	320A	—	●	450A	—	●
B400	420A	—	●	550A	—	●
B500	520A	—	●	700A	—	●
B630	630A	—	●	800A	—	●
B6301000	①	—	●	1000A	—	●
B1250	①	●	—	1250A	●	—
B1600	①	●	—	1600A	●	—

- ① For AC1 / general use duty only.



# 2 Contactors

Three-pole contactors with AC control circuit



Three-phase motor control in AC3 duty

Order code	IEC operating current				Maximum IEC power at ≤55°C (AC3)								UL/CSA details				
	Ith (AC1)			Ie (AC3)	230V	400V	415V	440V	500V	690V	1000V	Maximum UL/CSA horsepower ratings		Three phase			
AC coil	≤40°C	≤55°C	≤70°C	≤440V at ≤55°C	230V	400V	415V	440V	500V	690V	1000V	Single phase	200V	240V	480V	600V	
[A]	[A]	[A]	[A]	[A]	[kW]	[kW]	[kW]	[kW]	[kW]	[kW]	[kW]	[HP]	[HP]	[HP]	[HP]	[HP]	
11BG0601A	16	14	12	6	1.5	2.2	2.4	2.5	3	3	—	1/3	1	1 1/2	2	3	
11BG0610A	—	—	—	—	—	—	—	—	—	—	—	—	—	—	—	—	
11BG0901A	20	18	15	9	2.2	4	4.3	4.5	5	5	—	1/2	1 1/2	2	3	5	
11BG0910A	—	—	—	—	—	—	—	—	—	—	—	—	—	—	—	—	
11BGF0901A	20	18	15	9	2.2	4	4.3	4.5	5	5	—	1/2	1 1/2	2	3	5	
11BGF0910A	—	—	—	—	—	—	—	—	—	—	—	—	—	—	—	—	
11BGP0901A	20	18	15	9	2.2	4	4.3	4.5	5	—	—	1/2	1 1/2	2	3	5	
11BGP0910A	—	—	—	—	—	—	—	—	—	—	—	—	—	—	—	—	
11BG1201A	20	18	15	12	3.2	5.7	6.2	5.5	5	5	—	1/2	1 1/2	3	3	7 1/2	
11BG1210A	—	—	—	—	—	—	—	—	—	—	—	—	—	—	—	—	
BF0901A	25	20	18	9	2.2	4.2	4.5	4.8	5.5	7.5	—	3/4	2	3	3	5	
BF0910A	—	—	—	—	—	—	—	—	—	—	—	—	—	—	—	—	
BF1201A	28	23	20	12	3.2	5.7	6.2	6.2	7.5	10	—	1	2	5	5	7 1/2	
BF1210A	—	—	—	—	—	—	—	—	—	—	—	—	—	—	—	—	
BF1801A	32	26	23	18	4	7.5	9	9	10	10	—	1	3	5	5	10	
BF1810A	—	—	—	—	—	—	—	—	—	—	—	—	—	—	—	—	
BF2501A	32	26	23	25	7	12.5	13.4	13.4	15	11	—	2	3	7 1/2	7 1/2	15	
BF2510A	—	—	—	—	—	—	—	—	—	—	—	—	—	—	—	—	
BF2600A	45	36	32	26	7.3	13	14	14	15.6	18.5	—	2	5	7 1/2	7 1/2	15	
BF3200A	56	45	40	32	8.8	16	17	17	20	22	—	3	7 1/2	10	10	20	
BF3800A	56 (60)	45 (48)	40 (42)	38	11	18.5	18.5	18.5	20	22	—	3	7 1/2	10	15	30	
BF4000A	70	60	50	40	11	18.5	22	22	22	30	18.5	3	7 1/2	10	15	30	
BF5000A	90	75	65	50	15	22	30	30	30	37	22	5	10	15	20	40	
BF6500A	100	80	70	65	18.5	30	37	37	37	45	30	—	—	20	25	50	
BF8000A	115	95	80	80	22	45	45	45	55	55	37	—	—	25	30	60	
BF9400A	115	95	80	95	30	55	55	55	55	55	37	—	—	25	30	60	
BF9500A	140	115	100	95	30	55	55	55	75	90	45	—	—	30	30	60	
BF11500A	160	130	115	115	37	55	55	55	75	110	55	—	—	40	40	75	
BF15000A	165	135	118	150	45	75	75	75	90	110	55	—	—	50	50	100	
BF16000E	250	210	180	160	45	75	90	90	110	132	75	—	—	50	60	125	
BF19500E	275	230	200	195	55	90	110	110	132	160	90	—	—	60	75	150	
BF23000E	350	290	250	230	55	110	110	132	132	160	110	—	—	75	75	150	
11B25000E	350	300	250	265	83	140	155	164	176	212	156	—	—	75	100	200	
11B31000E	450	370	300	320	100	170	188	200	213	256	180	—	—	100	125	250	
11B40000E	550	430	360	420	130	225	247	263	271	352	208	—	—	125	150	350	
11B50000E	700	550	500	520	156	290	306	328	367	416	312	—	—	150	200	400	
11B63000E	800	640	540	630	198	355	368	368	368	440	368	—	—	200	250	500	
11B63010000E	1000	850	700	—	For AC1/Resistive duty only. see page 2-8.						—	—	—	—	—	—	—
11B125024E	1250	1050	880	—	For AC1/Resistive duty only. see page 2-8.						No UL	—	—	—	—	—	—
11B160024E	1600	1360	1120	—	For AC1/Resistive duty only. see page 2-8.						No UL	—	—	—	—	—	—

1 Complete order code with coil voltage digit or with voltage digit followed by 60 (if 60Hz). Standard voltages are as follows:  
 - AC 50/60Hz 024 / 048 / 110 / 230 / 400V  
 - AC 60Hz 024 60 / 048 60 / 120 60 / 220 60 / 230 60 / 460 60 / 575 60 (V).  
 Example: 11BG0610A230 for mini-contactor BG06, three poles, with one NO contact and 230VAC 50/60Hz coil.  
 11BG0610A460 60 for mini-contactor BG06 with one NO contact and 460VAC 60Hz coil.

2 The coil of the contactor can be powered differently in AC or DC. Complete the order code only with the digit of the coil voltage. Standard voltages are:  
 - AC/DC 24 / 48 / 60 / 110-125 (indicate 110) / 220-240 (indicate 220) / 380-415 (indicate 380) / 440-480V (indicate 440).  
 Example: 11B25000110 for contactor B250, three poles, without auxiliary contacts and with 110-125VAC/DC coil.  
**The 24VAC/DC voltage is not possible for B500...B6301000 contactors.**  
 Other voltages available on request.

3 If predisposed for mechanical latch (G495), the order code becomes 11B...SL00 2  
 If already fitted with mechanical latch (G495), the order code becomes 11B...L00 2 4  
 4 Indicate rated voltage of the mechanical latch, preceded by the letter C if in DC. Available voltages are:  
 - AC 50/60Hz 48 / 110-125 indicate 110 / 220-240 indicate 220 / 380-415V indicate 380  
 - DC 48 / 110-125 indicate 110 / 220-240V indicate 220.  
 Example: 11B250L0010220 for contactor B250 without auxiliary contacts, with 110-125VAC/DC coil and mechanical latch powered at 220-240VAC.

5 G495 mechanical latch cannot be mounted.  
 6 Complete the order code with the digit of the coil voltage. For 110-125VAC (50/60Hz) indicate 110 or 220-240VAC (50/60Hz) indicate 220.  
 Example: 11B125024110 for contactor B1250, three poles, with 2NO+4NC auxiliary contacts and 110-125VAC 50/60Hz coil.  
 7 Maximum voltage is limited at 300V for UL. For certified type up to 600V, consult Technical support for information; see contact details on inside front cover.  
 8 For voltages 024 / 230 / 400VAC 50-60Hz: 10 pieces/package.  
 For all other voltages: 1 piece/package.  
 9 Highly conductive auxiliary contact.



# 2 Contactors

Three-pole contactors with AC control circuit



B500-B630



B6301000

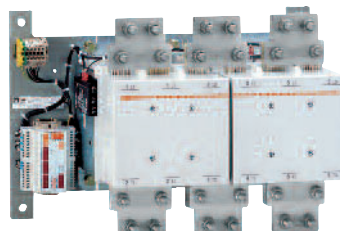

B1250-B1600

UL/CSA General (purpose) use	UL/CSA Short-circuit protection fuse, 600V		Standard fault		Type of terminal	Incorporated auxiliary contacts		Qty per pkg	Wt
	High fault Short circuit current	Fuse	Short circuit current	Fuse		NO	NC		
[A]	[kA]	[A]	[kA]	[A]			n°	[kg]	
16	100	30 (J)	5	30	Clamp-screw	— 1Ⓜ	10	0.180	
						1Ⓜ —	10	0.180	
20	100	30 (J)	5	30	Clamp-screw	— 1Ⓜ	10	0.180	
						1Ⓜ —	10	0.180	
20	100	30 (J)	5	30	Faston	— 1Ⓜ	10	0.180	
						1Ⓜ —	10	0.180	
20	100	30 (J)	5	30	Rear PCB solder pin	— 1Ⓜ	10	0.197	
						1Ⓜ —	10	0.197	
20	100	30 (J)	5	30	Clamp-screw	— 1Ⓜ	10	0.180	
						1Ⓜ —	10	0.180	
25	100	30 (J)	5	60	Clamp-screw	— 1Ⓜ	1	0.367	
						1Ⓜ —	Ⓜ	0.367	
28	100	30 (J)	5	70	Clamp-screw	— 1Ⓜ	1	0.367	
						1Ⓜ —	Ⓜ	0.367	
32	100	60 (J)	5	80	Clamp-screw	— 1Ⓜ	1	0.367	
						1Ⓜ —	Ⓜ	0.367	
32	100	60 (J)	5	100	Clamp-screw	— 1Ⓜ	1	0.367	
						1Ⓜ —	Ⓜ	0.367	
45	100	100 (J)	5	100	Clamp-screw	— —	1	0.437	
55	100	100 (J)	5	125	Clamp-screw	— —	1	0.437	
55	100	100 (J)	5	150	Clamp-screw	— —	1	0.437	
70	100	150 (J)	5	150 (RK5)	Double lug-clamp	— —	1	1.020	
90	100	150 (J)	5	150 (RK5)	Double lug-clamp	— —	1	1.020	
100	100	200 (J)	10	200 (RK5)	Double lug-clamp	— —	1	1.020	
115	100	200 (J)	10	200 (RK5)	Double lug-clamp	— —	1	1.020	
115	100	200 (J)	10	200 (RK5)	Double lug-clamp	— —	1	1.020	
140	100	200 (J)	10	250 (RK5)	Double lug-clamp	— —	1	2.020	
160	100	200 (J)	10	250 (RK5)	Double lug-clamp	— —	1	2.020	
165	100	200 (J)	10	250 (RK5)	Double lug-clamp	— —	1	2.020	
250	100	400 (J)	10	400 (RK5)	Screw-nut	— —	1	3.000	
275	100	400 (J)	10	400 (RK5)	Screw-nut	— —	1	3.000	
350	100	400 (J)	10	400 (RK5)	Screw-nut	— —	1	3.000	
350	—	—	18	800 (L)	Screw-nut	— —	1	9.575	
450	—	—	18	800 (L)	Screw-nut	— —	1	9.575	
550	—	—	18	800 (L)	Screw-nut	— —	1	9.575	
700	—	—	18 Ⓜ	1200 (L)	Screw-nut	— —	1	18.000	
800	—	—	18 Ⓜ	1500 (L)	Screw-nut	— —	1	18.620	
1000	—	—	18 Ⓜ	1500 (L)	Screw-nut	— —	1	21.400	
No UL	—	—	—	—	Screw-nut	2 4	1	48.000	
No UL	—	—	—	—	Screw-nut	2 4	1	50.000	

Ⓜ For use at this other current value, a 16mm<sup>2</sup> cable, headed with a fork terminal, must be used.  
 Ⓜ No UL/CSA ratings; data given for indication and reference purposes only.  
 Ⓜ Definite-purpose (DP) contactors are available. Consult Technical support for information; see contact details on inside front cover.  
 Ⓜ The contactor coil is controlled electronically; it can have either an AC or a DC supply and has a wide operating range.  
 Complete the order code only with the digit of the coil voltage.  
 Standard voltages are:  
 - AC/DC 024 = 24...60VAC/20...60VDC; 110 = 60...130VAC/DC; 230 = 100...250VAC/DC;  
 400 = 250...500VAC/DC.  
 Ⓜ The values in brackets indicate the class of the fuse to be used.  
 Where there is no value in brackets, any type of fuse can be used.  
 For protection with motor protection circuit breaker (type F combination motor controller) see chapter 1.

### Certifications and compliance

Certifications obtained:

Type	C U L u s	U L	C S A	E A C	C C C	Register of shipping	
						R I N A	L R O S
BG06A	●			●	●		
BG09A	●			●	●		
BG12A	●			●	●		
BGF09A	●			●	●		
BGP...AⓂ	●			●	●		
BF09A	●		●	●	●	●	
BF12A	●		●	●	●	●	
BF18A	●		●	●	●	●	
BF25A	●		●	●	●	●	
BF26A	●		●	●	●	●	
BF32A	●		●	●	●	●	
BF38A	●		●	●	●	●	
BF40A	●			●	●	●	
BF50A	●			●	●	●	
BF65A	●			●	●	●	
BF80A	●			●	●	●	
BF94A	●						
BF95A	●						●
BF115A	●						●
BF150A	●						●
B160	●			Ⓜ	Ⓜ		
B195	●			Ⓜ	Ⓜ		
B230	●			Ⓜ	Ⓜ		
B250	●	●	●	●	●	●	●
B310	●	●	●	●	●	●	●
B400	●	●	●	●	●	●	●
B500	●			●			
B630	●			●			
B6301000	●			●			
B1250				●			
B1600				●			

● Certified products.

UL - UL Listed, for USA and Canada (cULus - File E93602) for BG...BF150 types indicated, as Motor Controllers - Contactors, except for BGP09... types which are UL Recognized, for USA and Canada (File E93602 - Component - Products having this type of marking are intended for use as components of complete workshop-assembled equipment).  
 BGP is UL rated up to 300V; for type with rating up to 600V, consult Technical support for information - see contact details on inside front cover.  
 UL Listed for USA only (File E93602) for B250...B400 types indicated, as Motor Controllers - Contactors.  
 UL Listed for USA and Canada (cULus - File E172189) for B500...B6301000 and B500SL... B630SL types as Industrial Control Switches.  
 CSA - BF09...BF95 and B250...B400 contactors are also CSA certified, for Canada only (File 54332).  
 In addition, BF12... BF25... and BF38... types are CSA certified as "Elevator Equipment" (File 54332, class 2411); BF65 is UL certified as "Elevator Equipment" (File E 93602).  
 See technical characteristics on page 2-70.

Ⓜ This contactor has also achieved elevator equipment certification.  
 Ⓜ Pending.

Compliant with standards: IEC/EN/BS 60947-1, IEC/EN/BS 60947-4-1, UL508, CSA C22.2 n° 14; UL 60947-1, UL 60947-4-1, CSA C22.2 n° 60947-1, CSA C22.2 n° 60947-4-1. Plastic materials are compliant with standards IEC/EN/BS 60335; for all BF09...BF38 versions only, add suffix V260 to the standard product order code.  
 Example: BF0910A230V260 for BF09, three poles, with one NO contact and 230V 50/60Hz coil with compliant plastic materials.



## 2 Contactors

Three-pole contactors with DC and AC/DC control circuit



BG06D...BG12D  
BG09L



BF09D...BF25D  
BF09L...BF25L



BF26D-BF38D  
BF26L-BF38L



BF40E...BF94E



BF95E...BF150E

new



BF160E...BF230E



B250...B400

Order code		Three-phase motor control										UL/CSA details						
DC coil	DC coil	IEC operating current I <sub>th</sub> (AC1)			I <sub>e</sub> (AC3) ≤440V at ≤55°C	Maximum IEC power at ≤55°C (AC3)						Maximum UL/CSA horsepower ratings						
	Low consumption	≤40°C	≤55°C	≤70°C		230V	400V	415V	440V	500V	690V	1000V	Single phase		Three phase			
		[A]	[A]	[A]	[A]	[kW]	[kW]	[kW]	[kW]	[kW]	[kW]	[HP]	[HP]	[HP]	[HP]	[HP]	[HP]	
11BG0601D	—	16	14	12	6	1.5	2.2	2.4	2.5	3	3	—	1/3	1	1 1/2	2	3	3
11BG0610D	—	—	—	—	—	—	—	—	—	—	—	—	—	—	—	—	—	—
11BG0901D	11BG0901L	20	18	15	9	2.2	4	4.3	4.5	5	5	—	1/2	1 1/2	2	3	5	5
11BG0910D	11BG0910L	—	—	—	—	—	—	—	—	—	—	—	—	—	—	—	—	—
11BGF0901D	11BGF0901L	20	18	15	9	2.2	4	4.3	4.5	5	5	—	1/2	1 1/2	2	3	5	5
11BGF0910D	11BGF0910L	—	—	—	—	—	—	—	—	—	—	—	—	—	—	—	—	—
11BGP0901D	—	20	18	15	9	2.2	4	4.3	4.5	5	—	—	1/2	1 1/2	2	3	5	—
11BGP0910D	—	—	—	—	—	—	—	—	—	—	—	—	—	—	—	—	—	—
11BG1201D	—	20	18	15	12	3.2	5.7	6.2	5.5	5	5	—	1/2	1 1/2	3	3	7 1/2	10
11BG1210D	—	—	—	—	—	—	—	—	—	—	—	—	—	—	—	—	—	—
BF0901D	BF0901L	25	20	18	9	2.2	4.2	4.5	4.8	5.5	7.5	—	3/4	2	3	3	5	7 1/2
BF0910D	BF0910L	—	—	—	—	—	—	—	—	—	—	—	—	—	—	—	—	—
BF1201D	BF1201L	28	23	20	12	3.2	5.7	6.2	6.2	7.5	10	—	1	2	5	5	7 1/2	10
BF1210D	BF1210L	—	—	—	—	—	—	—	—	—	—	—	—	—	—	—	—	—
BF1801D	BF1801L	32	26	23	18	4	7.5	9	9	10	10	—	1	3	5	5	10	15
BF1810D	BF1810L	—	—	—	—	—	—	—	—	—	—	—	—	—	—	—	—	—
BF2501D	BF2501L	32	26	23	25	7	12.5	13.4	13.4	15	11	—	2	3	7 1/2	7 1/2	15	15
BF2510D	BF2510L	—	—	—	—	—	—	—	—	—	—	—	—	—	—	—	—	—
BF2600D	BF2600L	45	36	32	26	7.3	13	14	14	15.6	18.5	—	2	5	7 1/2	7 1/2	15	20
BF3200D	BF3200L	56	45	40	32	8.8	18	17	17	20	22	—	3	7 1/2	10	10	20	25
BF3800E	BF3800L	56 (60) 45 (48) 40 (42)	38	—	—	11	18.5	18.5	18.5	20	22	—	3	7 1/2	10	15	30	30
BF4000E	—	70	60	50	40	11	18.5	22	22	22	30	18.5	3	7 1/2	10	15	30	30
BF5000E	—	90	75	65	50	15	22	30	30	30	37	22	5	10	15	20	40	40
BF6500E	—	100	80	70	65	18.5	30	37	37	37	45	30	—	—	20	25	50	60
BF8000E	—	115	95	80	80	22	45	45	45	55	55	37	—	—	25	30	60	75
BF9400E	—	115	95	80	95	30	55	55	55	55	55	37	—	—	25	30	60	75
BF9500E	—	140	115	100	95	30	55	55	55	75	90	45	—	—	30	30	60	75
BF11500E	—	160	130	115	115	37	55	55	55	75	110	55	—	—	40	40	75	100
BF15000E	—	165	135	118	150	45	75	75	75	90	110	55	—	—	50	50	100	125
BF16000E	—	250	210	180	160	45	75	90	90	110	132	75	—	—	50	60	125	150
BF19500E	—	275	230	200	195	55	90	110	110	132	160	90	—	—	60	75	150	150
BF23000E	—	350	290	250	230	55	110	110	132	132	160	110	—	—	75	75	150	200
11B25000E	—	350	300	250	265	83	140	155	164	176	212	156	—	—	75	100	200	250
11B31000E	—	450	370	300	320	100	170	188	200	213	256	180	—	—	100	125	250	300
11B40000E	—	550	430	360	420	130	225	247	263	271	352	208	—	—	125	150	350	400
11B50000E	—	700	550	500	520	156	290	306	328	367	416	312	—	—	150	200	400	450
11B63000E	—	800	640	540	630	198	335	368	368	368	440	368	—	—	200	250	500	500
11B630100000E	—	1000	850	700	—	For AC1/Resistive duty only, see page 2-8.						—	—	—	—	—	—	—

- Complete order code with coil voltage digit.  
For BG09...D 24VDC version complete with built-in surge suppressor, add suffix **V120** to the standard order code.  
The BF09-BF38D types already have a standard supplied built-in TVS (Transient Voltage Suppressor). Standard voltages are as follows:  
- DC 012 / 024 / 048 / 060 / 110 / 125 / 220V.  
Example: 11BG0610D012 for mini-contactor BG06, three poles, with one NO contact and 12VDC coil.  
11BG0910D024 V120 for mini-contactor BG09, three poles, with one NO contact and 24VDC coil, complete with built-in TVS (diode) suppressor.
- Low-consumption version.  
No add-on auxiliary contacts or mechanical interlock can be mounted on BG... type contactors. Complete order code with coil voltage digit.  
The BF09-BF38L types already have a standard supplied built-in TVS (Transient Voltage Suppressor). Standard voltages are as follows:  
- DC 024 / 048V.  
Example: 11BG0901L024 for mini-contactor BG09, three poles, with one NC contact and 24VDC low-consumption coil.
- The contactor coil is controlled electronically; it can have either an AC or a DC supply and has a wide operating range.  
The order code must be completed with the coil voltage digit.

- The standard voltages are as follows:  
- AC/DC 024 = 20...48V; 110 = 60...110V; 230 = 100...250V.
- The coil of the contactor can be powered indifferently in AC or DC. Complete the order code only with the digit of the coil voltage.  
Standard voltages are:  
- AC/DC 24 / 48 / 60 / 110-125 (indicate 110) / 220-240 (indicate 220) / 380-415 (indicate 380) / 440-480V (indicate 440).  
Example: 11B25000110 for contactor B250, three poles, without auxiliary contacts and with 110-125VAC/DC coil.
- The 24VAC/DC voltage is not possible for B500...B6301000 contactors.  
Other voltages available on request.
- If predisposed for mechanical latch (G495), the order code becomes 11B...SL00.
- If already fitted with mechanical latch (G495), the order code becomes 11B...L00.
- Indicate rated voltage of the mechanical latch, preceded by the letter C if in DC.  
Standard voltages are:  
- AC 50/60Hz 48 / 110-125 indicate 110 / 220-240 indicate 220 / 380-415V indicate 380  
- DC 48 / 110-125 indicate 110 / 220-240V indicate 220.  
Example: 11B25000110C48 for contactor B250, three poles, without auxiliary contacts, with 110-125VAC/DC coil and mechanical latch powered at 48VDC.



## 2 Contactors

Three-pole contactors with DC and AC/DC control circuit



B500-B630



B6301000

UL/CSA General (purpose) use	UL/CSA Short-circuit protection fuse, 600V <sup>14</sup>					Type of terminal	Incorporated auxiliary contacts	Qty per pkg	Wt
	High fault		Standard fault						
	Short circuit current	Fuse	Short circuit current	Fuse	Fuse				
[A]	[kA]	[A]	[kA]	[A]		NO	NC	n°	[kg]
16	100	30 (J)	5	30	Clamp-screw	— 1 <sup>ⓐ</sup>	—	10	0.214
20	100	30 (J)	5	30	Clamp-screw	1 <sup>ⓐ</sup> —	—	10	0.214
						— 1 <sup>ⓐ</sup>	—	10	0.214
20	100	30 (J)	5	30	Faston	— 1 <sup>ⓐ</sup>	—	10	0.210
						1 <sup>ⓐ</sup> —	—	10	0.210
20	100	30 (J)	5	30	Rear PCB solder pin	— 1 <sup>ⓐ</sup>	—	10	0.240
						1 <sup>ⓐ</sup> —	—	10	0.240
20	100	30 (J)	5	30	Clamp-screw	— 1 <sup>ⓐ</sup>	—	10	0.214
						1 <sup>ⓐ</sup> —	—	10	0.214
25	100	30 (J)	5	60	Clamp-screw	— 1 <sup>ⓐ</sup>	—	1	0.494
						1 —	—	1	0.494
28	100	30 (J)	5	70	Clamp-screw	— 1 <sup>ⓐ</sup>	—	1	0.494
						1 —	—	1	0.494
32	100	60 (J)	5	80	Clamp-screw	— 1 <sup>ⓐ</sup>	—	1	0.494
						1 —	—	1	0.494
32	100	60 (J)	5	100	Clamp-screw	— 1 <sup>ⓐ</sup>	—	1	0.494
						1 —	—	1	0.494
45	100	100 (J)	5	100	Clamp-screw	— —	—	1	0.559
55	100	100 (J)	5	125	Clamp-screw	— —	—	1	0.559
55	100	100 (J)	5	150	Clamp-screw	— —	—	1	0.559
70	100	150 (J)	5	150 (RK5)	Double lug-clamp	— —	—	1	1.050
90	100	150 (J)	5	150 (RK5)	Double lug-clamp	— —	—	1	1.050
100	100	200 (J)	10	200 (RK5)	Double lug-clamp	— —	—	1	1.050
115	100	200 (J)	10	200 (RK5)	Double lug-clamp	— —	—	1	1.050
115	100	200 (J)	10	200 (RK5)	Double lug-clamp	— —	—	1	1.050
140	100	200 (J)	10	250 (RK5)	Double lug-clamp	— —	—	1	2.060
160	100	200 (J)	10	250 (RK5)	Double lug-clamp	— —	—	1	2.060
165	100	200 (J)	10	250 (RK5)	Double lug-clamp	— —	—	1	2.060
250	100	400 (J)	10	400 (RK5)	Screw-nut	— —	—	1	3.000
275	100	400 (J)	10	400 (RK5)	Screw-nut	— —	—	1	3.000
350	100	400 (J)	10	400 (RK5)	Screw-nut	— —	—	1	3.000
350	—	—	18	800 (L)	Screw-nut	— —	—	1	9.635
450	—	—	18	800 (L)	Screw-nut	— —	—	1	9.635
500	—	—	18	800 (L)	Screw-nut	— —	—	1	9.635
700 <sup>ⓑ</sup>	—	—	18 <sup>ⓑ</sup>	1200 (L)	Screw-nut	— —	—	1	18.060
800 <sup>ⓑ</sup>	—	—	18 <sup>ⓑ</sup>	1500 (L)	Screw-nut	— —	—	1	18.620
1000	—	—	18 <sup>ⓑ</sup>	1500 (L)	Screw-nut	— —	—	1	21.400

- Ⓐ G495 mechanical latch cannot be mounted.
- Ⓑ Maximum voltage is limited at 300V for UL. For certified type up to 600V, consult Technical support for information; see contact details on inside front cover.
- Ⓒ Highly conductive auxiliary contact.
- Ⓓ For use at this other current value, a 16mm<sup>2</sup> cable, headed with a fork terminal, must be used.
- Ⓔ No UL/CSA ratings; data given for indication and reference purposes only.
- Ⓕ Definite-purpose (DP) contactors are available. Consult Technical support for information; see contact details on inside front cover.
- Ⓖ The contactor coil is controlled electronically; it can have either an AC or a DC supply and has a wide operating range.  
Complete the order code only with the digit of the coil voltage.  
Standard voltages are:  
— AC/DC 024 = 24...60VAC/20...60VDC; 110 = 60...130VAC/DC; 230 = 100...250VAC/DC;  
400 = 250...500VAC/DC.
- Ⓖ<sup>14</sup> The values in brackets indicate the class of the fuse to be used.  
Where there is no value in brackets, any type of fuse can be used.  
For protection with motor protection circuit breaker (type F combination motor controller) see chapter 1.

### Certifications and compliance

Certifications obtained:

Type	cULus	UL	CSA	EAC	CCC	RINA
BG06D	●			●	●	
BG09D	●			●	●	
BG12D	●			●	●	
BGF09D	●			●	●	
BGP09D <sup>ⓐ</sup>	● <sup>ⓐ</sup>	●	●			
BF09D - BF09L	●		●	●	●	●
BF12D - BF12L	●		● <sup>ⓑ</sup>	●	●	●
BF18D - BF18L	●		●	●	●	●
BF25D - BF25L	●		● <sup>ⓑ</sup>	●	●	●
BF26D - BF26L	●		●	●	●	●
BF32D - BF32L	●		●	●	●	●
BF38D - BF38L	●		● <sup>ⓑ</sup>	●	●	●
BF40E	●			●	●	
BF50E	●			●	●	
BF65E	● <sup>ⓑ</sup>			●	●	
BF80E	●			●	●	
BF94E	●					
BF95E	● <sup>ⓑ</sup>					
BF115E	●					
BF150E	● <sup>ⓑ</sup>					
B195E	●			Ⓖ	Ⓖ	
B160E	●			Ⓖ	Ⓖ	
B230E	●			Ⓖ	Ⓖ	
B250		●	●	●	●	●
B310		●	●	●	●	●
B400		●	●	●	●	●
B500	●			●		
B630	●			●	●	
B6301000	●			●		

● Certified products.

- UL - UL Listed, for USA and Canada (cULus File E93602) for BG...BF110 types indicated, as Motor Controllers - Contactors, except for BGP09... types which are UL Recognized, for USA and Canada (cULus File E93602 - Component). Products having this type of marking are intended for use as components of complete workshop-assembled equipment.  
BGP is UL rated up to 300V; for type with rating up to 600V, consult Technical support for information - see contact details on inside front cover.  
UL Listed for USA only (File E93602) for B250...B400 types indicated, as Motor Controllers - Contactors.  
UL Listed for USA and Canada (cULus - File E172189) for B500...B630 1000 and B500 SL... B630 SL types as Industrial Control Switches.
- CSA - BF09...BF95 and B250...B400 contactors are also CSA certified, for Canada only (File 54332).  
In addition, BF12... BF25... and BF38... types are CSA certified as "Elevator Equipment" (File 54332, class 2411); BF65 is UL certified as "Elevator Equipment" (File E 93602).  
See technical characteristics on page 2-70.

- ⓑ This contactor has also achieved elevator equipment certification.
- Ⓖ Pending.

Compliant with standards: IEC/EN/BS 60947-1, IEC/EN/BS 60947-4-1, UL508, CSA C22.2 n° 14; UL 60947-1, UL 60947-4-1, CSA C22.2 n° 60947-1, CSA C22.2 n° 60947-4-1. Plastic materials are compliant with standards IEC/EN/BS 60335; for all BF09...BF38 versions only, add suffix V260 to the standard product order code.  
Example: BF09 10 D024 V260 for BF09, three poles, with one NO contact and 24VDC coil with compliant plastic materials.





## 2 Contactors

### Four-pole contactors with AC control circuit



new



BG09T4A BF09AT4A...BF18T4A BF26T4A...BF38T4A BF40T4A...BF80T4A BF95T4A...BF150T4A BF160T4E...BF230T4E B2504...B4004

Resistive load control

Order code	IEC operating current Ith (AC1)				Maximum IEC power at ≤40°C (AC1)							UL/CSA details
	≤40°C	≤55°C	≤70°C	Ie (AC3) ≤440V at ≤55°C	230V	400V	415V	440V	500V	690V	1000V	UL/CSA General (purpose) use
AC coil	[A]	[A]	[A]	[A]	[kW]	[kW]	[kW]	[kW]	[kW]	[kW]	[kW]	[A]
11BG09T4A①②	20	18	15	9	8	14	14	15	16	22	—	20
11BGF09T4A①	20	18	15	9	8	14	14	15	16	22	—	20
11BGP09T4A①	20	18	15	9	8	14	14	15	16	—	—	20⑦
BF09T4A①②	25	20	18	9	9.5	16	17	18	21	27	—	25
BF12T4A①②	28	23	20	12	10	18	19	20	23	32	—	28
BF18T4A①②	32	26	23	18	12	21	22	23	26	36	—	32
BF26T4A①③④	45	36	32	26	17	30	31	33	37	51	—	45
BF38T4A①⑤	56 (60⑧)	45 (48⑧)	40 (42⑧)	38	21	36	38	40	45	62	—	55
BF40T4A①	70	60	50	40	26	46	48	51	58	79	115	70
BF50T4A①②	90	75	65	50	34	59	61	65	74	102	148	90
BF65T4A①②	100	80	70	65	38	65	68	72	82	114	165	100
BF80T4A①②	115	95	80	80	43	76	79	83	95	120	185	115
BF95T4A①	140	115	100	95	53	92	96	101	115	159	230	140
BF115T4A①	160	130	115	115	61	105	109	116	132	182	263	160
BF150T4A①	165	135	118	150	62	110	113	119	136	187	271	165
BF160T4E②	250	210	180	160	95	165	171	181	206	284	411	250
BF195T4E②	275	230	200	195	104	181	188	199	226	312	452	275
BF230T4E②	350	290	250	230	132	230	239	253	288	397	576	350
11B250400②③	350	300	250	265	124	214	234	255	282	380	560	350
11B310400②③	450	370	300	320	158	270	293	325	350	488	700	450
11B400400②③	550	430	360	420	200	345	377	400	452	598	870	550
11B500400②③	700	550	500	520	252	438	478	500	575	755	1100	700
11B630400②③	800	640	540	630	288	500	545	580	655	860	1250	800
11B6301000400②③	1000	850	700	—	350	600	630	725	750	1000	1600	1000
11B1250424⑥⑥	1250	1050	880	—	480	830	900	905	1100	1450	2000	No UL/CSA
11B1600424⑥⑥	1600	1360	1120	—	550	950	1000	1160	1200	1650	2500	No UL/CSA

① Complete order code with coil voltage digit or voltage digit followed by 60 if 60Hz.

Standard voltages are as follows:

- AC 50/60Hz 024 / 048 / 110 / 230 / 400V

- AC 60Hz 024 60 / 048 60 / 120 60 / 220 60 / 230 60 / 460 60 / 575 60 (V).

Example: 11BG09T4A230 for mini-contactor BG09, four poles, with 230VAC 50/60Hz coil. 11BG09T4A460 60 for mini-contactor BG09, four poles, with 460VAC 60Hz coil.

② The coil of the contactor can be powered indifferently in AC or DC. Complete the order code only with the digit of the coil voltage. Standard voltages are:

- AC/DC 24 / 48 / 60 / 110-125 (indicate 110) / 220-240 (indicate 220) / 380-415 (indicate 380) / 440-480V (indicate 440).

Example: 11B250400110 for contactor B250, four poles, without auxiliary contacts and with 110-125VAC/DC coil.

The 24VAC/DC voltage is not possible for B500...B6301000 contactors.

Other voltages available on request.

③ If predisposed for mechanical latch (G495), the order code becomes 11B...4SL00 ②.

If already fitted with mechanical latch (G495), the order code becomes 11B...4L00 ② ④.

④ Indicate rated voltage of the mechanical latch, preceded by the letter C if in DC.

Standard voltages are:

- AC 50/60Hz 48 / 110-125 indicate 110 / 220-240 indicate 220 / 380-415V indicate 380

- DC 48 / 110-125 indicate 110 / 220-240V indicate 220.

Example: 11B2504L00110C220 for contactor B250, four poles, without auxiliary contacts, with 110-125VAC/DC coil and mechanical latch powered at 220-240VDC.

⑤ G495 mechanical latch cannot be mounted.

⑥ Complete the order code with the digit of the coil voltage. For 110-125VAC 50/60Hz indicate 110 or 220-240VAC 50/60Hz indicate 220.

Example: 11B1250424110 for contactor B1250, four poles, with 2NO+4NC auxiliary contacts and 110-125VAC/DC 50/60Hz coil.

⑦ Maximum voltage is limited at 300V for UL. For certified type up to 600V. Consult Technical support for information; see contact details on inside front cover.

⑧ Whenever the BF26T4 or BF38T4 types need to be mechanically interlocked with either the BFX5000 or BFX5001, the add-on fourth pole of one of the contactors needs to be removed from the right side and fitted on the left side.

⑨ For use at this other current value, a 16mm<sup>2</sup> cable, headed with a fork terminal, must be used.

⑩ Definite-purpose (DP) contactors are available. Consult Technical support for information; see contact details on inside front cover.



# 2 Contactors

Four-pole contactors with AC control circuit

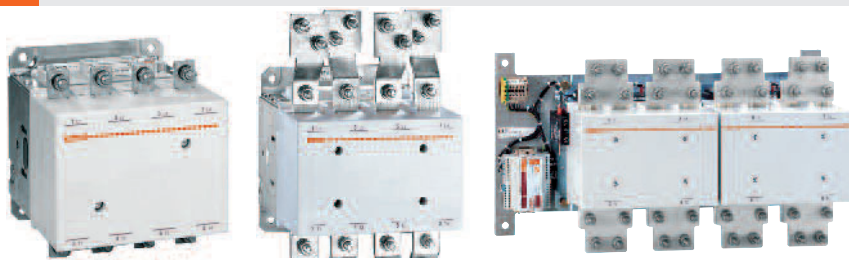

B5004-B6304

B63010004

B1250-B16004

UL/CSA Short-circuit protection fuse, 600V <sup>Ⓢ</sup>				Type of terminal	Incorporated auxiliary contacts		Qty per pkg n°	Weight [kg]
High fault Short circuit current [kA]	Fuse [A]	Standard fault Short circuit current [kA]	Fuse [A]		NO	NC		
100	30 (J)	5	30	Clamp-screw	—	—	10	0.180
100	30 (J)	5	30	Faston	—	—	10	0.180
100	30 (J)	5	30	Rear PCB solder pin	—	—	10	0.197
100	30 (J)	5	60	Clamp-screw	—	—	1	0.367
100	30 (J)	5	70	Clamp-screw	—	—	1	0.367
100	60 (J)	5	80	Clamp-screw	—	—	1	0.367
100	100 (J)	5	100	Clamp-screw	—	—	1	0.508
100	100 (J)	5	150	Clamp-screw	—	—	1	0.508
100	150 (J)	5	150 (RK5)	Double lug-clamp	—	—	1	1.240
100	150 (J)	5	150 (RK5)	Double lug-clamp	—	—	1	1.240
100	200 (J)	10	200 (RK5)	Double lug-clamp	—	—	1	1.240
100	200 (J)	10	200 (RK5)	Double lug-clamp	—	—	1	1.240
100	200 (J)	10	250 (RK5)	Double lug-clamp	—	—	1	2.420
100	200 (J)	10	250 (RK5)	Double lug-clamp	—	—	1	2.420
100	200 (J)	10	250 (RK5)	Double lug-clamp	—	—	1	2.420
100	400 (J)	10	400 (RK5)	Screw-nut	—	—	1	4.000
100	400 (J)	10	400 (RK5)	Screw-nut	—	—	1	4.000
100	400 (J)	10	400 (RK5)	Screw-nut	—	—	1	4.000
—	—	18	800 (L)	Screw-nut	—	—	1	11.195
—	—	18	800 (L)	Screw-nut	—	—	1	11.195
—	—	18	800 (L)	Screw-nut	—	—	1	11.195
—	—	18 <sup>Ⓢ</sup>	1200 (L)	Screw-nut	—	—	1	20.910
—	—	18 <sup>Ⓢ</sup>	1500 (L)	Screw-nut	—	—	1	21.880
—	—	18 <sup>Ⓢ</sup>	1500 (L)	Screw-nut	—	—	1	25.620
—	—	—	—	Screw-nut	2	4	1	57.500
—	—	—	—	Screw-nut	2	4	1	58.400

- Ⓢ IEC/EN/BS 60947-1 designation: Pillar terminal.
- Ⓢ The contactor coil is controlled electronically; it can have either an AC or a DC supply and has a wide operating range. Complete the order code only with the digit of the coil voltage.  
Standard voltages are:  
- AC/DC 024 = 24...60VAC/20...60VDC; 110 = 60...130VAC/DC; 230 = 100...250VAC/DC;  
400 = 250...500VAC/DC.
- Ⓢ The values in brackets indicate the class of the fuse to be used.  
Where there is no value in brackets, any type of fuse can be used.  
For protection with motor protection circuit breaker (type F combination motor controller) see chapter 1.

### IEC utilisation current with poles in parallel

If the poles of the contactors are arranged in parallel, the operating current is the one indicated in the table multiplied by the **K** factor given below, which account for the unequal distribution of the current in the various poles.  
To limit distribution inequality, it is advisable to use paralleling links (see pages 2-18, 2-23, 2-28 and 2-30).

- 2 POLES in parallel: **K = 1.6**
- 3 POLES in parallel: **K = 2.2**
- 4 POLES in parallel: **K = 2.8**

### Certifications and compliance

Certifications obtained:

Type	CULus	UL	CSA	EAC	CCC	RINA
BG09T4A	●			●	●	
BGF09T4A	●			●	●	
BGP09T4A <sup>Ⓢ</sup>	● <sup>Ⓢ</sup>			●	●	
BF09T4A	●		●	●	●	●
BF12T4A	●		● <sup>Ⓢ</sup>	●	●	●
BF18T4A	●		●	●	●	●
BF26T4A	●		● <sup>Ⓢ</sup>	●	●	●
BF38T4A	●		● <sup>Ⓢ</sup>	●	●	●
BF40T4A	●			●	●	●
BF50T4A	●			●	●	●
BF65T4A	● <sup>Ⓢ</sup>			●	●	●
BF80T4A	●			●	●	●
BF95T4A	● <sup>Ⓢ</sup>					●
BF115T4A	●					●
BF150T4A	● <sup>Ⓢ</sup>					●
BF160T4E	●			● <sup>Ⓢ</sup>	● <sup>Ⓢ</sup>	
BF195T4E	●			● <sup>Ⓢ</sup>	● <sup>Ⓢ</sup>	
BF230T4E	●			● <sup>Ⓢ</sup>	● <sup>Ⓢ</sup>	
B2504		●	●	●	●	
B3104		●	●	●	●	
B4004		●	●	●	●	
B5004	●			●		
B6304	●			●	●	
B63010004	●			●		
B12504				●		
B16004				●		

● Certified products.

- UL - UL Listed, for USA and Canada (cULus File E93602) for BG...BF150 types indicated, as Motor Controllers – Contactors, except for BGP09... types which are UL Recognized, for USA and Canada (cULus File E93602 – Component). Products having this type of marking are intended for use as components of complete workshop-assembled equipment.  
BGP is UL rated up to 300V; for type with rating up to 600V, consult Technical support for information – see contact details on inside front cover.  
UL Listed for USA only (File E93602) for B250...B400 types indicated, as Motor Controllers – Contactors.  
UL Listed for USA and Canada (cULus - File E172189) for B5004... B63010004 and B5004SL... B6304SL types as Industrial Control Switches.
- CSA - BF09...BF80 and B250...B400 contactors are also CSA certified, for Canada only (File 54332).  
In addition, BF12... BF25... BF38... and BF65... types are CSA certified as "Elevator Equipment" (File 54332, class 2411).  
See technical characteristics on page 2-70.

- Ⓢ This contactor has also achieved elevator equipment certification.
- Ⓢ Pending.

Compliant with standards: IEC/EN/BS 60947-1, IEC/EN/BS 60947-4-1, UL508, CSA C22.2 n° 14; UL 60947-1, UL 60947-4-1, CSA C22.2 n° 60947-1, CSA C22.2 n° 60947-4-1. Plastic materials are compliant with standards IEC/EN/BS 60335; for all BF09...BF38 versions only, add suffix V260 to the standard product order code.  
Example: BF09T4A230V260 for BF09, four poles, 230V 50/60Hz coil with compliant plastic materials.



## 2 Contactors

Four-pole contactors with DC and AC/DC control circuit

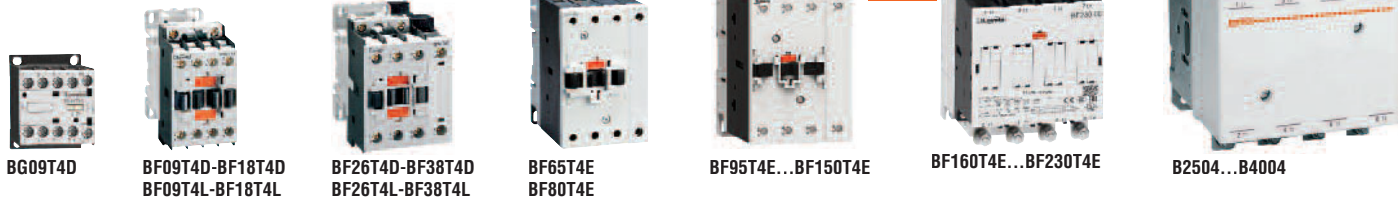

Resistive load control												UL/CSA details	
Order code DC coil	DC coil Low consumption	IEC operating current I <sub>th</sub> (AC1)			I <sub>e</sub> (AC3) ≤440V at ≤55°C	Maximum IEC power at ≤40°C (AC1)							UL/CSA General (purpose) use
		≤40°C	≤55°C	≤70°C		230V	400V	415V	440V	500V	690V	1000V	
		[A]	[A]	[A]	[A]	[kW]	[kW]	[kW]	[kW]	[kW]	[kW]	[kW]	[A]
11BG09T4D①	—	20	18	15	9	8	14	14	15	16	22	—	20
11BGF09T4D①	—	20	18	15	9	8	14	14	15	16	22	—	20
11BGP09T4D①	—	20	18	15	9	8	14	14	15	16	—	—	20⑥
BF09T4D①	BF09T4L②	25	20	18	9	9.5	16	17	18	21	27	—	25
BF18T4D①	BF18T4L②	32	26	23	18	12	21	22	23	26	36	—	32
BF26T4D①	BF26T4L②	45	36	32	26	17	30	31	33	37	51	—	45
BF38T4D①	BF38T4L②	56 (60⑦)	45 (48⑦)	40 (42⑦)	38	21	26	38	40	45	62	—	55
BF65T4E⑧	—	100	80	70	65	38	65	68	72	82	114	165	100
BF80T4E⑧	—	115	95	80	80	43	76	79	83	95	120	185	115
BF95T4E⑧	—	140	115	100	95	53	92	96	101	115	159	230	140
BF150T4E⑧	—	165	135	118	150	62	110	113	119	136	187	271	165
BF160T4E ⑩	—	250	210	180	160	95	165	171	181	206	284	411	250
BF195T4E ⑩	—	275	230	200	195	104	181	188	199	226	312	452	275
BF230T4E ⑩	—	350	290	250	230	132	230	239	253	288	397	576	350
11B250400④⑤	—	350	300	250	265	124	214	234	255	282	380	560	350
11B310400④⑦	—	450	370	300	320	158	270	293	325	350	488	700	450
11B400400④⑤	—	550	430	360	420	200	345	377	400	452	598	870	550
11B500400④⑤	—	700	550	500	520	252	438	478	500	575	755	1100	700
11B630400④⑤	—	800	640	540	630	288	500	545	580	655	860	1250	800
11B6301000400④⑥	—	1000	850	700	—	350	600	630	725	750	1000	1600	1000

- ① Complete order code with coil voltage digit.  
The BF09-BF38D types already have a standard supplied built-in TVS (Transient Voltage Suppressor).  
Standard voltages are as follows:  
– DC 012 / 024 / 048 / 060 / 110 / 125 / 220VDC.  
Example: 11BG09T4D012 for mini-contactor BG09, four poles, with 12VDC coil.
- ② Low consumption version. Complete the order code with coil voltage digit.  
The BF09-BF38L types already have a standard supplied built-in TVS (Transient Voltage Suppressor).  
Standard voltages are as follows:  
– DC 024 / 048V  
Example: BF09T4L024 for contactor BF09, four poles, with 24VDC low-consumption coil.
- ③ The contactor coil is controlled electronically; it can have either an AC or a DC supply and has a wide operating range.  
Complete the order code only with the digit of the coil voltage.  
Standard voltages are:  
– AC/DC 024 = 20...48V; 110 = 60...110V; 230 = 100...250V.
- ④ The coil of the contactor can be powered indifferently in AC or DC. Complete the order code only with the digit of the coil voltage.  
Standard voltages are:  
– AC/DC 24 / 48 / 60 / 110-125 indicate 110 / 220-240 indicate 220 / 380-415 indicate 380 / 440-480V indicate 440.  
Example: 11B25000110 for contactor B250, four poles, without auxiliary contacts and with 110-125VAC/DC coil.  
The 24VAC/DC voltage is not possible for B500-B630 1000 contactors.  
**The 24V voltage is not possible for B500...B6301000 contactors.**  
Other voltages available on request.
- ⑤ If predisposed for mechanical latch (G495), the order code becomes 11B...4SL00 ④.  
If already fitted with mechanical latch (G495), the order code becomes 11B...4L00 ④ ⑥.

- ⑥ Indicate rated voltage of the mechanical latch, preceded by the letter C if in DC.  
Standard voltages are:  
– AC 50/60Hz 48 / 110-125 indicate 110 / 220-240 indicate 220 / 380-415V indicate 380  
– DC 48 / 110-125 indicate 110 / 220-240V indicate 220.  
Example: 11B250L00110C48 for contactor B250, four poles, without auxiliary contacts, with 110-125VAC/DC coil and mechanical latch powered at 48VDC.
- ⑦ G495 mechanical latch cannot be mounted.
- ⑧ Maximum voltage is limited at 300V for UL. For certified type up to 600V consult Technical support for information; see contact details on inside front cover.
- ⑩ For use at this other current value, a 16mm<sup>2</sup> cable, headed with a fork terminal, must be used.





## 2 Contactors

Four-pole contactors with DC and AC/DC control circuit



B5004-B6304



B63010004

UL/CSA Short-circuit protection fuse, 600V <sup>Ⓢ</sup>				Type of terminal	Incorporated auxiliary contacts		Qty per pkg n°	Weight [kg]
High fault Short circuit current		Standard fault Short circuit current			NO	NC		
[kA]	Fuse [A]	[kA]	Fuse [A]					
100	30 (J)	5	30	Clamp-screw	—	—	10	0.220
100	30 (J)	5	30	Faston	—	—	10	0.220
100	30 (J)	5	30	Rear PCB solder pin	—	—	10	0.242
100	30 (J)	5	60	Clamp-screw	—	—	1	0.498
100	60 (J)	5	80	Clamp-screw	—	—	1	0.498
100	100 (J)	5	100	Clamp-screw	—	—	1	0.665
100	100 (J)	5	150	Clamp-screw	—	—	1	0.665
100	200 (J)	10	200 (RK5)	Double lug-clamp	—	—	1	1.280
100	200 (J)	10	200 (RK5)	Double lug-clamp	—	—	1	1.280
100	200 (J)	10	250 (RK5)	Double lug-clamp	—	—	1	2.460
100	200 (J)	10	250 (RK5)	Double lug-clamp	—	—	1	2.460
100	400 (J)	10	400 (RK5)	Screw-nut	—	—	1	4.000
100	400 (J)	10	400 (RK5)	Screw-nut	—	—	1	4.000
100	400 (J)	10	400 (RK5)	Screw-nut	—	—	1	4.000
—	—	18	800 (L)	Screw-nut	—	—	1	11.195
—	—	18	800 (L)	Screw-nut	—	—	1	11.195
—	—	18	800 (L)	Screw-nut	—	—	1	11.195
—	—	18 <sup>Ⓢ</sup>	1200 (L)	Screw-nut	—	—	1	20.910
—	—	18 <sup>Ⓢ</sup>	1500 (L)	Screw-nut	—	—	1	21.880
—	—	18 <sup>Ⓢ</sup>	1500 (L)	Screw-nut	—	—	1	25.600

- Ⓢ No UL/CSA ratings; data given for indication and reference purposes only.
- Ⓢ The contactor coil is controlled electronically; it can have either an AC or a DC supply and has a wide operating range.  
Complete the order code only with the digit of the coil voltage.  
Standard voltages are:  
– AC/DC 024 = 24...60VAC/20...60VDC; 110 = 60...130VAC/DC; 230 = 100...250VAC/DC;  
400 = 250...500VAC/DC.
- Ⓢ The values in brackets indicate the class of the fuse to be used.  
Where there is no value in brackets, any type of fuse can be used.  
For protection with motor protection circuit breaker (type F combination motor controller) see chapter 1.

### IEC utilisation current with poles in parallel

If the poles of the contactors are arranged in parallel, the operating current is the one indicated in the table multiplied by the **K** factor given below, which account for the unequal distribution of the current in the various poles.  
To limit distribution inequality, it is advisable to use paralleling links (see pages 2-18, 2-23, 2-28 and 2-30).

- 2 POLES in parallel: **K** = 1.6
- 3 POLES in parallel: **K** = 2.2
- 4 POLES in parallel: **K** = 2.8

### Certifications and compliance

Certifications obtained:

Type	cULus	UL	CSA	EAC	CCC	RINA
BG09T4D	●			●	●	
BGF09T4D	●			●	●	
BGP09T4D <sup>Ⓢ</sup>	●			●	●	
BF09T4D - BF09T4L	●		●	●	●	●
BF18T4D - BF18T4L	●		●	●	●	●
BF26T4D - BF26T4L	●		● <sup>Ⓢ</sup>	●	●	●
BF38T4D - BF38T4L	●		● <sup>Ⓢ</sup>	●	●	●
BF65T4E	● <sup>Ⓢ</sup>			●	●	
BF80T4E	●			●	●	
BF95T4E	● <sup>Ⓢ</sup>					
BF150T4E	● <sup>Ⓢ</sup>					
BF160T4E	●			● <sup>Ⓢ</sup>	● <sup>Ⓢ</sup>	
BF195T4E	●			● <sup>Ⓢ</sup>	● <sup>Ⓢ</sup>	
BF230T4E	●			● <sup>Ⓢ</sup>	● <sup>Ⓢ</sup>	
B2504		●	●	●	●	
B3104		●	●	●	●	
B4004		●	●	●	●	
B5004	●			●		
B6304	●			●	●	
B63010004	●			●		

● Certified products.

- UL - UL Listed, for USA and Canada (cULus File E93602) for BG...BF150 types indicated, as Motor Controllers – Contactors, except for BGP09... types which are UL Recognized, for USA and Canada (●<sup>Ⓢ</sup>, File E93602 – Component). Products having this type of marking are intended for use as components of complete workshop-assembled equipment.  
BGP is UL rated up to 300V; for type with rating up to 600V, consult Technical support for information – see contact details on inside front cover.  
UL Listed for USA only (File E93602) for B250...B400 types indicated, as Motor Controllers – Contactors.  
UL Listed for USA and Canada (cULus - File E172185) for B5004... B63010004 and B5004SL... B6304SL types as Industrial Control Switches.
- CSA - BF09...BF95 and B250...B400 contactors are also CSA certified, for Canada only (File 54332).  
In addition, BF12..., BF25..., BF38... and BF65... types are CSA certified as "Elevator Equipment" (File 54332, class 2411).  
See technical characteristics on page 2-70.

- Ⓢ This contactor has also achieved elevator equipment certification.
- Ⓢ Pending.

Compliant with standards: IEC/EN/BS 60947-1, IEC/EN/BS 60947-4-1, UL508, CSA C22.2 n° 14; UL 60947-1, UL 60947-4-1, CSA C22.2 n° 60947-1, CSA C22.2 n° 60947-4-1. Plastic materials are compliant with standards IEC/EN/BS 60335; for all BF09...BF38 versions only, add suffix V260 to the standard product order code.  
Example: BF09T4D024V260 for BF09, four poles, 24VDC coil with compliant plastic materials.



## 2 Contactors

Four-pole contactors with control circuit: AC and DC

### Mini-contactor four power poles, 2 NO and 2 NC BG series



11BG09T2...

Order code	IEC rated conventional free air thermal current Ith			Qty per pkg	Wt [kg]
	≤40°C	≤55°C	≤60°C		
	[A]	[A]	[A]	n°	[kg]
AC COIL. Terminals: clamp screw.					
<b>11BG09T2A</b>	20	18	15	1	0.170
DC COIL. Terminals: clamp screw.					
<b>11BG09T2D</b>	20	18	15	1	0.175

### Contactors four power poles, 2 NO and 2 NC BF series

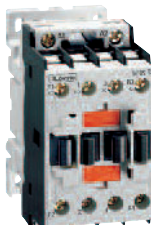

BF09T2...

Order code	IEC rated conventional free air thermal current Ith			Qty per pkg	Wt [kg]
	≤40°C	≤55°C	≤60°C		
	[A]	[A]	[A]	n°	[kg]
AC COIL. Terminals: clamp screw.					
<b>BF09T2A</b>	25	20	18	1	0.340
<b>BF18T2A</b>	32	26	23	1	0.340
<b>BF26T2A</b>	45	36	32	1	0.420
<b>BF38T2A</b>	56 (60)	45 (48)	40 (42)	1	0.420
<b>BF80T2A</b>	115	95	75	1	1.075
DC COIL. Terminals: clamp screw.					
<b>BF18T2D</b>	32	26	23	1	0.470
<b>BF26T2D</b>	45	36	32	1	0.540
<b>BF38T2D</b>	56 (60)	45 (48)	40 (42)	1	0.540
<b>BF80T2E</b>	115	95	75	1	1.125
DC COIL. Low consumption (2.4W). Terminals: clamp screw.					
<b>BF18T2L</b>	32	26	23	1	0.470
<b>BF26T2L</b>	45	36	32	1	0.540
<b>BF38T2L</b>	56 (60)	45 (48)	40 (42)	1	0.540

### Contactors four power poles, 4 NC BF series



BF18T0...

Order code	IEC rated conventional free air thermal current Ith			Qty per pkg	Wt [kg]
	≤40°C	≤55°C	≤60°C		
	[A]	[A]	[A]	n°	[kg]
AC COIL. Terminals: clamp screw.					
<b>BF18T0A</b>	32	26	23	1	0.340
<b>BF26T0A</b>	45	36	32	1	0.420
DC COIL. Terminals: clamp screw.					
<b>BF18T0D</b>	32	26	23	1	0.470
<b>BF26T0D</b>	45	36	32	1	0.540
DC COIL. Low consumption (2.4W). Terminals: clamp screw.					
<b>BF18T0L</b>	32	26	23	1	0.470

- 1 Complete with coil voltage digit if 50/60Hz or with voltage digit followed by 60 if 60Hz. N.B.: For BF80T2, 50/60Hz coils are suitable for 50Hz only.  
Standard voltages are:  
- AC 50/60Hz 024 / 048 / 110 / 230 / 400V  
- AC 60Hz 024 60 / 048 60 / 120 60 / 220 60 / 230 60 / 460 60 / 575 60 (V).

- 2 Complete the order code with coil voltage digit.  
Standard voltages are:  
- DC 012 / 024 / 048 / 060 / 110 / 125 / 220V.  
The BF18-BF26-BF38 T2D types already have a standard supplied built-in TVS (Transient Voltage Suppressor).  
Example:  
- 11 BG09T2D012 for mini-contactor BG09T2, 2 poles NO and 2 poles NC, with 12VDC coil.

- 3 Low consumption version with built-in TVS. Complete the order code with coil voltage digit.  
Standard voltages are:  
- DC 024 / 048V.  
Example:  
- BF18T2L024 for contactor BF18T2, 2 poles NO and 2 poles NC, with 24VDC low-consumption coil, supplied with TVS.
- 4 The contactor coil is controlled electronically; it can have either an AC or a DC supply and has a wide operating range. Complete the order code with coil voltage digit.  
Standard voltages are:  
- AC/DC 024 = 20...48V; 110 = 60...110V; 230 = 100...250V.
- 5 For use at this other current value, a 16mm<sup>2</sup> cable, headed with a fork terminal, must be used.
- 6 Maximum combinations of add-on blocks are given on page 2-19.
- 7 For BF80T2E... contactors, coil supply voltage must be AC or smoothed DC. For pulsating DC please consult our Technical support.

### Operational characteristics

Type	UL/CSA	Protection fuse		Conductor section	
	General use	IEC gG	UL K5	[mm <sup>2</sup> ]	[AWG]
	[A]	[A]	[A]	[mm <sup>2</sup> ]	[AWG]
BG09...T2	20	20	30	0.75-2.5	18-12

### Certifications and compliance

Certifications obtained: CCC, EAC; UL Listed, for USA and Canada (cULus - File E93602), as Motor Controllers - Contactors. Compliant with standards: IEC/EN/BS 60947-1, IEC/EN/BS 60947-4-1, UL 60947-4-1, CSA C22.2 n° 60947-1, CSA C22.2 n° 60947-4-1.

### Operational characteristics

Type	UL/CSA	Protection fuse		Conductor section	
	General use	IEC gG	UL RK5	[mm <sup>2</sup> ]	[AWG]
	[A]	[A]	[A]	[mm <sup>2</sup> ]	[AWG]

BF09T2	25	32	60	1-6	16-10
BF18T2	32	40	80	1-6	16-10
BF26T2	45	50	100	1.5-10	14-6
BF38T2	55	80	150	2.5-16	14-6
BF80T2	115	115	250	6-50	18-2

### Certifications and compliance

Certifications obtained: EAC, CCC, RINA; UL Listed for USA and Canada (cULus - File E93602) and CSA certified for Canada (File 54332), as Motor Controllers - Contactors. Compliant with standards: IEC/EN/BS 60947-1, IEC/EN/BS 60947-4-1, UL 60947-4-1, CSA C22.2 n° 60947-1, CSA C22.2 n° 60947-4-1. Plastic materials are compliant with standards IEC/EN/BS 60335; for all BF09...BF38 versions only, add suffix V260 to the standard product order code. Example: BF09T2A230 V260 for BF09, 2NO+2NC main poles, 230V 50/60Hz coil with compliant plastic materials).

### Operational characteristics

Type	UL/CSA	Protection fuse		Conductor section	
	General use	IEC gG	UL RK5	[mm <sup>2</sup> ]	[AWG]
	[A]	[A]	[A]	[mm <sup>2</sup> ]	[AWG]

BF18T0	32	40	80	1-6	16-10
BF26T0	45	50	150	1.5-10	14-6

### Certifications and compliance

Certifications obtained: EAC, CCC, RINA; UL Listed for USA and Canada (cULus - File E93602) and CSA certified for Canada (File 54332), as Motor Controllers - Contactors. Compliant with standards: IEC/EN/BS 60947-1, IEC/EN/BS 60947-4-1, UL 60947-4-1, CSA C22.2 n° 60947-1, CSA C22.2 n° 60947-4-1. Plastic materials are compliant with standards IEC/EN/BS 60335; for BF18 and BF26 versions only, add suffix V260 to the standard product order code. Example: BF18T0A230V260 for BF18, four NC main poles, 230VAC 50/60Hz coil with compliant plastic materials).

NOTE: The BF18-BF26T0D and BF18T0L types have a standard supplied built-in TVS (Transient Voltage Suppressor).

## 2 Contactors

Contactors for photovoltaic applications with control circuit AC and AC/DC

### 3 pole contactors to connect in series for photovoltaic applications BF series



BFD6500A - BFD8000A

**new**

Order code	Operational current at 600V in DC1 ≤55°C with 3 poles in series		Qty per pkg	Wt [kg]
	600V [A]	1000V [A]		
BFD6500A	75	35	1	1,020
BFD8000A	80	60	1	1,020

AC COIL.  
Terminals: double lug clamp.

Order code	Operational current at 600V in DC1 ≤55°C with 4 poles in series	Qty per pkg	Wt [kg]
BFD80T4A	100	1	1.100
BFD80T4E	80	1	1.100
BFD150T4E	165	1	2.550
BFD230T4E	350	1	4.000

### 4 pole contactors to connect in series for photovoltaic applications BF series



BFD80T4...

**new**

Order code	Operational current at 600V in DC1 ≤55°C with 4 poles in series		Qty per pkg	Wt [kg]
	600V [A]	1000V [A]		
BFD80T4A	100	80	1	1.100
BFD80T4E	100	80	1	1.100
BFD150T4E	165	100	1	2.550
BFD230T4E	350	275	1	4.000

AC COIL.  
Terminals: double lug-clamp.

AC/DC COIL.  
Terminals: double lug-clamp (screw-nut for BFD230T4E).

Order code	Operational current at 600V in DC1 ≤55°C with 4 poles in series	Qty per pkg	Wt [kg]
BFD80T4A	100	1	1.100
BFD80T4E	80	1	1.100
BFD150T4E	165	1	2.550
BFD230T4E	350	1	4.000

- ① Complete with coil voltage digit if 50/60Hz or with voltage digit followed by 60 if 60Hz. Standard voltages are:  
 - AC 50/60Hz 024 / 048 / 110 / 230 / 400V  
 - AC 60Hz 024 60 / 048 60 / 120 60 / 220 60 / 230 60 / 460 60 / 575 60 (V).
- ② The contactor coil is controlled electronically; it can have either an AC or a DC supply and has a wide operating range.  
 Complete the order code with coil voltage digit.  
 Standard voltages are:  
 - AC/DC 024 = 20...48V; 110 = 60...110V; 230 = 100...250V.
- ③ The contactor coil is controlled electronically; it can have either an AC or a DC supply and has a wide operating range.  
 Complete the order code only with the digit of the coil voltage.  
 Standard voltages are:  
 - AC/DC 024 = 24...60VAC/20...60VDC; 110 = 60...130VAC/DC; 230 = 100...250VAC/DC; 400 = 250...500VAC/DC.



BFD150T4E



BFD230T4E...

### General characteristics

The contactors are specifically made with magnetic elements in the arc extinction chambers to obtain high DC load operational capabilities. They are used to disconnect and isolate the load between the photovoltaic panel and the AC/DC inverter.

For add-on contact blocks, accessories and spare parts, consider indications of the corresponding standard contactors without the D letter in the code.

### Italian Fire Department Directives

These directives provide for a disconnecting device for all current-carrying elements, that can be operated by remote control switch, placed in an easily reached and marked position, in order to safely isolate each part of the installation within the fire system compartment including the photovoltaic (PV) generator.

As an alternative, the PV generator must be installed, either externally of the fire system compartment or internally but in a dedicated compartment with adequate fire-resistant features. For such function, specifically designed contactors for on-load use in IEC DC1 duty up to 1000VDC are available.

### Operational characteristics

Use in IEC DC1 duty

Type	Poles in series	IEC operational voltage Ue			
		400V	600V	800V	1000V
		IEC max current Ie in DC1 with L/R ≤1ms with 4 poles in series			
BFD6500A...	3	100	75	45	35
BFD8000A...	3	100	80	65	60
BFD80T4A...	4	115	100	90	80
BFD80T4E...	4	115	100	90	80
BFD150T4E...	4	165	165	125	100
BFD230T4E...	4	350	350	300	275

### Certification and compliance

Compliant with standards: IEC/EN/BS 60947-1, IEC/EN/BS 60947-4-1, UL 60947-4-1, CSA C22.2 n° 60947-1, CSA C22.2 n° 60947-4-1.





## 2 Contactors

Contactors for power factor correction with AC control circuit

### BFK contactors (including limiting resistors)

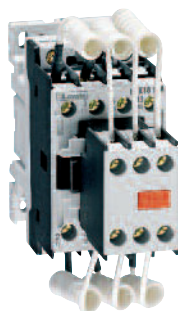

BFK...

**new**

Order code	Maximum IEC operational power at ≤50°C (AC-6b) ①				NO	n°	Wt [kg]
	240V	400V	440V	690V			
	[kvar]	[kvar]	[kvar]	[kvar]			
AC COIL							
<b>BFK0910A</b> ②	4.5	7.5	9	10	1	10	0.413
<b>BFK1210A</b> ②	7	12.5	14	16	1	10	0.413
<b>BFK1810A</b> ②	9	15	17	20	1	10	0.413
<b>BFK2600A</b> ②	11	20	22	25	-	10	0.472
<b>BFK3200A</b> ②	14	25	27.5	30	-	10	0.472
<b>BFK3800A</b> ②	17	30	33	36	-	10	0.472
<b>BFK5000A</b> ②	22	40	41	46	-	5	1.080
<b>BFK6500A</b> ②	26	45	50	56	-	5	1.080
<b>BFK8000A</b> ②	30	50	56	65	-	5	1.080
<b>BFK9400A</b> ②④	34	60	75	80	-	5	1.080
<b>BFK9500A</b> ②	34	60	75	80	-	5	2.095
<b>BFK11500A</b> ②	45	75	85	135	-	5	2.095
<b>BFK15000A</b> ②	50	100	115	150	-	5	2.095

- ① To use the contactor in the delta, consult our Technical support, see contact details on inside front cover.
- ② NO auxiliary contacts available.
- ③ The order code must be completed either with the coil voltage digit if 50/60Hz or with the coil voltage digit followed by the number 60 if 60Hz. Standard voltages are:  
 - AC 50-60Hz 024 / 048 / 110 / 230 / 400VAC  
 - AC 60Hz 024 60 / 048 60 / 120 60 / 220 60 / 230 60 / 460 60 / 575 60 (V).  
 Example: BFK0910A230 for contactor BFK09 with one NO contact and 230VAC 50/60Hz coil.  
 BFK0910A46060 for contactor BFK09 with one NO contact and 460VAC 60Hz coil.
- ④ **NOTE: the maximum thermal current Ith of the BFK94 contactor is 115A.**

UL/CSA details  
Maximum UL/CSA kvar ratings

	240V	480V	600V
	kVAR	kVAR	kVAR
BFK0910A	4.5	9	10
BFK1210A	7	14	16
BFK1810A	9	17	20
BFK2600A	11	22	27.5
BFK3200A	14	27.5	32
BFK3800A	17	33	36
BFK5000A	22	41	46
BFK6500A	26	50	56
BFK8000A	30	60	75
BFK9500A	40	80	100
BFK11500A	45	90	120
BFK15000A	50	100	125

### Kit to assemble BFK contactors



11G46...

Order code	For contactor	Qty per pkg	Wt
		n°	[kg]
<b>11G460</b>	BF0910A - BF1210A - BF1810A - BF2600A - BF3200A - BF3800A	1	0.072
<b>BFX10K3</b>	BF5000A - BF6500A - BF8000A - BF9400A	1	0.078
<b>BFX10K4</b>	BFK9500A - BF11500A - BF15000A	1	0.080

### Operational characteristics

Type	IEC rated operational current ≤440V [A]	IEC - UL/CSA protection fuse gG-SC [A]
BFK09	12	16
BFK12	18	25
BFK18	23	40
BFK26	30	40
BFK32	36	63
BFK38	43	63
BFK50	58	80
BFK65	65	100
BFK80	75	125
BFK94	90	125
BFK95	90	125
BFK115	115	160
BFK150	144	160

Ambient operating temperature: ≤50°C. For ambient temperatures higher than 50°C and up to 70°C, the maximum operating power values indicated in the table must be reduced by a percentage equal to the difference between the operating ambient temperature and 50°C.  
 E.g.: using a BFK2600 contactor at the ambient temperature of 60°C, the maximum operating power (at 400V) of the contactor will be equal to 20kvar - 10% = 18kvar.  
 Operating cycle: ≤120 cycles/h  
 Electrical life: ≥400,000 cycles.

### Add-on auxiliary contacts

The following contact blocks, can be fitted on the BFK contactors: BFX12..., 11G418..., 11G481..., 11G482... and 11G218.

### Certifications and compliance

Certification obtained (BFK9400A excluded): UL Listed for USA and Canada (cULus - File E93602), as Motor Controllers - Magnetic Capacitive Switches; CCC, EAC.  
 Compliant with standards: IEC/EN/BS 60947-1, IEC/EN/BS 60947-4-1, UL508, CSA C22.2 n° 14.  
 Plastic materials are compliant with standards IEC/EN/BS 60335; for BFK versions only, add suffix V260 to the standard product order code.

### General characteristics

To optimise contactor stock management, a kit is available to transform normal three-pole contactors into BFK types for power factor correction. The table to the left indicates which kits to purchase depending on the standard contactor in stock.

## 2 Contactors

Control relays with control circuit: AC and DC

### Control relays BG00 type



11BG00...



11BG00...

### Control relays BF00 type



BF00...A...



BF00...D...  
BF00...L...

Order code	Configuration and n° of contacts ⑤		Quantity per pkg. n°	Wt [kg]
	NO	NC		

AC COIL.  
Terminals: clamp screw.

11BG0040A①	4	0	1	0.170
11BG0031A①	3	1	1	0.170
11BG0022A①	2	2	1	0.170

Terminals: Faston.

11BGF0040A①	4	0	1	0.160
11BGF0031A①	3	1	1	0.160
11BGF0022A①	2	2	1	0.160

DC COIL.  
Terminals: clamp screw.

11BG0040D②	4	0	1	0.175
11BG0031D②	3	1	1	0.175
11BG0022D②	2	2	1	0.175

Terminals: Faston.

11BGF0040D②	4	0	1	0.165
11BGF0031D②	3	1	1	0.165
11BGF0022D②	2	2	1	0.165

DC COIL. Low-consumption (2.3W).  
Terminals: clamp screw.

11BG0040L③	4	0	1	0.175
11BG0031L③	3	1	1	0.175
11BG0022L③	2	2	1	0.175

Terminals: Faston.

11BGF0040L③	4	0	1	0.165
11BGF0031L③	3	1	1	0.165
11BGF0022L③	2	2	1	0.165

Order code	Configuration and n° of contacts ⑤		Quantity per pkg. n°	Wt [kg]
	NO	NC		

AC COIL.  
Terminals: clamp screw.

BF0040A①	4	0	1	0.340
BF0031A①	3	1	1	0.340
BF0022A①	2	2	1	0.340
BF0004A①	0	4	1	0.340

DC COIL.  
Terminals: clamp screw.

BF0040D②④	4	0	1	0.470
BF0031D②④	3	1	1	0.470
BF0022D②④	2	2	1	0.470
BF0004D②④	0	4	1	0.470

DC COIL. Low consumption (2.4W).  
Terminals: clamp screw.

BF0040L③④	4	0	1	0.470
BF0031L③④	3	1	1	0.470
BF0022L③④	2	2	1	0.470
BF0004L③④	0	4	1	0.470

- ① The order code must be completed either with the coil voltage digit if 50/60Hz or with the coil voltage digit followed by the number 60 if 60Hz. Standard voltages are:
  - AC 50/60Hz 024 / 048 / 110 - 230 / 400V
  - AC 60Hz 024 60 / 048 60 / 120 60 / 220 60 / 230 60 / 460 60 / 575 60 (V).
 Example: 11BG0040A230 (auxiliary mini-contactor 4 NO auxiliary contacts supplied at 230VAC 50/60Hz). BF0040A46060 (auxiliary contactor with 4 NO auxiliary contacts supplied at 460VAC 60Hz).
- ② Complete the order code with coil voltage digit. Standard voltages are:
  - DC 012 / 024 / 048 / 060 / 110 / 125 / 220V.
 Example: BF0040D012 (auxiliary contactor with 4 NO auxiliary contacts supplied at 12VDC).
- ③ Low-consumption version. Complete the order code with coil voltage digit. Standard voltages are:
  - DC 024 / 048V.
 Example: 11BG0040L024 (low-consumption auxiliary mini-contactor with 4 NO auxiliary contacts supplied at 24VDC).
- ④ Maximum combinations of add-on blocks are given on page 2-19.
- ⑤ All contacts are highly conductive.

### Operational characteristics

- IEC rated insulation voltage  $U_i$ : 690V
- IEC rated conventional free air thermal current  $I_{th}$ : 10A
- UL/CSA and IEC/EN/BS 60947-5-1 designation:
  - BG types: A600-Q600
  - BF types: A600-P600
- Low-consumption version of BG types cannot accept additional contacts.

**NOTE: no coil change or replacement is possible.**

### Certifications and compliance

Certification obtained: CCC, EAC, UL Listed for USA and Canada (cULus - File E93602), as Motor Controllers - Auxiliary contactors for all; RINA for BF00 types. Compliant with standards: IEC/EN/BS 60947-1, IEC/EN/BS 60947-5-1, UL 60947-4-1, CSA C22.2 n° 60947-1, CSA C22.2 n° 60947-4-1. Plastic materials are compliant with standards IEC/EN/BS 60335; for BF00 version only, add suffix V260 to the standard product order code. Example: BF0040A230V260 for BF00 control relay having 4 NO auxiliary contacts and 230VAC 50/60Hz coil with compliant plastic materials.

**NOTE: the BF00...D and BF00...L types have a standard supplied built-in TVS (Transient Voltage Suppressor).**



## 2 Contactors

Add-on blocks and accessories for BG series mini-contactors

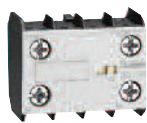

11BGX10... (20-11-02)  
11BGX1111



11BGX10... (40-31-22-13-04)  
11BGX1122



11BGXF...



11BGX77... -  
11BGX78225 -  
11BGX79...



11BGX5000

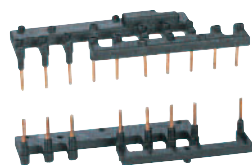

11SMX9021  
11SMX9022

Order code	Characteristics	Max qty per contactor	Qty per pkg	Wt
		n°	n°	[kg]

Auxiliary contacts.  
Screw terminals.

11BGX1002①	2NC	1	10	0.021
11BGX1011①	1NO + 1NC	1	10	0.021
11BGX1020①	2NO	1	10	0.021
11BGX1004②	4NC	1	10	0.028
11BGX1013②	1NO + 3NC	1	10	0.028
11BGX1022①	2NO + 2NC	1	10	0.028
11BGX1031①	3NO + 1NC	1	10	0.028
11BGX1040①	4NO	1	10	0.028

Auxiliary contacts for reversing and changeover assemblies.  
Screw terminals.

11BGX1111⑤	1NO + 1NC	1	10	0.021
11BGX1122⑤	2NO + 2NC	1	10	0.028

Auxiliary contacts.  
Faston terminals.

11BGXF1002④	2NC	1	10	0.021
11BGXF1011④	1NO + 1NC	1	10	0.021
11BGXF1020④	2NO	1	10	0.021
11BGXF1004④	4NC	1	10	0.028
11BGXF1013④	1NO + 3NC	1	10	0.028
11BGXF1022④	2NO + 2NC	1	10	0.028
11BGXF1031④	3NO + 1NC	1	10	0.028
11BGXF1040④	4NO	1	10	0.028

Mechanical interlock.

11BGX5000①	For BG...A and BG...D	1	10	0.008
------------	-----------------------	---	----	-------

Quick connect surge suppressors.

11BGX77048	≤48VAC/DC (Varistor)	10	0.007
11BGX77125	48...125VAC/DC (Varistor)	10	0.007
11BGX77240	125...240VAC/DC (Varistor)	10	0.007
11BGX78225	≤225VDC (Diode)	10	0.007
11BGX79048	≤48VAC (Resistor-Capacitor)	10	0.007
11BGX79125	48...125VAC (Resistor-Capacitor)	10	0.007
11BGX79240	125...240VAC (Resistor-Capacitor)	10	0.007
11BGX79415	240...415VAC (Resistor-Capacitor)	10	0.007

Modular shroud.

11BGX8000④	IP40 front protection	20	0.006
------------	-----------------------	----	-------

Paralleling links.

11G323⑥	For 2 poles	10	0.009
11G324		10	0.009
11G325⑥	For 4 poles	10	0.014
11G326		10	0.014

Rigid connecting kits.

11SMX9021⑥	Rigid connections for star-delta starter with BG... mini-contactors	10	0.040
11SMX9022⑥	Rigid connections for reversing switches with BG... mini-contactors	1	0.026

- ① Cannot be used with BG...L types.
- ② Cannot be used with BG...D and BG...L types.
- ③ Suitable for left-hand mini-contactor only of BGT and BGTP reversing and BGC changeover assemblies.
- ④ The shroud can be used with BG... types with screw termination only and with no auxiliary contacts, surge suppressor or mechanical interlock mounted. It raises the front degree of protection of the mini-contactor when these are used in consumer switchboards.
- ⑤ Cannot be used with BGX8000 shroud.
- ⑥ Contactors with one NC auxiliary contact, 01 type, are usually used. The SM1 breaker can be directly fitted with rigid connector; type connection SM1X3040P for SM1P... breaker and connection SM1X3040R for SM1R... breaker. The relay cannot be directly mounted on the contactor. Use the RF38 type and the RFX3804 independent mounting base.

### Operational characteristics

Type		BGX10... BGX11...	BGXF10...
IEC rated conventional free air thermal current Ith	A	10	10
IEC rated insulation voltage Ui	V	690	690
Terminals	Screw	M3	Faston 1x6.3mm 2x2.8mm
	Width	mm	6.9
Tightening torque	Nm	0.8...1	—
	lb.in	7...9	—
Conductor section maximum (with 1 or 2 cables)	flexible without lug	mm <sup>2</sup>	2.5
		mm <sup>2</sup>	2.5
	flexible with lug	mm <sup>2</sup>	2.5
		AWG	n°
UL/CSA and IEC/EN/BS 60947-5-1 designation	AC	A600	A600
	DC	Q600	Q600
Mechanical life (million)	cycles	20	20

### SM1 breaker - mini-contactor connecting kit

See page 1-12.

### Certifications and compliance

Certifications obtained:

Type	UL	cULus	EAC	CCC
BGX10...	—	●	●	●
BGX11...	—	●	●	●
BGXF10...	—	●	●	—
BGX5000	—	●	●	—
BGX7...	—	●	●	—
BGX8000	—	—	●	—
G32...	—	—	●	—
SMX90...	UL	—	—	—

● Certified products;

- UL - UL Recognized for USA only (File E197069) as Panel and Switchboard Accessories - Component. Products having this type of marking are intended for use as components of complete workshop-assembled equipment.
- cULus - UL Listed for USA and Canada (cULus - File E93601) as Auxiliary Devices - Component.

Compliant with standards: UL 60947-4-1, CSA C22.2 n° 60947-1, CSA C22.2 n° 60947-4-1; IEC/EN/BS 60947-1; IEC/EN/BS 60947-5-1 for auxiliary contacts.





## 2 Contactors

Add-on blocks and accessories for BG series mini-contactors

Combinations: mounting position on BG...A and BG...D mini-contactors

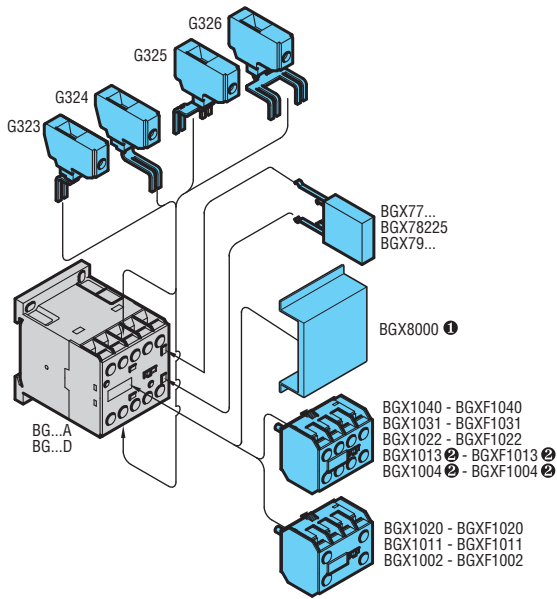

- ❶ Not suitable for mini-contactors BG... with auxiliaries contacts BGX10..., surge suppressor BGX7... and interlock BGX5000.
- ❷ Not suitable for BG...D types.

Combinations: mounting position on BG...L mini-contactors

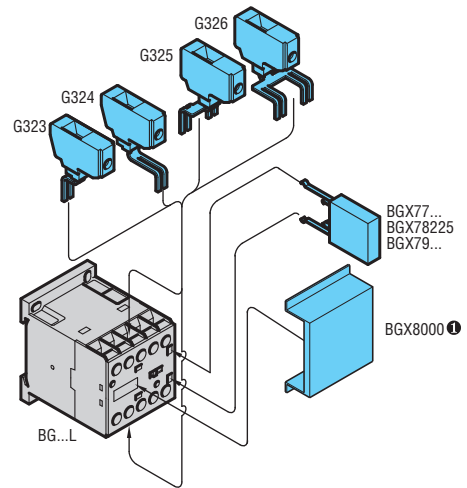

Combinations for reversing and changeover contactors assembled with BG...A and BG...D types

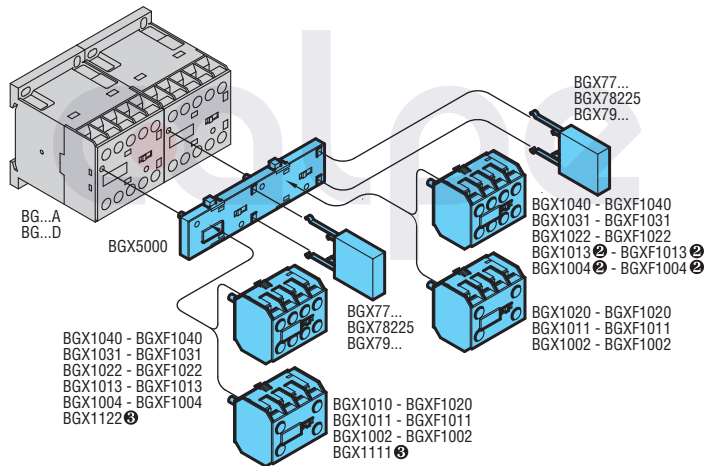

- ❷ Not suitable for BG...D types.
- ❸ For left-hand mini-contactor of BGT, BGTP and BGC contactor assemblies only. See page 4-5.

Connections for reversing contactor assembly

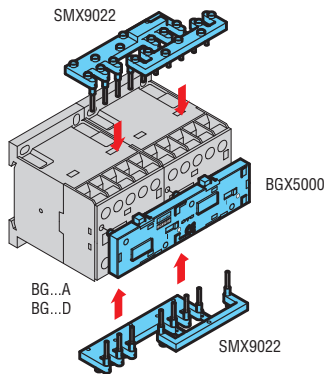

Connections for star-delta assembly

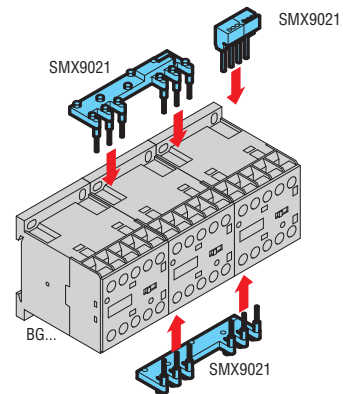



## 2 Contactors

Add-on blocks and accessories for contactors BF00, BF09...BF150



BFX10...



11G484...



BFX10...



11G418...

11G218



11G481...

11G482



11G428...



BFX12...



11G485...

11G486...

11G487

Order code	Characteristics	Max qty	Qty	Wt
		per cont.	per pkg.	
		n°	n°	[kg]

Auxiliary contacts with front center mounting .  
Screw terminals.

<b>BFX1002</b>	2NC	1	5	0.030
<b>BFX1011</b>	1NO + 1NC	1	5	0.030
<b>BFX1020</b>	2NO	1	5	0.030
<b>11G48403</b>	3NC	1	5	0.039
<b>11G48412</b>	1NO + 2NC	1	5	0.039
<b>11G48421</b>	2NO + 1NC	1	5	0.039
<b>11G48430</b>	3NO	1	5	0.039
<b>BFX1004</b>	4NC	1	5	0.048
<b>BFX1013</b>	1NO + 3NC	1	5	0.048
<b>BFX1022</b>	2NO + 2NC	1	5	0.048
<b>BFX1031</b>	3NO + 1NC	1	5	0.048
<b>BFX1040</b>	4NO	1	5	0.048
<b>BFX101111</b>	1NO+1NC and 1EM+1LB	1	5	0.048

Auxiliary contacts with front lateral mounting. Screw terminals.

<b>11G41801</b>	1NC	2	10	0.014
<b>11G41801D</b>	1LB	2	10	0.014
<b>11G41810</b>	1NO	2	10	0.014
<b>11G41810A</b>	1EM	2	10	0.014

Auxiliary contacts with front lateral mounting. Faston terminals.

<b>11G218</b>	1NO or 1NC reversible	2	10	0.011
<b>11G48102</b>	2NC	2	10	0.013
<b>11G48111</b>	1NO + 1NC	2	10	0.013
<b>11G48120</b>	2NO	2	10	0.013
<b>11G482</b>	Changeover contact	2	10	0.013

Adapter for auxiliary contact side mounting.

<b>11G280</b>	for G218	2	10	0.008
<b>11G419</b>	for G418	2	10	0.010
<b>11G483</b>	for G481 and G482	2	10	0.010

Auxiliary contacts with low side mounting. Screw terminals.

<b>BFX1202</b>	2NC	2	5	0.044
<b>BFX1211</b>	1NO+1NC	2	5	0.044
<b>BFX1220</b>	2NO	2	5	0.044
<b>11G42801</b>	1NC	2	10	0.024
<b>11G42801D</b>	1LB	2	10	0.024
<b>11G42810</b>	1NO	2	10	0.024
<b>11G42810A</b>	1EM	2	10	0.024

Delayed auxiliary contacts 1NO + 1NC (pneumatic operation) on energisation for front center mounting .

<b>11G4853</b>	3s	1	1	0.040
<b>11G4856</b>	6s	1	1	0.040
<b>11G48515</b>	15s	1	5	0.040
<b>11G48530</b>	30s	1	5	0.040
<b>11G48560</b>	60s	1	5	0.040
<b>11G485120</b>	120s	1	1	0.040

Delayed auxiliary contacts 1NO + 1NC (pneumatic operation) on de-energisation for front center mounting .

<b>11G4863</b>	3s	1	1	0.040
<b>11G4866</b>	6s	1	1	0.040
<b>11G48615</b>	15s	1	5	0.040
<b>11G48630</b>	30s	1	5	0.040
<b>11G48660</b>	60s	1	5	0.040
<b>11G486120</b>	120s	1	1	0.040
<b>11G487</b>	70ms	1	1	0.040

### Operational characteristics for add-on auxiliary contacts

Type		G418	G484	G218	G482
		G428	BFX10	G481	
		G485	BFX12		
		G486			
		G487			
IEC conventional free air thermal current Ith	A	10	10	10	0.1
IEC rated insulation voltage Ui	V	690	690	690	690
Terminals	Screw	M3.5	M3	—	—
	Width	mm	7	7	—
	Faston		—	—	1x6.35 2x2.8
Tightening torque	Nm	0.8...1	0.8...1	—	—
	lb.in	7...9	7...9	—	—
Conductor section maximum with (1 or 2 cables)	flexible w/o lug	mm <sup>2</sup>	2.5	2.5	—
	flexible c/w lug	mm <sup>2</sup>	2.5	2.5	2.5
	AWG	n°	14	14	14
Terminal protection per IEC/EN/BS 60529		IP20	IP20	IP20	IP20
UL/CSA and IEC/EN/BS 60947-5-1 designation	AC	A600	A600	A600	A600
	DC	P600	Q600	P600	P600
Mechanical life (million)	cycles	10	10	10	10

### SM1 breaker - contactor connecting kit

See page 1-12.

### Maximum assembly combination of add-on blocks

See pages 2-21 and 2-24...25.

### Certifications and compliance

Certifications obtained:

Type	UL	cULus	CSA	EAC	CCC
BFX10...	—		—		
BFX12...	—		—		—
G218		—			—
G418..., G428...		—			—
G481...		—			—
G482		—			—
G484...		—			—
G485...		—			—
G486...		—			—
G487...		—			—

Certified products; pending for BFX101111

UL Recognized for USA only (File E93601) as Auxiliary Devices - Component.

Products having this type of marking are intended for use as components of complete workshop-assembled equipment.

cULus - UL Listed for USA and Canada (cULus - File E93601) as Auxiliary Devices.

CSA - CSA certified for Canada only (File 54332) as Auxiliary Devices for motor controllers.

Add-on auxiliary contacts are compliant with the following standards: IEC/EN/BS 60947-1, IEC/EN/BS 60947-5-1, UL 60947-1, UL 60947-5-1, CSA C22.2 n° 60947-1, CSA C22.2 n° 60947-5-1;

The contacts can also be fitted on B type contactors using the adapter G358. See pages 2-30 and 2-31.

Highly conductive contacts.

Normally closed late-break contact.

Normally open early-make contact.

Gold-plated contacts inside tight casing for use in pollutant environments. The Ith value refers to 125VAC and 30VDC. Minimum applicable load: 5VDC 1mA.

IEC IP20 protection is warranted to equipment wired with insulated Faston terminals.

IEC IP20 protection is warranted to equipment wired with minimum 0.75mm<sup>2</sup> conductor section.

Designation in DC is Q600 for G418 and G419 types.

IEC IP20 protection is warranted to equipment wired with insulated Faston terminals.

IEC IP20 protection is warranted to equipment wired with minimum 1mm<sup>2</sup> conductor section. Mechanical life is 3 million cycles.

1.5mm<sup>2</sup> for insulated bootlace ferrules.

## 2 Contactors

Add-on blocks and accessories for contactors BF00, BF09...BF150

### BF00A, BF09A...BF150A, BF40E...BF150E

Maximum assembly combination for alternating-current contactors BF00A, BF09A...BF150.  
Maximum assembly combination for alternating/direct-current contactors BF40E...BF150E.

		Front centre mount				Front lateral mount			Side mount		
		BFX1002	BFX1004	G485...	G222... <sup>④</sup>	BFX5002	BFX5303	G418...	G428...	BFX1202	
		BFX1011	BFX1013	G486...	G272... <sup>④</sup>	BFX5003	BFX5403	G218	G419+ G418...	BFX1211	
		BFX1020	BFX1022	G487	BFX641... <sup>④</sup>			G481...	G280+ G218	BFX1220	
			BFX1031					G482	G483+ G481...	BFX5000 <sup>③⑤</sup>	
			BFX1040						G483+ G482	BFX5001 <sup>③⑤</sup>	
		n° of blocks 1 type only			n° of blocks	n° of blocks 1 type only		n° of blocks	n° of blocks	n° of blocks	
Contactors	Control relay	BF00A	1	1	1	1	—	1	1	1	
	Three poles	BF09A...BF25A	1	1	1	1	—	1	1	1	1
		BF26A...BF38A	1	1	1	1	—	1	1	1	1
		BF40A...BF150A	1	1	1	1	1	—	1	2	1
		BF40E...BF150E	1	1	1	1	—	1	1	2	1
	Four poles	BF09A...BF25A	1	1	1	1	1	—	1	1	1
		BF26A...BF38A	1	1	1	1	1	—	1	1	1
		BF40A...BF150A	1	1	1	1	—	1	1	2	1
		BF40E...BF150E	1	1	1	1	—	1	1	2	1

- ① Cannot be fitted with BFX10... with 4 contacts and G222.
- ② To fit the mechanical interlock, the add-on fourth pole needs to be mounted on the left side of the one of the contactors.
- ③ One only side-mount block can be fitted on each contactor whenever the BFX500... interlock is mounted.
- ④ One BFX10... or delayed G48... contact block can be mounted on the G222 or G272 mechanical latch.
- ⑤ G222 mechanical latch.
- ⑥ G272 mechanical latch for BF40...BF80; BFX641 for BF95...BF150.
- ⑦ For BF40...BF94 code BFX5300 or BFX5301; for BF95...BF150 code BFX5400 or BFX5401.
- ⑧ BFX5303 for BF40...BF94; BFX5403 for BF95...BF150.
- ⑨ BFX5303 cannot be mounted if a contact block BFX10... with 4 contacts (BFX1004, BFX1013, BFX1022, BFX1031, BFX1040) is installed.

### BF00D, BF09D...BF38D, BF00L, BF09L...BF38L

Maximum assembly combination for direct-current contactors BF00D, BF09D...BF38D  
Maximum assembly combination for direct-current contactors BF00L, BF09L...BF38L with low consumption

		Front centre mount							Front lateral mount		Side mount			
		BFX10...		BFX10...			G485...	G222...	1 type only BFX50...	BFX12...				
		...02	...11	...20	...04	...13	...22	...31	...40	...02	...03	...00	...01	
		n° of blocks 1 type only							n° of blocks	n° of blocks 1 type only				
Contactors	Control relay	BF00D	1	1	1	1	1	1	1	1	1	1	1	
		BF00L	1	—	—	—	—	—	—	—	—	—	—	
	Three poles	BF09D-BF25D	1	1	1	1	1	1	1	1	1	1	1	
		BF26D-BF38D	1	1	1	1	1	1	1	1	1	1	1	
		BF09L-BF25L	1	—	—	—	—	—	—	—	—	—	—	
		BF26L-BF38L	1	—	—	—	—	—	—	—	—	—	—	
	Four poles	BF09D-BF25D	1	1	1	1	1	1	1	1	1	1	1	
		BF26D-BF38D	—	1	—	—	—	—	—	—	1	1	1	1
		BF09L-BF25L	1	—	—	—	—	—	—	—	1	—	—	—
		BF26L-BF38L	—	1	—	—	—	—	—	—	1	—	—	—

- ① Mounting of BFX5003 interlock is not possible when BFX10... block with 4 contacts and G222 latch are mounted.
  - ② One only side-mount block can be fitted on each contactor whenever the BFX500... interlock is mounted.
  - ③ One BFX10... or delayed G48... contact block can be mounted on the G222 or G272 mechanical latch.
  - ④ To fit the mechanical interlock, the add-on fourth pole needs to be mounted on the left side of the one of the contactors.
- For other assembly combination, consult Technical support (E-mail: service@LovatoElectric.com).



## 2 Contactors

Add-on blocks and accessories for contactors BF00, BF09...BF150



**BFX42**  
**BFXD42**



**BFX5000**  
**BFX5300**  
**BFX5400**

**BFX5001**  
**BFX5301**  
**BFX5401**



**BFX5002**

**BFX5003**  
**BFX5303**  
**BFX5403**



**11G222...**  
**11G272...**  
**BFX641...**



**11G454**  
**11G455**  
**BFX642**

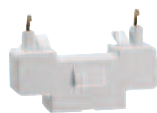

**BFX77...**  
**BFX79...**

Order code	Characteristics	Max qty per cont.	Qty per pkg	Wt [kg]
		n°	n°	[kg]
Fourth pole.				
<b>BFX42</b>	For BF26A, BF32A, BF38A	1	1	0.100
<b>BFXD42</b>	For BF26D, BF32D, BF38D, BF26L, BF32L, BF38L	1	1	0.108
<b>BFX43</b>	For BF40A...BF94A and BF40E...BF94E	1	1	0.150
<b>BFX44</b>	For BF95A...BF150A and BF95E...BF150E	1	1	0.500

Mechanical interlock.				
<b>BFX5000</b>	Side mount for BF00, BF09...BF38	1	5	0.039
<b>BFX5001</b>	Side mount with 2NC contacts for BF00, BF09...BF38	1	5	0.052
<b>BFX5002</b>	Front mount, low profile for BF00, BF09...BF38	1	5	0.006
<b>BFX5003</b>	Front mount for BF00, BF09...BF38	1	5	0.023
<b>BFX8910</b>	Spacer for interlocking BF09...BF38 AC/DC with types in DC	1	10	0.017
<b>BFX5300</b>	Side mount for BF40...BF94 A/E	1	5	0.039
<b>BFX5301</b>	Side mount with 2NC contacts for BF40...BF94 A/E	1	5	0.052
<b>BFX5303</b>	Front mount for BF40...BF94 A/E	1	5	0.034
<b>BFX5400</b>	Side mount for BF95...BF150 A/E	1	5	0.039
<b>BFX5401</b>	Side mount with 2NC contacts for BF95...BF150 A/E	1	5	0.052
<b>BFX5403</b>	Front mount for BF95...BF150 A/E	1	5	0.034

Mechanical latch. Screw terminals				
<b>11G222</b>	For BF00, BF09...BF38	1	1	0.070
<b>11G272</b>	For BF40...BF94	1	1	0.070
<b>BFX641...</b>	For BF95...BF150	1	1	0.070
Manual closing mechanism.				
<b>11G454</b>	For BF00, BF09...BF38	1	1	0.021
<b>11G455</b>	For BF40...BF94	1	1	0.021
<b>BFX642</b>	For BF95...BF150	1	1	0.021

Quick connect surge suppressors for BF00A, BF09A...BF150A contactors.				
<b>BFX77048</b>	≤48VAC/DC (Varistor)	5	0.012	
<b>BFX77125</b>	48...125VAC/DC (Varistor)	5	0.012	
<b>BFX77240</b>	125...240VAC/DC (Varistor)	5	0.012	
<b>BFX79048</b>	≤48VAC (Resistor-Capacitor)	5	0.012	
<b>BFX79125</b>	48...125VAC (Resistor-Capacitor)	5	0.012	
<b>BFX79240</b>	125...240VAC (Resistor-Capacitor)	5	0.012	
<b>BFX79415</b>	240...415VAC (Resistor-Capacitor)	5	0.012	

- ① Different sized contactors can be interlocked. Example: BF09...BF25 with BF26...BF38.
- ② Replace with the digit of the voltage if 50 or 60Hz and with the letter C followed by the digit of the voltage if DC. Standard voltages are:
  - AC 50/60Hz 24 (indicate 24) - 48 (indicate 48) - 110...125 (indicate 110) - 220...240 (indicate 220) - 380...415V (indicate 380) - 12 (indicate 12) - 24 (indicate 24) - 48 (indicate 48) - 110...125 (indicate 110) - 220...240V (indicate 220).
  - DC

NOTE: All contactors BF series, equipped with DC or AC/DC electronic coil, have built-in surge suppressor filter.

### Operational characteristics

Type		BFX42 BFXD42	BFX43	BFX44	BFX5001 BFX5301 BFX5401
IEC conventional free air thermal current Ith	A	56	115	165	10
IEC rated insulation voltage Ui	V	690	1000	1000	690
Terminals: Screw		M4	M6	M8	M3
Width	mm	12.5	9.6	14.5	7
Tightening torque	Nm	2.5...3	4...5	5.5...6.5	0.8...1
	lb.in	21.6...26.4	35.4...44.2	48...57	7...9
Conductor section maximum with 1 or 2 cables					
flexible w/o lug	mm <sup>2</sup>	16	35	70	2.5
flexible c/w lug	mm <sup>2</sup>	16	35	70	2.5
AWG	n°	6	2	2/0	14
Terminal protection for IEC/EN/BS 60529		IP20	IP20	IP20	IP20
UL/CSA and IEC/EN/BS 60947-5-1 designation	AC	---	---	---	A600
	DC	---	---	---	Q600
Mechanical life (million)	cycles	20	15	15	10

Type		G222...	G272...	BFX641	
Rated control circuit voltage	AC (50/60Hz)	V	24...415	24...415	24...415
	DC	V	12...240	12...240	12...240
Power consumption with control:	AC	VA	40	40	40
	DC	W	70	70	70
Minimum energising:					
drop-out	ms	10	10	10	
pick-up	ms	100	200	200	
Tightening torque	Nm	0.8...1	0.8...1	0.8...1	
	lb.in	7...9	7...9	7...9	
Conductor section Maximum with 1 or 2 cables					
flexible w/o lug	mm <sup>2</sup>	4	4	4	
flexible c/w lug	mm <sup>2</sup>	2.5	2.5	2.5	
AWG	n°	14...12	14...12	14...12	
Mechanical life (million)	cycles	0.1	0.1	0.1	

③ The condition is front IP20 protection.

### Maximum assembly combination of add-on blocks

See pages 2-21, 2-24...25.

### Certifications and compliance

Certifications obtained:

Type	UL	cULus	CSA	EAC
BFX42 - BFXD42 - BFXD43	---	●	---	●
BFX5...	---	●	---	●
BFX77... - BFX79...	---	●	---	●
G222... - G272... - BFX641	UL	---	●	●

- Certified products.
- UL - UL Recognized for USA only (File E93601) as Auxiliary Devices Component. Products having this type of marking are intended for use as components of complete workshop-assembled equipment.
- cULus - UL Listed for USA and Canada (cULus - File E93602) as Magnetic motor controllers.
- CSA - CSA certified for Canada only (File 54332) as Auxiliary Devices for motor controllers.

Compliant with standards: IEC/EN/BS 60947-1, UL 60947-1, CSA C22.2 n° 60947-1. IEC/EN/BS 60947-5-1, UL 60947-5-1, CSA C22.2 n° 60947-5-1 for auxiliary contacts IEC/EN/BS 60947-4-1, UL 60947-4-1, CSA C22.2 n° 60947-4-1 for four poles.

## 2 Contactors

Add-on blocks and accessories for contactors BF00, BF09...BF150



**BFX310...**  
**BFX3201**

**BFX3301**  
**BFX3401**

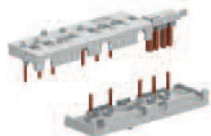

**BFX3131**  
**BFX3231**

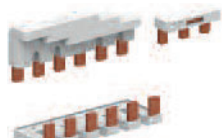

**BFX3331**  
**BFX3431**

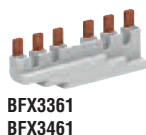

**BFX3361**  
**BFX3461**

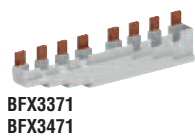

**BFX3371**  
**BFX3471**

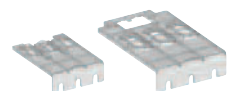

**BFX833**  
**BFX834**



**BFX3393**

**BFX3392**  
**BFX3492**



**11BA135**  
**11BA235**

**11BA435**



**11G231**  
**11G232**



**BFX3399**



**BFX8901**



**BFX80**



**BFX8902**

Order code	Characteristics	Qty per pkg	Wt [kg]
	Rigid connecting kits for three-pole reversing contactor assembly.	n°	[kg]
<b>BFX3101</b>	For contactors BF09...BF25 side by side with BFX5002 or BFX5003 mechanical interlock	1	0.052
<b>BFX3102</b>	For contactors BF09...BF25 side by side with BFX5000 or BFX5001 mechanical interlock	1	0.054
<b>BFX3201</b>	For contactors BF26...BF38 side by side with BFX50... mechanical interlock	1	0.060
<b>BFX3301</b>	For contactors BF40...BF94 side by side with BFX5303 mechanical interlock	1	0.150
<b>BFX3401</b>	For contactors BF95...BF150 side by side with BFX5403 mechanical interlock	1	0.200
	Rigid connecting kits for star-delta starters.		
<b>BFX3131</b>	For contactors BF09...BF25	1	0.058
<b>BFX3231</b>	For contactors BF26...BF38	1	0.064
<b>BFX3232</b>	For contactors BF26...BF38 (L/Δ) BF09...BF25 (Λ)	1	0.064
<b>BFX3332</b>	For contactors BF40...BF94 (L/Δ) BF26...BF38 (Λ)	1	0.200
<b>BFX3331</b>	For contactors BF40...BF94	1	0.220
<b>BFX3432</b>	For contactors BF95...BF150 (L/Δ) BF40...BF94 (Λ)	1	0.250
<b>BFX3431</b>	For contactors BF95...BF150	1	0.270
	Rigid connecting kits for changeovers.		
<b>BFX3361</b>	For three pole contactors BF40...BF94 with BFX5300/BFX5301 mechanical interlock	1	0.150
<b>BFX3461</b>	For three pole contactors BF95...BF150 with BFX5400/BFX5401 mechanical interlock	1	0.200
<b>BFX3371</b>	For four pole contactors BF40...BF80 with BFX5300/BFX5301 mechanical interlock	1	0.200
<b>BFX3471</b>	For four pole contactors BF95...BF150 with BFX5400/BFX5401 mechanical interlock	1	0.300
	IP20 protection for power terminals. 2 pieces for each contactor are required.		
<b>BFX833</b>	For contactors BF40...BF94	10	0.020
<b>BFX834</b>	For contactors BF95...BF150	10	0.030
	Non insulated paralleling links.		
<b>11BA135</b>	2 poles for contactors BF09...BF25 types	10	0.001
<b>11BA235</b>	2 poles for contactors BF26...BF38 types	10	0.003
<b>BFX3392</b>	2 poles for contactors BF40...BF94 types	4	0.022
<b>BFX3492</b>	2 poles for contactors BF95...BF150 types	4	0.027
<b>BFX3393</b>	3 poles for contactors BF40...BF94 types	4	0.038
<b>11BA435</b>	3 poles for contactors BF95...BF150 types	10	0.030
	Insulated paralleling link with terminal.		
<b>BFX3399</b>	3 pole (for contactors BF40...BF94) Conductor section connectable: 25...95mm <sup>2</sup> (95mm <sup>2</sup> without lug)	10	0.135
	One-pole enlarged terminals.		
<b>11G231</b>	1x6mm <sup>2</sup> for contactors BF09...BF25 types	12	0.009
<b>11G232</b>	1x16mm <sup>2</sup> for contactors BF26...BF38 types	12	0.014
	Sealing cover.		
<b>BFX80</b>	Sealing cover for contactors BF00 and BF09...BF38	10	0.001
	Screw fixing adapters for contactors.		
<b>BFX8901</b>	Universal base to screw fix BF09...BF38 contactors	5	0.016
<b>BFX8902</b>	Screw fixing brackets for BF09...BF38 contactors	10	0.002
	Marking element for BF00, BF09...BF150 contactors.		
<b>BFX30</b>	Blank label for writing	50	0.001

### Operational characteristics

Type		BFX3399	11G231	11G232
Tightening torque	Nm	13Nm	1.5-1.8	2.5-3
	lb.in	115	13.2-18	7-9
Tool	Type	Allen key 6	PH1	PH2

### Certifications and compliance

Certifications obtained: UL Listed for USA and Canada (cULus - File E93602), for all connecting kits for starters and changeovers BFX3...; EAC.  
Compliant with standards: IEC/EN/BS 60947-1, UL 60947-1, CSA C22.2 n° 60947-1.



## 2 Contactors

Add-on blocks and accessories for contactors BF00, BF09...BF150

### Add-on blocks for AC and AC/DC contactors

Combinations: mounting position on BF00A and BF09A...BF150A contactors  
Table with combinations: See page 2-21.

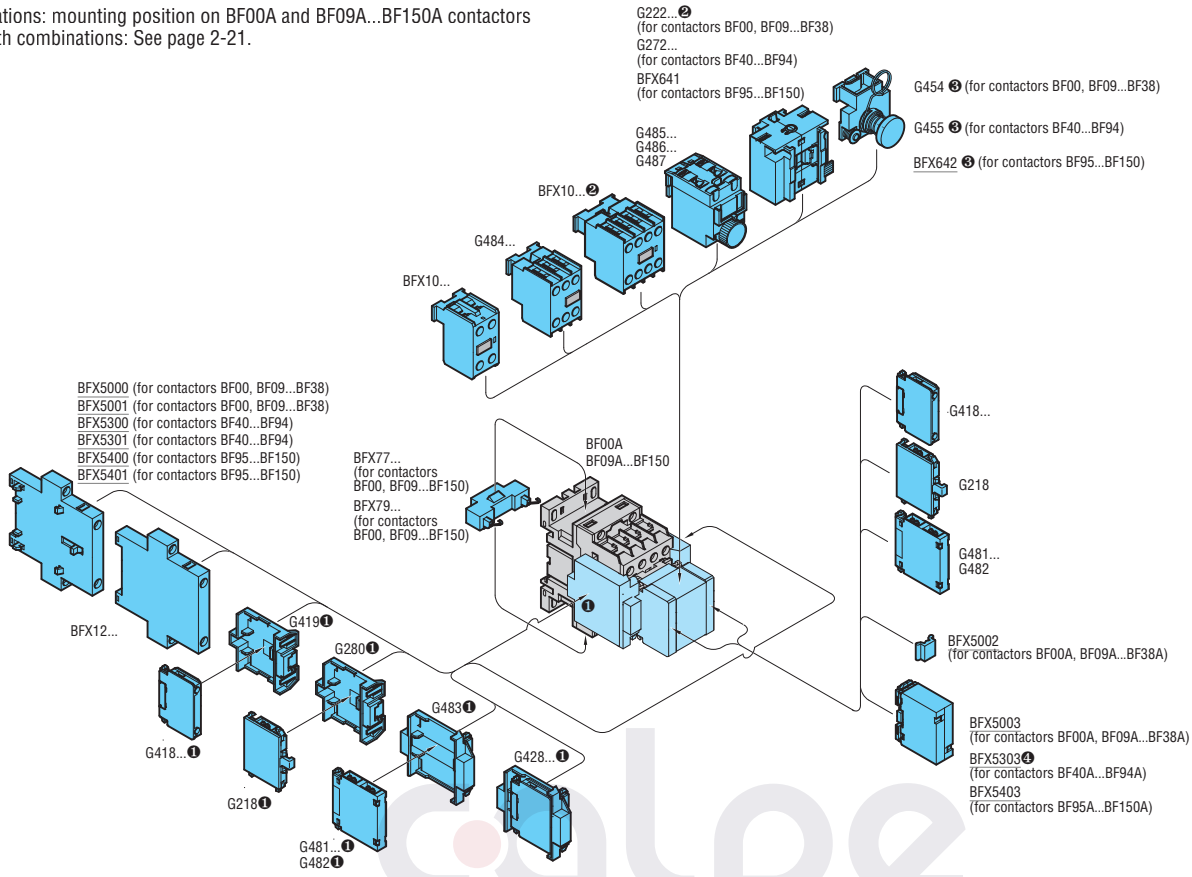

- ❶ Mounting is not possible if front lateral contacts or mechanical interlock BFX5000 or BFX5001 are mounted. BF00, BF09...38 cannot be fitted with BFX10 with 4 contacts or G222...
- ❷ Refer to the diagram below for use with G222... on contactors BF00A and BF09A...BF38A and to the table of combinations on page 2-21.
- ❸ No add-on block can be mounted on front when the manual closing mechanism G454 or G455 is fitted.
- ❹ BFX5303 cannot be mounted if a contact block BFX10... with 4 contacts (BFX1004, BFX1013, BFX1022, BFX1031, BFX1040) is installed.

Combinations: mounting position on BF00A and BF09A-BF38A contactors with mechanical latch G222 fitted.  
Table with combinations: See page 2-21.

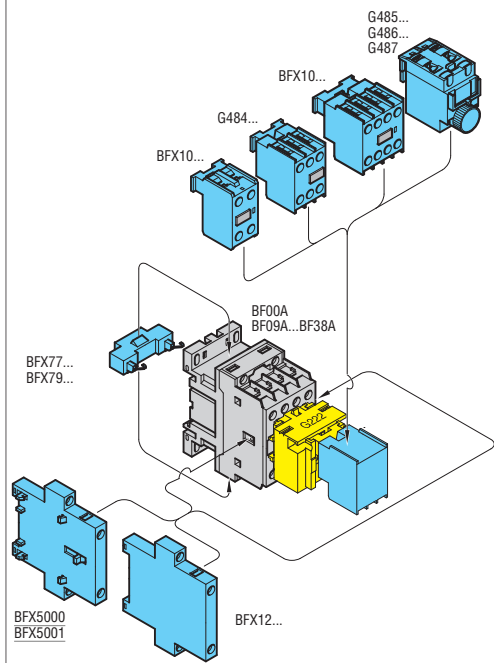

Combinations: mounting position on BF40A...150A, BF40E...BF150E, contactors with mechanical latch G272 fitted.  
Table with combinations: See page 2-21.

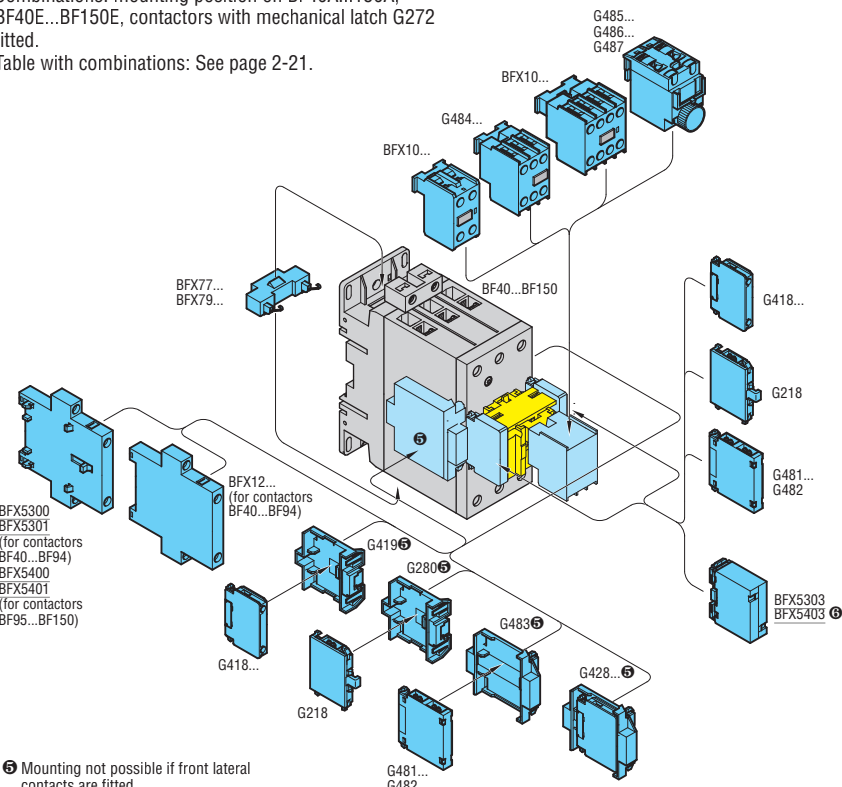

- ❺ Mounting not possible if front lateral contacts are fitted.
- ❻ Mounting only for BF95...BF150



## 2 Contactors

Add-on blocks and accessories for contactors BF00, BF09...BF150

### Add-on blocks for DC and DC low consumption contactors

Combinations: mounting position on BF00 and BF09-BF38, D and L versions  
Table with combinations: See page 2-21.

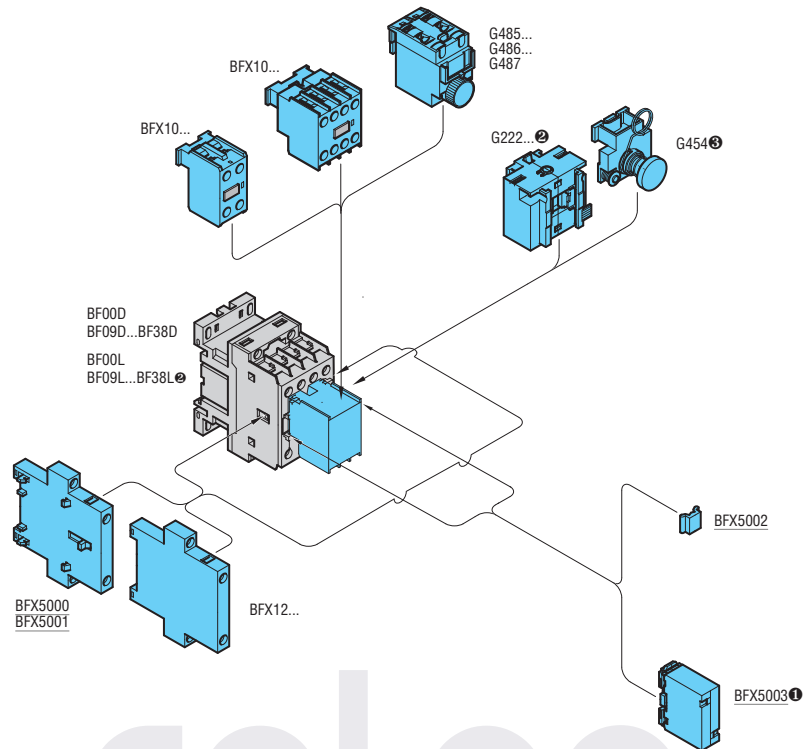

- ❶ Mounting not possible when the G222 mechanical latch is fitted.
- ❷ The G222 mechanical latch cannot be fitted on BF26L - BF38L four-pole types.
- ❸ No add-on block can be mounted on front when the G454 manual closing mechanism is fitted.

### Accessories for AC, DC and DC low consumption contactors

Combinations

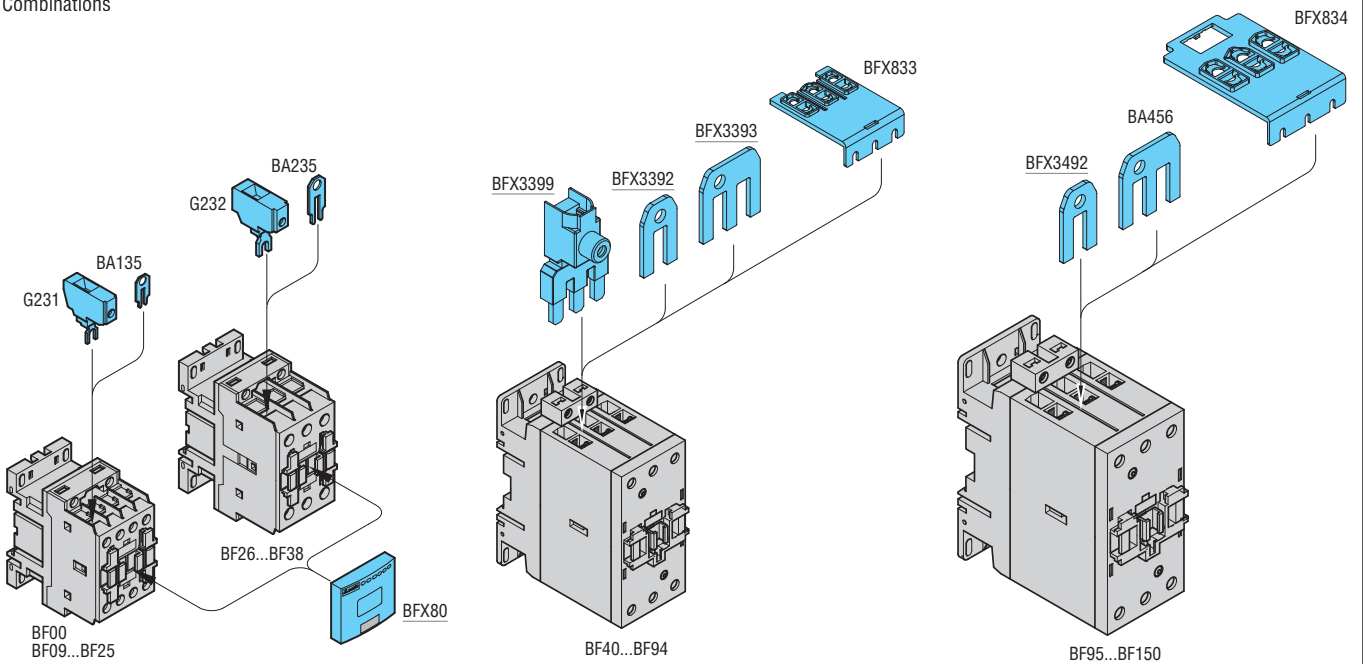



## 2 Contactors

Add-on blocks and accessories for contactors BF00, BF09...BF150

### Accessories for AC, DC and DC low consumption contactors

Rigid connecting kits for three-pole reversing contactor assembly. For BF09...BF25

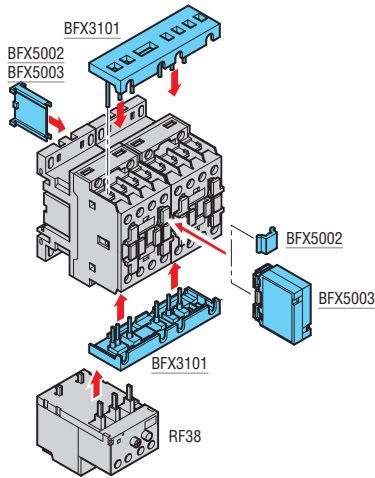

Rigid connecting kits for three-pole reversing contactor assembly. For BF09...BF25 and mechanical interlock BFX5000 or BFX5001

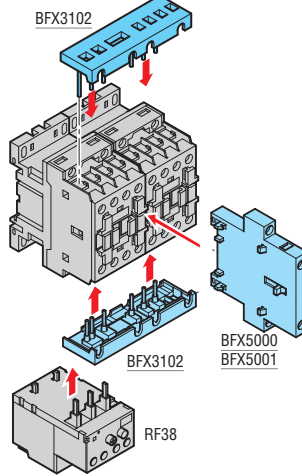

Rigid connecting kits for three-pole reversing contactor assembly. For BF26...BF38

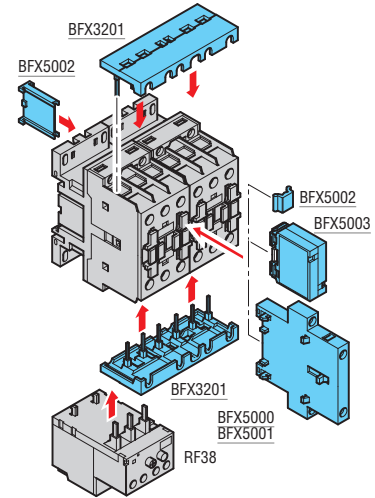

Rigid connecting kits for three-pole reversing contactor assembly. For BF40...BF94

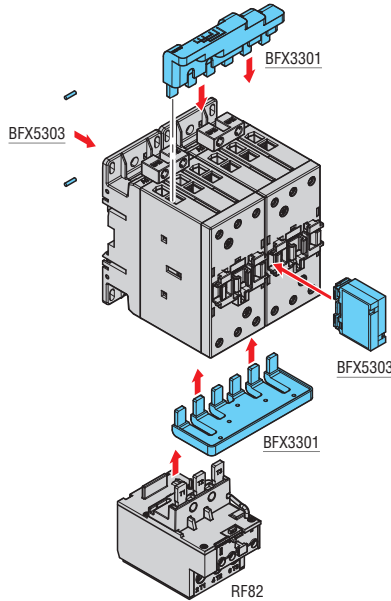

Rigid connecting kits for three-pole reversing contactor assembly. For BF95...BF150

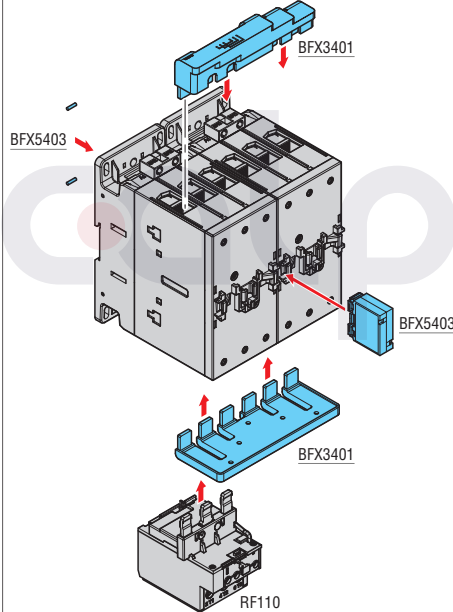

Rigid connecting kits for three-pole reversing contactor assembly. For BF09...BF25 contactors

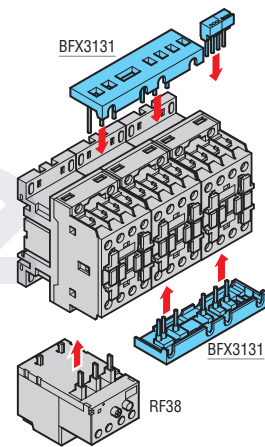

Rigid connecting kits for three-pole reversing contactor assembly. For BF26...BF38 (line-delta) and BF09...BF25 (star) contactors

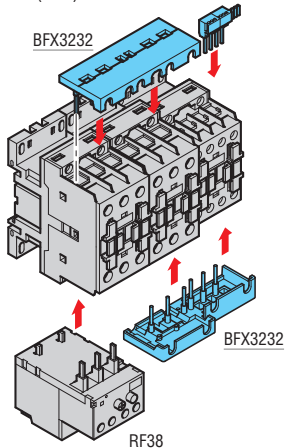

Rigid connecting kits for three-pole reversing contactor assembly. For BF26...BF38 contactors

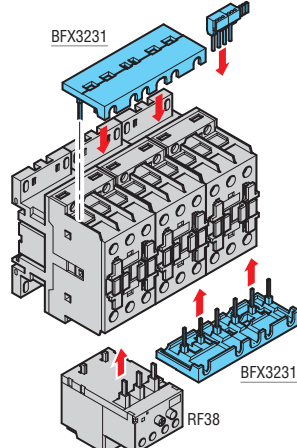

Rigid connecting kits for three-pole reversing contactor assembly. For BF40...BF94 (line-delta) and BF26...BF38 (star) contactors

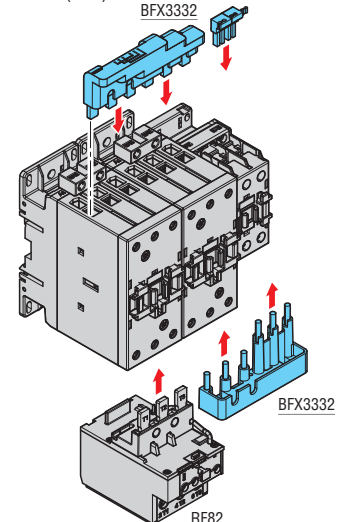

## 2 Contactors

Add-on blocks and accessories for contactors BF00, BF09...BF150

Rigid connecting kits for three-pole reversing contactor assembly. For BF40...BF94 contactors

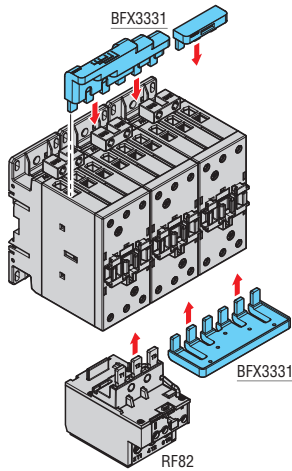

Rigid connecting kits for three-pole reversing contactor assembly. For BF95...BF150 (line-delta) and BF40...BF94 (star) contactors

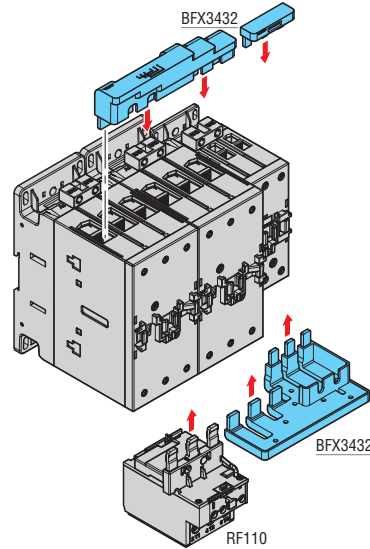

Rigid connecting kits for three-pole reversing contactor assembly. For BF95...BF150 contactors

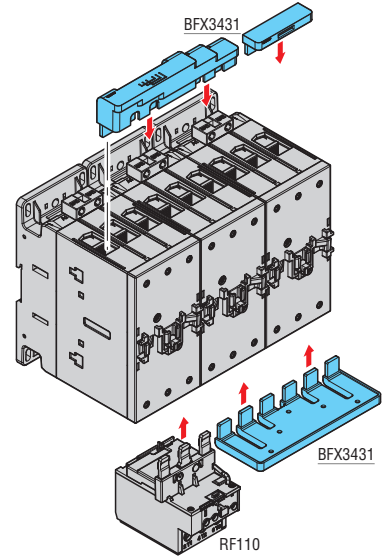

Rigid connecting kits for three-pole reversing contactor assembly. For BF40...BF94 contactors

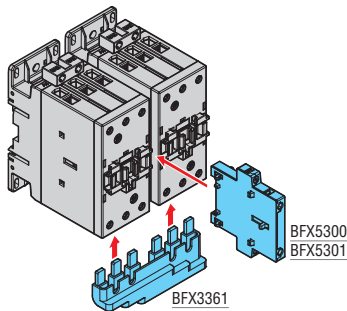

Rigid connecting kits for three-pole reversing contactor assembly. For BF95...BF150 contactors

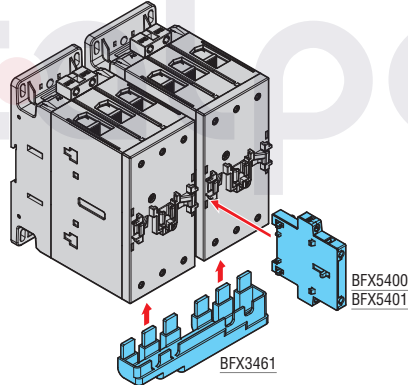

Rigid connecting kits for four-pole reversing contactor assembly. For BF40...BF94 contactors

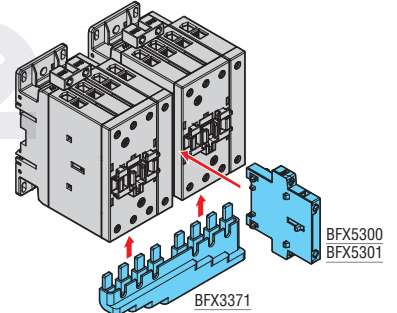

Rigid connecting kits for four-pole reversing contactor assembly. For BF95...BF150 contactors

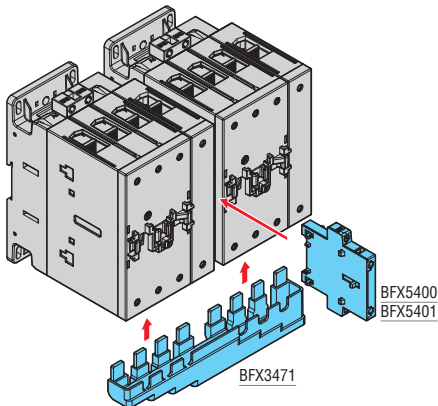



## 2 Contactors

Add-on blocks and accessories for contactors BF160...BF230

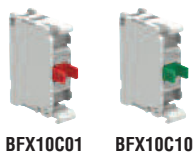

BFX10C01 BFX10C10

**new**



BFX12C...

**new**



BFX5500

BFX5503  
BFX5504

**new**

**new**

**new**



BFX815

**new**



BFX835

BFX845

**new**



BFX805



GLX500  
GLX501

GMX500

GMX501



BFX3583

BFX3584

Order code	Characteristics	Max qty per cont. n°	Qty per pkg. n°	Wt [kg]
------------	-----------------	----------------------	-----------------	---------

Auxiliary contacts with front mounting  
Screw terminals.

<b>BFX10C10</b>	1NO	6	5	0.048
<b>BFX10C01</b>	1NC	6	5	0.048

Auxiliary contacts with low side mounting.  
Screw terminals.

<b>BFX12C02</b>	2NC	2	5	0.048
<b>BFX12C11</b>	1NO + 1NC	2	5	0.048
<b>BFX12C20</b>	2NO	2	5	0.048

Mechanical interlock.

<b>BFX5500</b>	For contactors BF160...BF230. Side by side mounting.	1	1	0.050
<b>BFX5503</b>	For contactors BF160...BF230. One on top of other mounting. Interaxis: 305...345mm	1	1	0.150
<b>BFX5504</b>	For contactors BF160...BF230. One on top of other mounting. Interaxis: 345...385mm	1	1	0.200

Order code	Characteristics	Qty per pkg. n°	Wt [kg]
------------	-----------------	-----------------	---------

Power terminal protection.

<b>BFX815</b> ①	One-pole terminal cover for BF160...BF230	6	0.026
<b>BFX835</b>	Three-pole terminal cover for BF16000...BF23000	1	0.050
<b>BFX845</b>	Four-pole terminal cover for BF160T4...BF230T4	1	0.070

**new**

**new**

Phase barrier.

<b>BFX805</b>	For BF160...BF230 order 4 pcs for three-pole contactors order 6 pcs for four-pole contactors	4	0.010
---------------	--	---	-------

Terminal clamp sets for rigid and flexible cables.

<b>GLX500</b>	1-piece set, each covers 1 pole. For AWG 6...kcmil 250 wires	1	0.011
<b>GLX501</b>	3-piece set, each covers 1 pole. For AWG 6...kcmil 250 wires	1	0.011
<b>GMX500</b> ②	6-piece set, each covers 1 pole. For AWG 14...2/O wires	1	0.200
<b>GMX501</b>	6-piece set, each covers 1 pole. For AWG 4...kcmil 300 wires	1	0.200

**new**

Connecting kits

<b>BFX3583</b>	Terminal enlargement for three-pole contactors BF160...BF230	1	0.100
<b>BFX3584</b>	Terminal enlargement for four-pole contactors BF160...BF230	1	0.130
<b>BFX3592</b>	Two-pole non insulated paralleling link	1	0.050
<b>BFX3593</b>	Three-pole non insulated paralleling link	1	0.070
<b>BFX3501</b>	Connecting kit for reversing contactor assembly	1	1.000
<b>BFX3531</b>	Connecting kits for star-delta starter	1	1.100
<b>BFX3561</b>	Rigid connecting kit for three-pole changeover	1	0.900
<b>BFX3571</b>	Rigid connecting kit for four-pole changeover	1	1.200
<b>BFX8508</b>	Captive nut	8	0.009

① It is supplied for one terminal only. Example: for three-pole contactor, order 3 pieces for the upper terminals or 6 pieces for all the upper and lower terminals.

② For currents higher than 175A, 2 pieces can be mounted for each contactor terminal.

### Operational characteristics for add-on auxiliary contacts

Type		BFX10C10 BFX10C01	BFX12
IEC conventional free air thermal current I <sub>th</sub>	A	10	10
IEC rated insulation voltage U <sub>i</sub>	V	690	690
Terminals Screw		M3.5	M3
	Width	mm 7	7
Tightening torque	Nm	0.8...1	0.8...1
	lb.in	7...9	7...9
Conductor section maximum with (1 or 2 cables)	flexible w/o lug	mm <sup>2</sup> 2.5	2.5
	flexible c/w lug	mm <sup>2</sup> 2.5	2.5
	AWG	n° 14	14
	Terminal protection per IEC/EN/BS 60529		IP20
UL/CSA and IEC/EN/BS 60947-5-1 designation	AC	A600	A600
	DC	Q600	Q600
Mechanical life (million)	cycles	10	10

### Certifications and compliance

Certifications obtained:

Type	cULus	EAC	CCC
BFX10C...	●	①	①
BFX12C...	●	①	①

① Pending.

## 2 Contactors

Add-on blocks and accessories for contactors BF160...BF230

Combinations: Mounting position on BF160...BF230 contactors

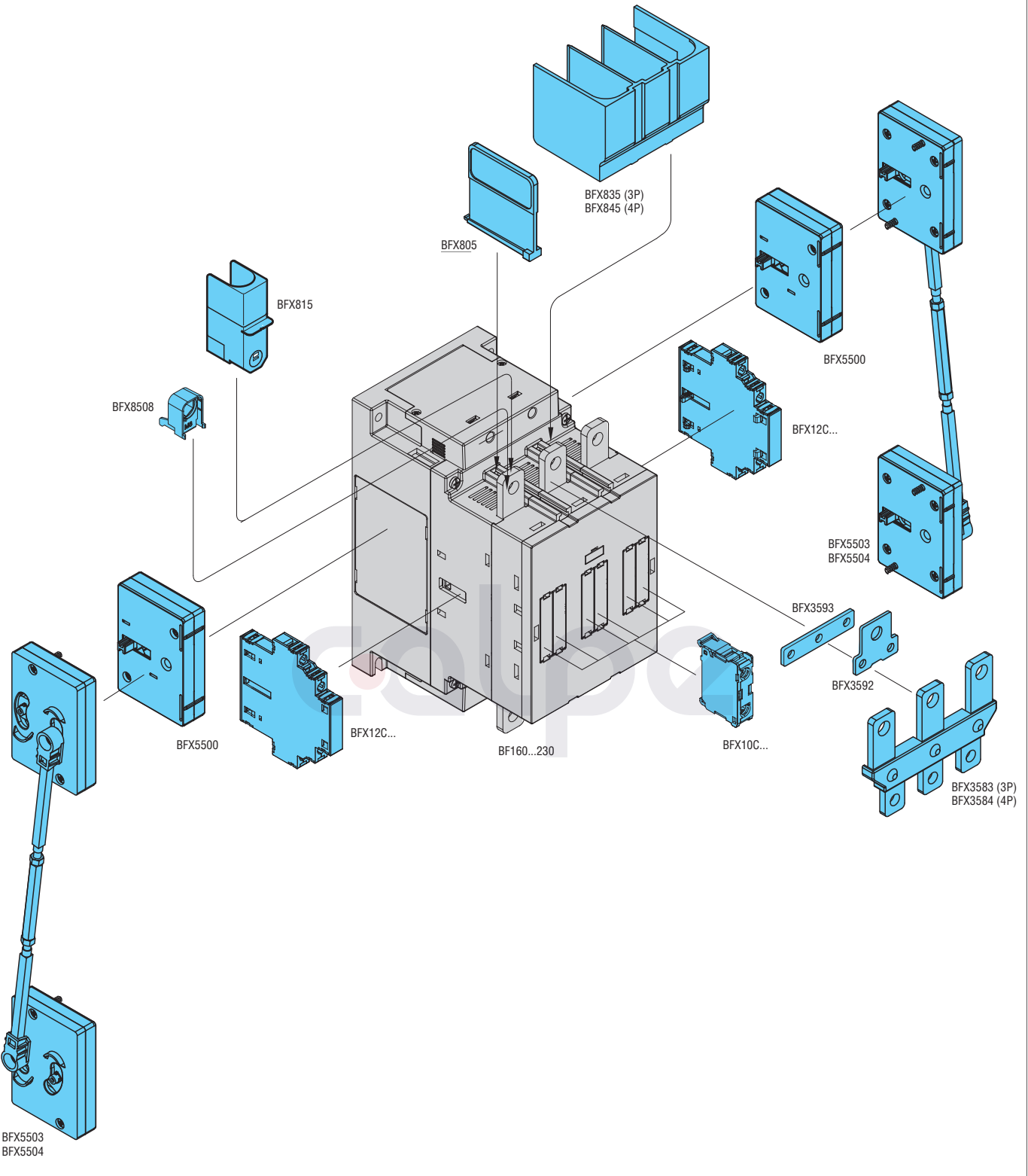



## 2 Contactors

Add-on blocks and accessories for B series contactors

### Add-on blocks



11G350 - 11G354



11G358

### Accessories



11G361 - 11G363



11G527 - 11G528 - 11G529  
11G530



11G370



11G371

Order code	Characteristics	Max qty per. contactor	Qty per pk	Wt sg
		n°	n°	[kg]

Auxiliary contacts.  
Faston terminals. Side mounting.

11G350①	2NO+1NC or 1NO+2NC reversible	4	1	0.082
11G354①	1NO+1NC	4	1	0.078

Adapter.

11G358	For fitting auxiliary contacts BFX10..., with 2 contacts, G484..., G485..., G486... and G487 on contactors B250...B6301000	4	5	0.050
--------	--	---	---	-------

Mechanical interlock.

11G355②③	Side by side	1	1	0.026
11G356 1②④	One on top of other	1	1	0.120
11G356 2②④	One on top of other	1	1	0.126
11G356 3②④	One on top of other	1	1	0.132
11G356 4②④	One on top of other	1	1	0.140
11G356 5②④	One on top of other	1	1	0.146
11G356 6②⑤	One on top of other	1	1	0.150

Mechanical latch.

11G495⑥⑦⑧	For B250...B630⑥	1	1	0.795
-----------	------------------	---	---	-------

Order code	Characteristics	Qty per pkg	Wt
		n°	[kg]

Power terminal protection.

11G363⑨	For contactors B250-B310-B400	6	0.046
11G527	For contactor B500	1	0.238
11G528	For contactor B5004	1	0.265
11G529	For contactor B630	1	0.238
11G530	For contactor B6304	1	0.266

3 pole star connecting bars.

11BA1721	For contactors B250-B310-B400	1	0.140
11BA1846	For contactors B500-B630	1	0.341

2 pole bars for parallel arrangement.

11BA1720	For contactors B250-B310-B400	1	0.149
11BA1845	For contactors B500-B630	1	0.322

Terminal adapter.

11G370	To transform Faston terminals of auxiliary contacts and coils into screw terminals	10	0.003
11G371	To transform both coil Faston terminals into screw terminals	5	0.022

### Operational characteristics of auxiliary contacts

Type	G350-G354	
IEC conventional free-air thermal current Ith	A	16
IEC rated insulation voltage Ui	V	690
Terminals	Faston	1-6.35x0.8 2-2.8x0.8
Conductor section maximum (with 1 or 2 cables)	flexible c/w lug	mm <sup>2</sup> 2.5
	AWG	n° 14
	UL/CSA and IEC/EN/BS 60947-5-1 designation	AC DC
Mechanical life (million)	cycles	5

Type	G495⑩	
Rated AC control circuit voltage	AC (50/60Hz)	V 48...480
	DC	V 48...480
Power consumption with control in:	AC	VA 1500
	DC	W 1100
Minimum energising:	drop-out	ms 40
	pick-up	ms 300
Terminals	Faston	1-6.3x0.8

Type	G370-G371	
Tightening torque	Nm	1
	lb.in	8.9
Tool	Type	PH2
	Conductor section (with 1 or 2 cables)	mm <sup>2</sup> 4 AWG 10

### Certifications and compliance

Certifications obtained:

Type	UL	CSA	EAC	CCC
G350	UL	●	●	●
G354	UL	●	●	---
G355	---	●	●	---
G356 ...	---	●	●	---
G361	---	●	●	---
G362	---	●	●	---
G363	---	●	●	---
G370	---	●	●	---

● Certified products.

UL - UL Recognized for USA only (File E93601) as Auxiliary Devices - Component.

Products having this type of marking are intended for use as components of complete workshop-assembled equipment.

CSA - CSA certified for Canada only (File 54332) as Auxiliary Devices for motor controllers.

Compliant with standards: IEC/EN/BS 60947-1, IEC/EN/BS 60947-4-1, UL 60947-1, UL 60947-4-1, IEC/EN/BS 60947-4-1, UL508, CSA C22.2 n° 14; add-on auxiliary contacts also comply with: IEC/EN/BS 60947-5-1, UL 60947-5-1, CSA C22.2 n° 60947-5-1.

① Only for B250-B310-B400-B500-B630-B6301000.

② Not suitable for B6301000-B1250-B1600 ⑤.

③ For use with three-pole B6301000, consult Technical support for information; see contact details on inside front cover.

④ Allowed distances see page 2-76.

⑤ For contactors B1250 and B1600, two G3566 mechanical interlocks are required.

⑥ Replace with the digit of the voltages if 50 or 60 Hz or with the letter C followed by voltage if DC. The standard voltages are:  
- AC 50/60Hz 48 - 110...125 (indicate 110) - 220...240 (indicate 220) - 380...415 (indicate 380)  
- DC 48 - 110...125 (indicate 110) - 220...240 (indicate 220).

⑦ It can be mounted only in contactors if predisposed for it. Technical support for information; see contact details on inside front cover.

⑧ Not suitable for B310 and B310 4.

⑨ Provided for one pole terminal only. Example: For three-pole contactors, purchase 3 pieces for the upper terminals only or 6 pieces for all upper and lower terminals.



## 2 Contactors

Add-on blocks and accessories for B series contactors

Combinations: Mounting position on B250...B630 contactors

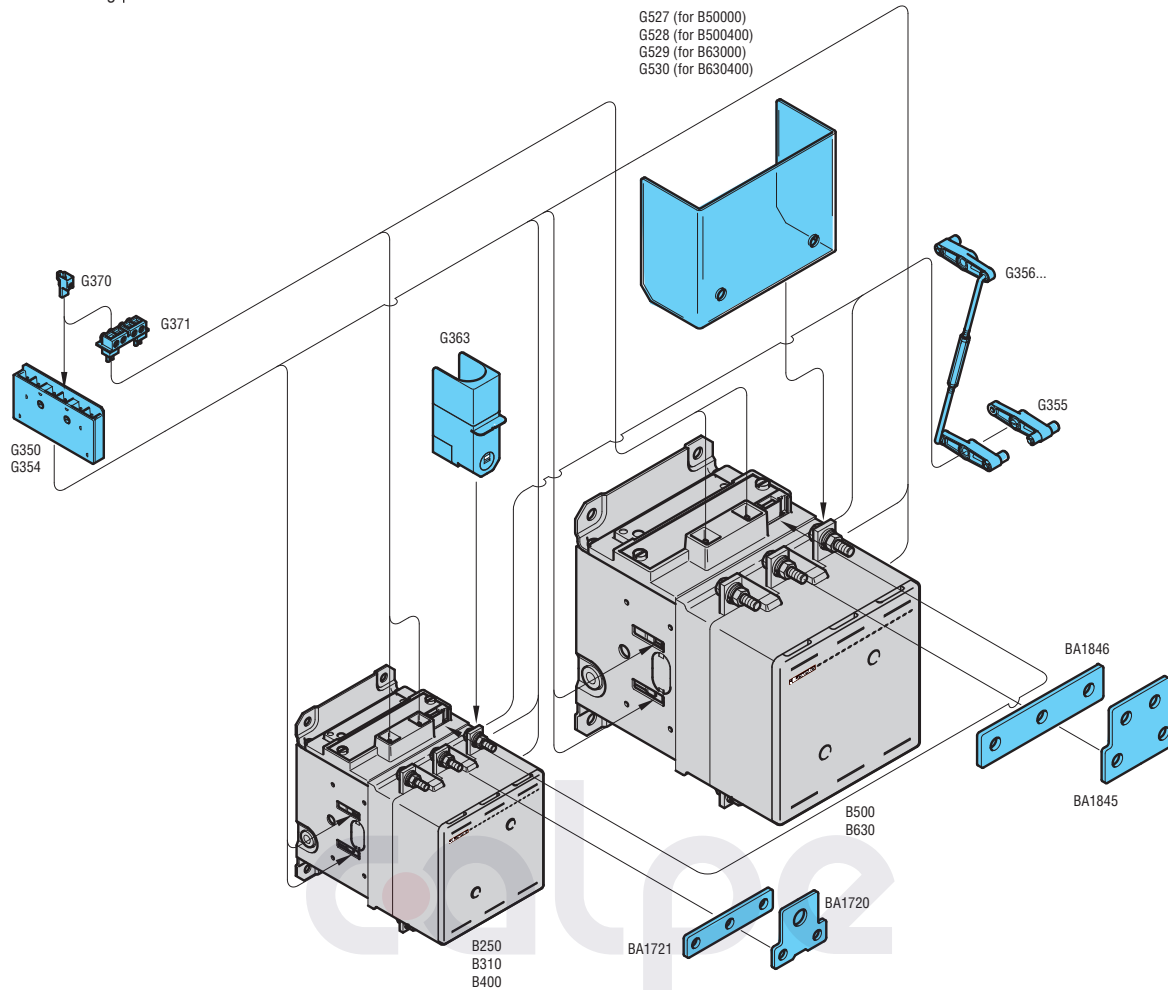

The add-on auxiliary contact blocks G350 and G354 can be applied to contactors B250-B6301000 only up to a maximum of four pieces for each contactor, for a total of 12 contacts.

The contact block G350 provides a 2NO+1NC or 1NO+2NC combination depending on its mounting position; see the drawing below. The G354 block consists of 1NO+1NC.

Contact blocks, BFX10 with 2 contacts, G484, G485, G486 and G487 types, can be mounted using the G358 adapter, refer to page 2-20 for exact types and order codes of the blocks.

A maximum of four adapters can be possibly used per contactor and each adapter can hold one BFX10, G484, G485, G486 and G487.

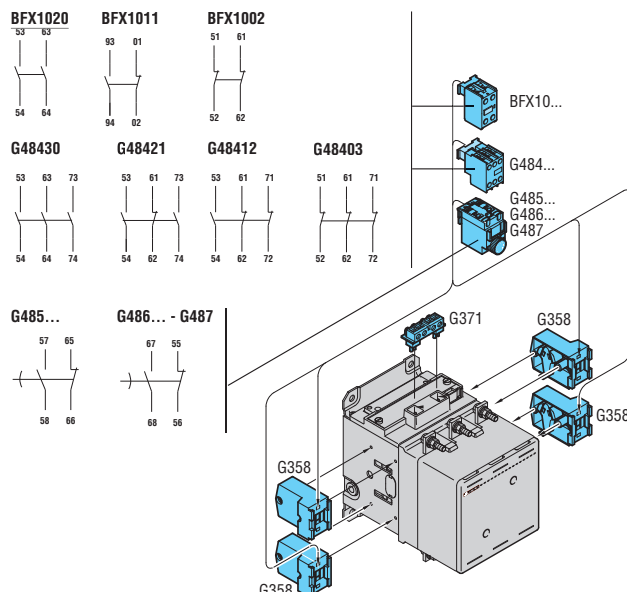
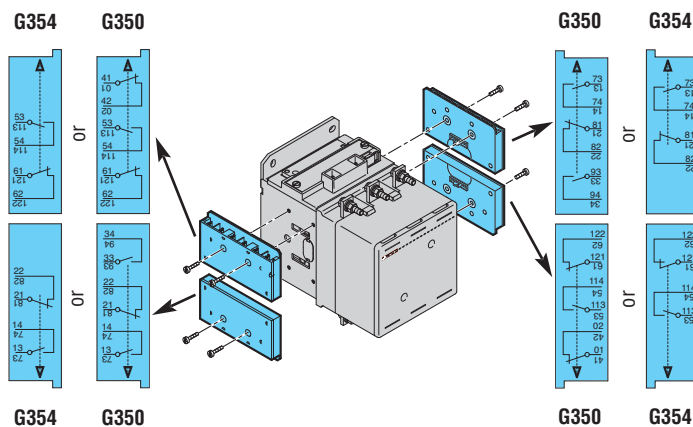





## 2 Contactors

Spare parts for BF series contactors

### AC coils



BFX91A...



BFX92A...

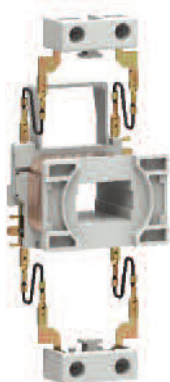

BFX93A...

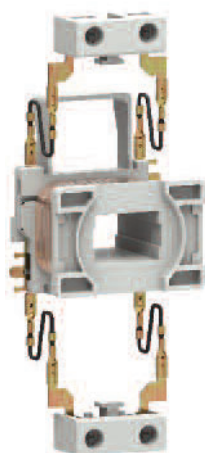

BFX94A...

Order code	Rated frequency and voltage		Qty per pkg n°	Wt [kg]
	[Hz]	[V]		
For contactors BF00A-BF09A-BF12A-BF18A-BF25A.				
<b>BFX91A024</b> Ⓢ	50/60	24VAC	1	0.085
<b>BFX91A048</b> Ⓢ		48VAC	1	0.085
<b>BFX91A110</b> Ⓢ		110VAC	1	0.085
<b>BFX91A230</b> Ⓢ		230VAC	1	0.085
<b>BFX91A400</b> Ⓢ		400VAC	1	0.085
<b>BFX91A024 60</b> Ⓢ	60	24VAC	1	0.085
<b>BFX91A048 60</b> Ⓢ		48VAC	1	0.085
<b>BFX91A120 60</b> Ⓢ		120VAC	1	0.085
<b>BFX91A220 60</b> Ⓢ		220VAC	1	0.085
<b>BFX91A230 60</b> Ⓢ		230VAC	1	0.085
<b>BFX91A460 60</b> Ⓢ		460VAC	1	0.085
<b>BFX91A575 60</b> Ⓢ		575VAC	1	0.085
For contactors BF26A-BF32A-BF38A.				
<b>BFX92A024</b> Ⓢ	50/60	24VAC	1	0.088
<b>BFX92A048</b> Ⓢ		48VAC	1	0.088
<b>BFX92A110</b> Ⓢ		110VAC	1	0.088
<b>BFX92A230</b> Ⓢ		230VAC	1	0.088
<b>BFX92A400</b> Ⓢ		400VAC	1	0.088
<b>BFX92A02460</b> Ⓢ	60	24VAC	1	0.088
<b>BFX92A04860</b> Ⓢ		48VAC	1	0.088
<b>BFX92A12060</b> Ⓢ		120VAC	1	0.088
<b>BFX92A22060</b> Ⓢ		220VAC	1	0.088
<b>BFX92A23060</b> Ⓢ		230VAC	1	0.088
<b>BFX92A46060</b> Ⓢ		460VAC	1	0.088
<b>BFX92A57560</b> Ⓢ		575VAC	1	0.088
For contactors BF40A-BF50A-BF65A-BF80A-BF94A.				
<b>BFX93A024</b> Ⓢ	50/60	24VAC	1	0.150
<b>BFX93A048</b> Ⓢ		48VAC	1	0.150
<b>BFX93A110</b> Ⓢ		110VAC	1	0.150
<b>BFX93A230</b> Ⓢ		230VAC	1	0.150
<b>BFX93A400</b> Ⓢ		400VAC	1	0.150
<b>BFX93A02460</b> Ⓢ	60	24VAC	1	0.150
<b>BFX93A04860</b> Ⓢ		48VAC	1	0.150
<b>BFX93A12060</b> Ⓢ		120VAC	1	0.150
<b>BFX93A22060</b> Ⓢ		220VAC	1	0.150
<b>BFX93A23060</b> Ⓢ		230VAC	1	0.150
<b>BFX93A46060</b> Ⓢ		460VAC	1	0.150
<b>BFX93A57560</b> Ⓢ		575VAC	1	0.150
For contactors BF95A-BF115A-BF150A.				
<b>BFX94A024</b> Ⓢ	50/60	24VAC	1	0.185
<b>BFX94A048</b> Ⓢ		48VAC	1	0.185
<b>BFX94A110</b> Ⓢ		110VAC	1	0.185
<b>BFX94A230</b> Ⓢ		230VAC	1	0.185
<b>BFX94A400</b> Ⓢ		400VAC	1	0.185
<b>BFX94A02460</b> Ⓢ	60	24VAC	1	0.185
<b>BFX94A04860</b> Ⓢ		48VAC	1	0.185
<b>BFX94A12060</b> Ⓢ		120VAC	1	0.185
<b>BFX94A22060</b> Ⓢ		220VAC	1	0.185
<b>BFX94A23060</b> Ⓢ		230VAC	1	0.185
<b>BFX94A46060</b> Ⓢ		460VAC	1	0.185
<b>BFX94A57560</b> Ⓢ		575VAC	1	0.185

Ⓢ Four-terminal coil.

### Operational characteristics for BFX91A, BFX92A, BFX93A and BFX94A coils

AC control

Rated voltage at 50/60, 60Hz	V	12...600				
Operating voltage limits						
50/60Hz coil powered at	50Hz pick-up	% Us 80...110				
	50Hz drop-out	% Us 20...55				
	60Hz pick-up	% Us 85...110				
	60Hz drop-out	% Us 20...55				
60Hz coil powered at 60Hz	pick-up	% Us 80...110				
	drop-out	% Us 20...55				
Average coil consumption at ≤20°C						
50/60Hz coil powered at	50Hz in-rush	VA	BFX91 75	BFX92 210	BFX94 300	
		VA	9	15	20	
	60Hz in-rush	VA	70	195	275	
		VA	6.5	13	17	
	60Hz in-rush	VA	75	210	300	
		VA	9	15	20	
Dissipation at 50Hz			W	2.5	5	6.5

### Materials

Class F enamelled copper wire.

### Special versions

For coils with non standard voltages, consult Technical support for information; see contact details on inside front cover.

## 2 Contactors

Spare parts for BF series contactors

### AC/DC and DC coils

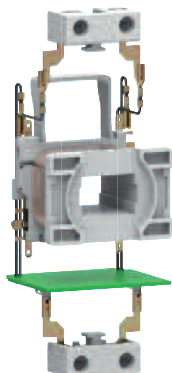

BFX93E...

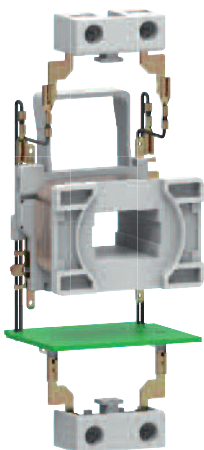

BFX94E...

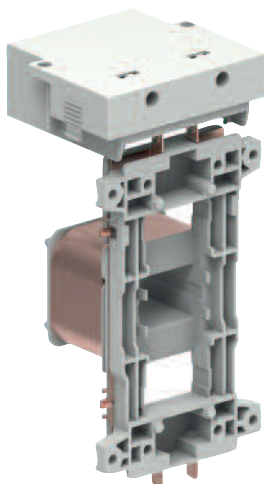

BFX95E...

**new**

Order code	Rated voltage	Qty per pkg	Wt
	[V]	n°	[kg]
For contactors BF40E-BF50E-BF65E-BF80E-BF94E❶.			
<b>BFX93E024❷</b>	20...48V AC/DC	1	0.190
<b>BFX93E110❷</b>	60...110V AC/DC	1	0.190
<b>BFX93E230❷</b>	100...250V AC/DC	1	0.190
For contactors BF95E-BF115E-BF150E.			
<b>BFX94E024❷</b>	20...48V AC/DC	1	0.225
<b>BFX94E110❷</b>	60...110V AC/DC	1	0.225
<b>BFX94E230❷</b>	100...250V AC/DC	1	0.225
For contactors BF160E-BF195E-BF230E.			
<b>BFX95E024</b>	24...60VAC / 20...60VDC	1	0,400
<b>BFX95E110</b>	48...130VAC/DC	1	0,400
<b>BFX95E230</b>	100...250VAC/DC	1	0,400
<b>BFX95E400</b>	250...500VAC/DC	1	0,400

**NOTE: no coil replacement for contactors BF00 D, BF09D-BF38D, BF00L, BF09L-BF38L is possible.**

- ❶ For BF80T2E... contactors the coil supply voltage must be AC or smoothed DC. For pulsating DC please consult our Technical support.
- ❷ Four-terminal coil.

### Operational characteristics for BFX93E coil

AC/DC control			
Rated voltage		V	20...250
Operating voltage limits:	pick-up	% Us	80...110❶
	drop-out	% Us	20...25❷
50/60 Hz coil powered at or in DC			
Average coil cons. at ≤20°C	in-rush	W	45...75
	holding	W	1.2...2.1

### Operational characteristics for BFX94E...

AC/DC control			
Rated voltage		V	20...250
Operating voltage limits:	pick-up	% Us	80...110❶
	drop-out	% Us	20...25❷
50/60 Hz coil powered at or in DC			
Average coil cons. at ≤20°C	in-rush	W	65...110
	holding	W	1.8...3

### Operational characteristics for BFX95E...

AC/DC control			
Rated voltage		V	20...250
Operating voltage limits:	pick-up	% Us	80...110❶
	drop-out	% Us	20...25❷
50/60 Hz coil powered at or in DC			
Average coil cons. at ≤20°C	in-rush	W	160...230
	holding	W	1.5...3

- ❶ For electronically controlled AC/DC coils 80% of Us min. and 110% of Us max.
- ❷ For electronically controlled AC/DC coils 20% of Us min. and 55% of Us max.

### Materials

Class F enamelled copper wire.

### Special versions

For coils with non standard voltages, consult Technical support for information; see contact details on inside front cover.





## 2 Contactors

Spare parts for B series contactors

### AC/DC coils



Coil



Bridge rectifier



Coil protection



Coil assembly

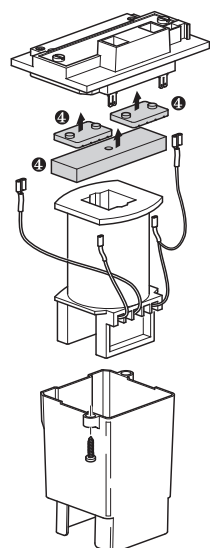

Order code	Rated voltage AC 50/60Hz and DC	Qty per pkg	Wt
	[V]	n°	[kg]

Coil for B250-B310-B400 contactors.

<b>11BA169924</b>	24VAC/DC	1	1.800
<b>11BA169948</b>	48VAC/DC	1	1.800
<b>11BA169960</b>	60VAC/DC	1	1.800
<b>11BA1699110</b>	110...125VAC/DC	1	1.800
<b>11BA1699220</b>	220...240VAC/DC	1	1.800
<b>11BA1699380</b>	380...415VAC/DC	1	1.800
<b>11BA1699440</b>	440...480VAC/DC	1	1.800

Coil for B500-B630-B630 1000 contactors.

<b>11BA180048</b>	48VAC/DC	1	3.400
<b>11BA180060</b>	60VAC/DC	1	3.400
<b>11BA1800110</b>	110...125VAC/DC	1	3.400
<b>11BA1800220</b>	220...240VAC/DC	1	3.400
<b>11BA1800380</b>	380...415VAC/DC	1	3.400
<b>11BA1800440</b>	440...480VAC/DC	1	3.400

Coil for B1250-B1600 contactors.

<b>11BA1800110</b> Ⓢ	110...125VACⓈ	1	3.400
<b>11BA1800220</b> Ⓢ	220...240VACⓈ	1	3.400

Order code	For contactor	Qty per pkg	Wt
		n°	[kg]

Bridge rectifier (Faston terminals).

<b>11BA17001</b> Ⓢ	B250-B310-B400	1	0.230
<b>11BA1799</b> Ⓢ	B500-B630-B6301000 B1250-B1600	1	0.520

Coil protection.

<b>11BA1678</b>	B250-B310-B400	1	0.079
<b>11BA1803</b>	B500-B630-B6301000 B1250-B1600	1	0.164

Coil assembly  
(Coil, rectifier and coil protection).

<b>11BA1671</b> Ⓢ	B250-B310-B400	1	2.290
<b>11BA1796</b> Ⓢ	B500-B630-B630 1000 B1250-B1600	1	4.650

Ⓢ Available for AC supply only.

② Add the coil voltage digit. Standard voltages are:  
- AC/DC 24 - 48 - 60 - 110...125 (indicate 110) - 220...240 (indicate 220) - 380...415 (indicate 380) - 440...480V (indicate 440).

Example: 11BA1671110 for B250...B400 contactor coil assembly suitable for 110-125VAC/DC supply.

③ Add the coil voltage digit. Standard voltages are:  
- AC/DC 48 - 60 - 110...125 - 220...240 - 380...415 - 440...480V.

Example: 11 BA1796 110 for B500-B1600 contactor coil assembly suitable for 110-125VAC/DC supply.

For B1250 and B1600 only 110...125 and 220...240VAC voltages are available.

④ When replacing the coil, retrieve the dampers (1 pair for B250...B400 and 2 pairs for B500...B1600) and the fixed core and refit them with the new coil.

⑤ For contactors with coil voltage up to 415V. For higher voltages add suffix 440 to the code. E.G.: 11BA17001440.

### Operational characteristics

AC and DC control

For contactor type		B250 - B310 - B400
Supply voltage		AC and DC
Rated control voltage	V	24...480
Operating limits	pick-up	% Us 80...110
	drop-out	% Us 20...60
Consumption	in-rush	VA/W 300
	holding	VA/W 10
Dissipation	W	10

For contactor type		B500 - B630 - B630 1000
Supply voltage		AC and DC
Rated control voltage	V	48...480
Operating limits	pick-up	% Us 80...110
	drop-out	% Us 20...60
Consumption	in-rush	VA/W 400
	holding	VA/W 18
Dissipation	W	18

For contactor type		B1250 - B1600
Supply voltage		AC
Rated control voltage	V	110/240
Operating limits	pick-up	% Us 80...110
	drop-out	% Us 20...60
Consumption	in-rush	VA/W 800
	holding	VA/W 45
Dissipation	W	40

### Materials

Class F enamelled copper wire.

### Coil assembly

Comprises the coil, bridge rectifier, fixed core, coil protection, cross piece and fixing screws.

### Special versions

For coils with non standard voltages, consult Technical support for information; see contact details on inside front cover.

## 2 Contactors

Spare parts for B series contactors

### Main contacts for BF contactors



BFX99...

Order code	For contactor	Qty per pkg	Wt
		n°	[kg]

Main contacts.  
3 or 4 pole set complete with screws.

BFX99026T	BF2600	1	0.038
BFX99026F	BF26T4	1	0.051
BFX99032T	BF3200	1	0.070
BFX99038T	BF3800	1	0.070
BFX99038F	BF38T4	1	0.093
BFX99040T	BF4000	1	0.095
BFX99040F	BF40T4	1	0.127
BFX99050T	BF5000	1	0.095
BFX99050F	BF50T4	1	0.127
BFX99065T	BF6500	1	0.095
BFX99065F	BF65T4	1	0.127
BFX99080T	BF8000	1	0.100
BFX99080F	BF80T4	1	0.130
BFX99094T	BF9400	1	0.100
BFX99095T	BF9500	1	0.210
BFX99095F	BF95T4	1	0.280
BFX99115T	BF11500	1	0.225
BFX99115F	BF115T4	1	0.300
BFX99150T	BF15000	1	0.225
BFX99150F	BF150T4	1	0.300
BFX99160T	BF160	1	0.350
BFX99160F	BF160T4	1	0.450
BFX99195T	BF195	1	0.350
BFX99195F	BF195T4	1	0.450
BFX99230T	BF230	1	0.350
BFX99230F	BF230T4	1	0.450

new

### Main contacts and arc chutes for B contactors

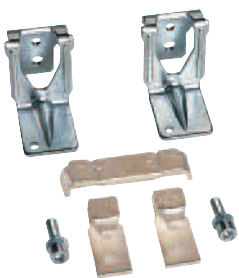

11G383... - 11G384... - 11G385...  
11G525... - 11G526... - 11G537...

Order code	For contactor	Qty per pkg	Wt
		n°	[kg]

Main contacts.  
3 or 4 pole set complete with Allen screws and key for contact replacement.

11G383	B250	1	0.770
11G3834	B2504	1	1.030
11G385	B310	1	0.770
11G3854	B3104	1	1.030
11G384	B400	1	0.770
11G3844	B4004	1	1.030
11G525	B500	1	2.520
11G5254	B5004	1	3.360
11G526	B630	1	2.660
11G5264	B6304	1	3.550
11G537	B6301000	1	2.660
11G5374	B63010004	1	3.550
11G538	B125024	1	5.040
11G5384	B1250424	1	6.720
11G539	B160024	1	5.320
11G5394	B1600424	1	7.100

Arc chutes.

BFX9805T	BF16000-BF19500-BF23000	1	1.000
BFX9805F	BF160T4-BF195T4-BF230T4	1	1.200
11BA1713	B250-B310-B400	1	1.210
11BA1714	B2504-B3104-B4004	1	1.600
11BA1838	B500-B630-B6301000	1	1.910
11BA1839	B5004-B6304-B63010004	1	2.490

new



Arc chute 11BA...

### Special versions

For non standard spare contact configurations, contact Technical support; see contact details on inside front cover.

NOTE: For B1250 and B1600 contactor spares, consult Technical support for information; see contact details on inside front cover.





## 2 Contactors

Dimensions [mm (in)]

### BG... MINI-CONTACTORS WITH AC OR DC SUPPLY VOLTAGE

**BG... three poles with screw terminals and RF...9 thermal overload relay**

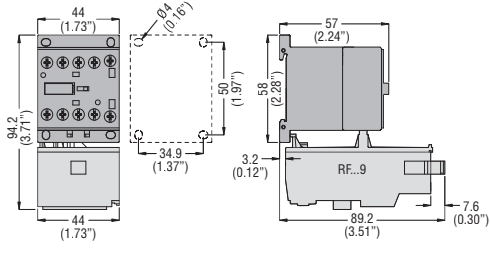

**BG...T... four poles, with screw terminals**

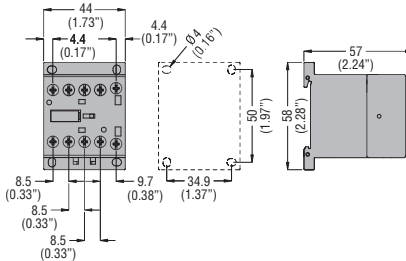

**BGP... with rear PCB solder pins**

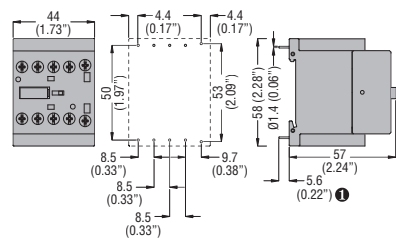

**BGF... with Faston terminals**

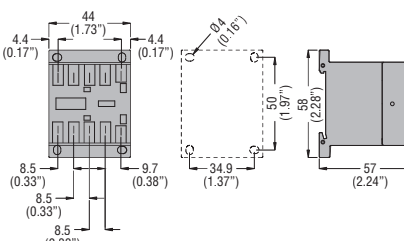

① Recommended PCB drillings 1.7-2mm.

### BF... CONTACTORS WITH AC SUPPLY VOLTAGE

**BF00A... BF09 A... - BF12A... - BF18A... - BF25A... three poles with RF...38 thermal overload relay**

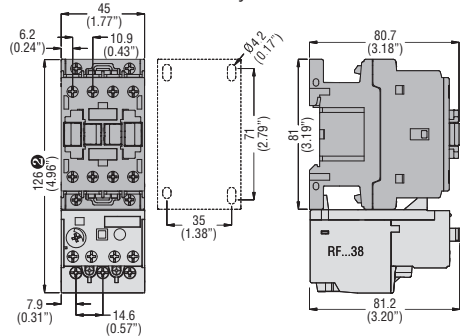

② 135mm/5.31" for RFE45

**BF09T...A... - BF12T...A... - BF18T...A... four poles**

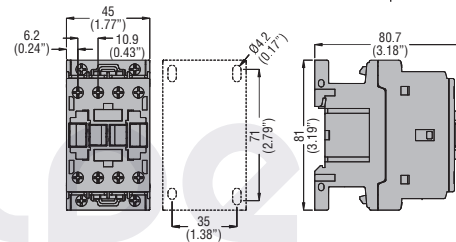

**BF2600A... - BF3200A... - BF3800A... three poles with RF...38 thermal overload relay**

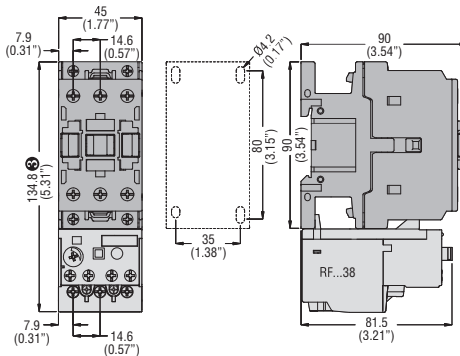

③ 144mm/5.67" for RFE45

**BF26T...A... - BF38T...A... four poles**

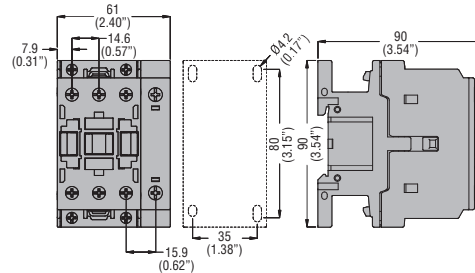

**BF4000A... - BF5000A... - BF6500A... - BF8000A... - BF9400A... three poles with RF82 thermal overload relay**

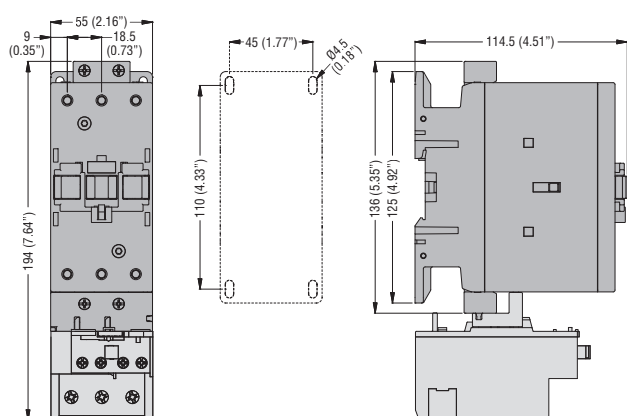

**BF40T4...A... - BF50T4...A... - BF65T4...A... - BF80T4...A... - BFD80T4... - BF80T2A... four poles**

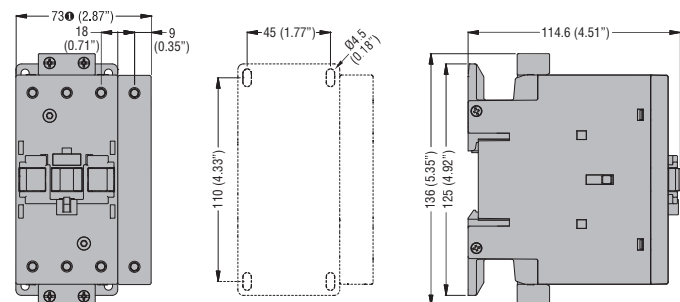

① BF80T2 91mm/3.58", BFD6500... - BFD8000... 55mm/2.16"



## 2 Contactors

Dimensions [mm (in)]

**BF9500A... - BF11500A... - BF15000A...** three poles with **RF110** thermal relay

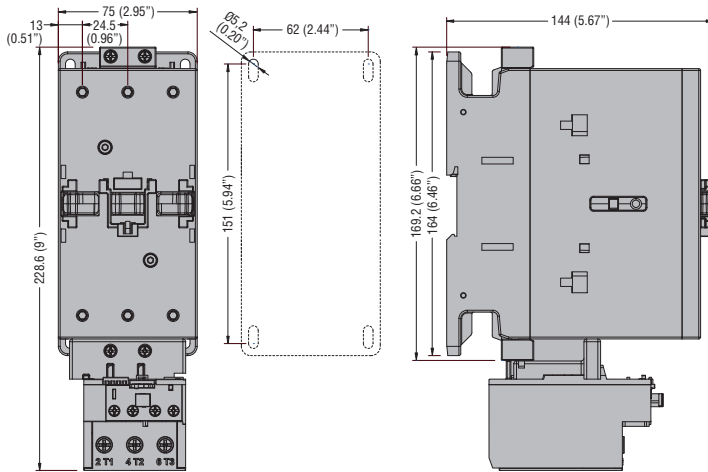

**BF95T4A... - BF115T4A... - BF150T4A...** four poles

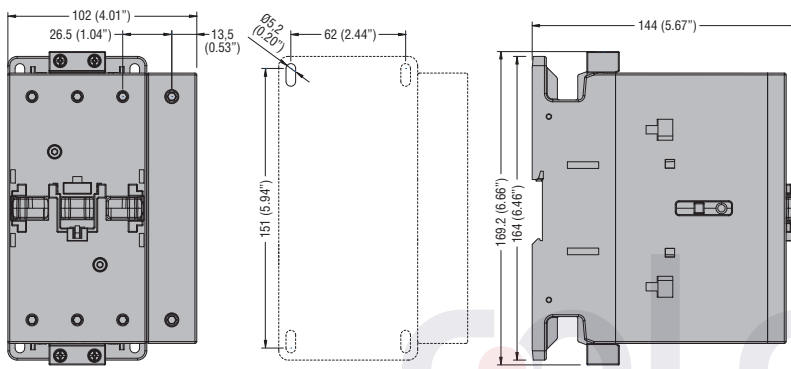

**BF...CONTACTORS WITH DC SUPPLY VOLTAGE**

**BF00...D and BF00...L - BF09... - BF12... - BF18... - BF25...D and L** three poles with **RF...38** thermal overload relay

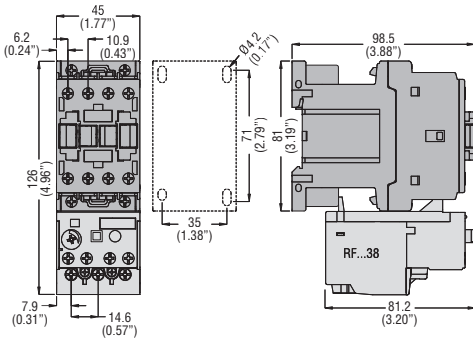

Control relays

**BF00...D and BF00...L**  
**BF09T... - BF18T... D and L** four poles

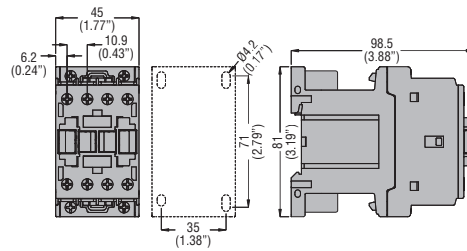

**BF26... - BF32... - BF38...D and L** three poles with **RF...38** thermal overload relay

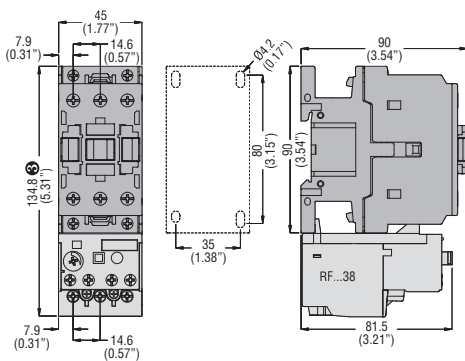

**BF26T... - BF38 T...D and L** four poles

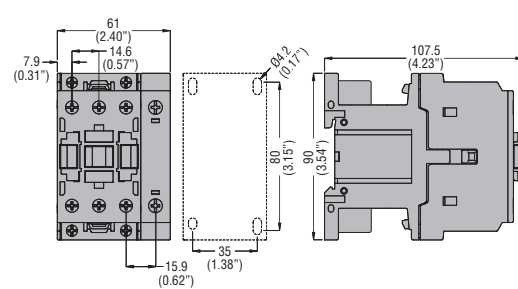



## 2 Contactors

Dimensions [mm (in)]

**BF4000E... - BF5000E... - BF6500E... - BF8000E... - BF9400E...**  
three poles with **RF82** thermal overload relay

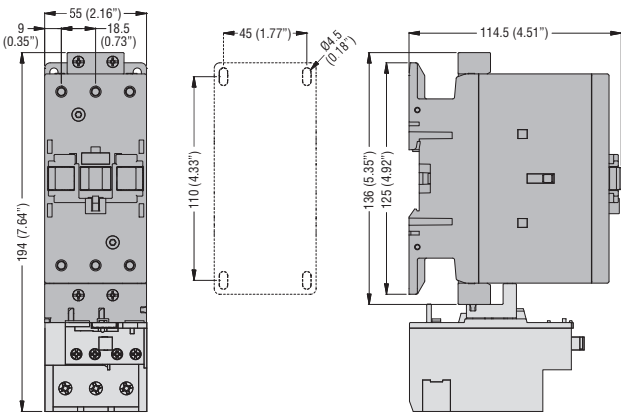

**BF65T4E... - BF80T4E... - BF80T2E...** four poles

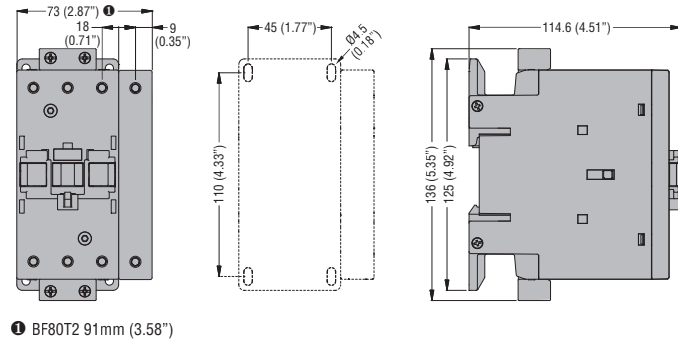

**BF9500E... - BF11500E... - BF15000E...** three poles with **RF110** thermal relay

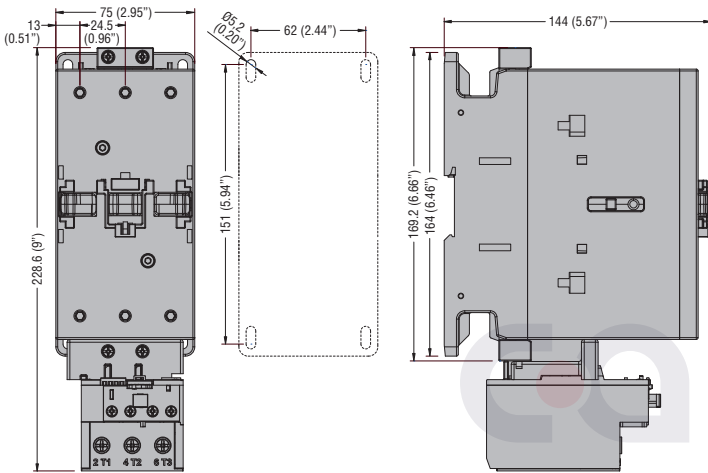

**BF95T4E... - BF115T4E... - BF150T4E... - BFD150T4E...** four poles

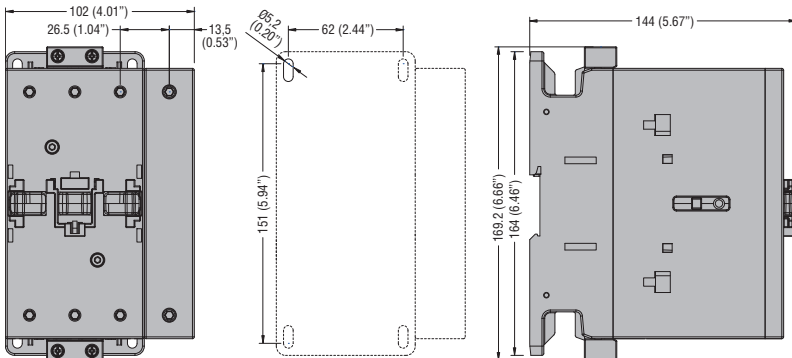

## 2 Contactors

Dimensions [mm (in)]

BF...CONTACTORS WITH AC/DC SUPPLY VOLTAGE

**BF16000E... - BF19500E... - BF23000E...** three poles

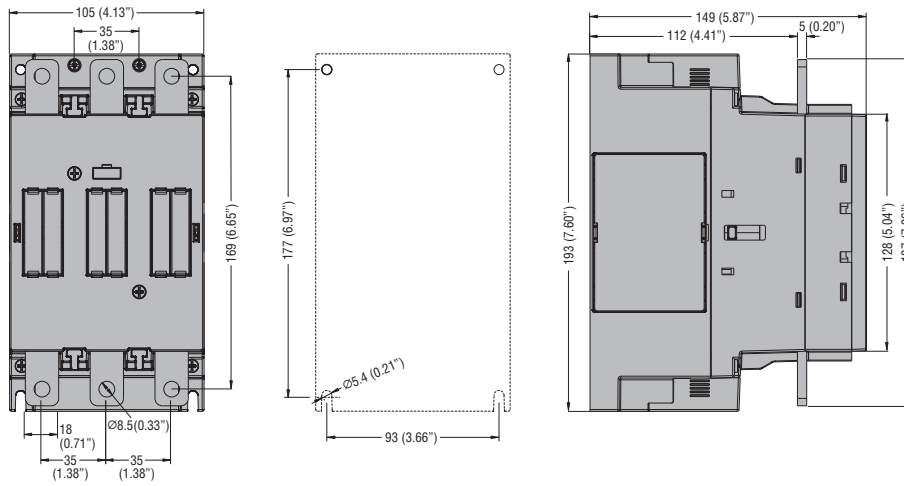

**BF160T4E... - BF195T4E... - BF230T4E... - BFD230T4E...** four poles

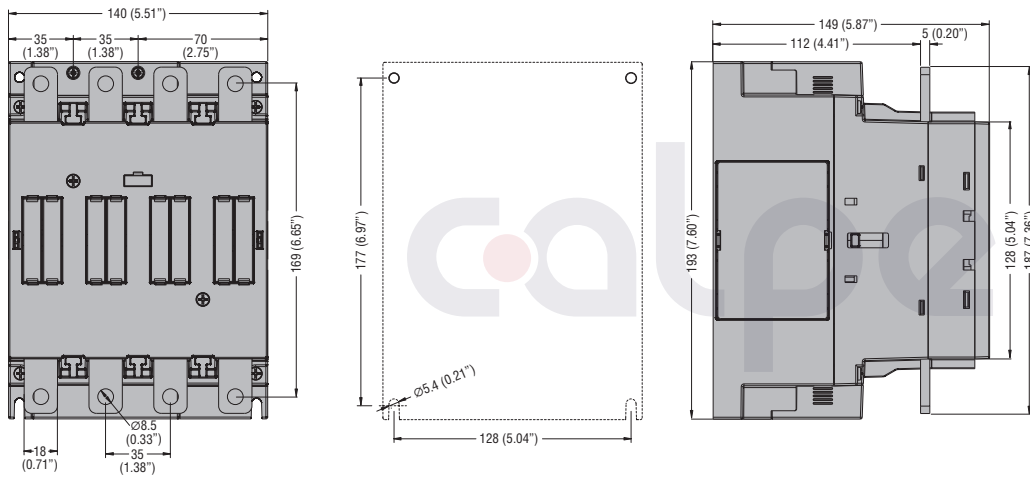



## 2 Contactors

Dimensions [mm (in)]

**B250 - B310 - B400** three poles with **RF...420** thermal overload relay

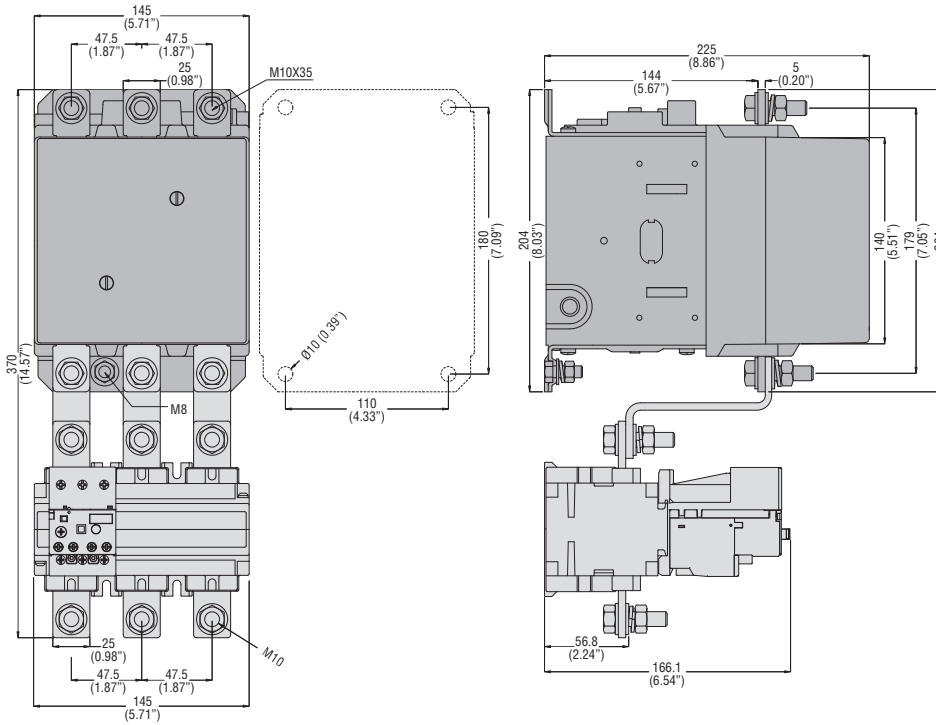

**B2504 - B3104 - B4004** four poles

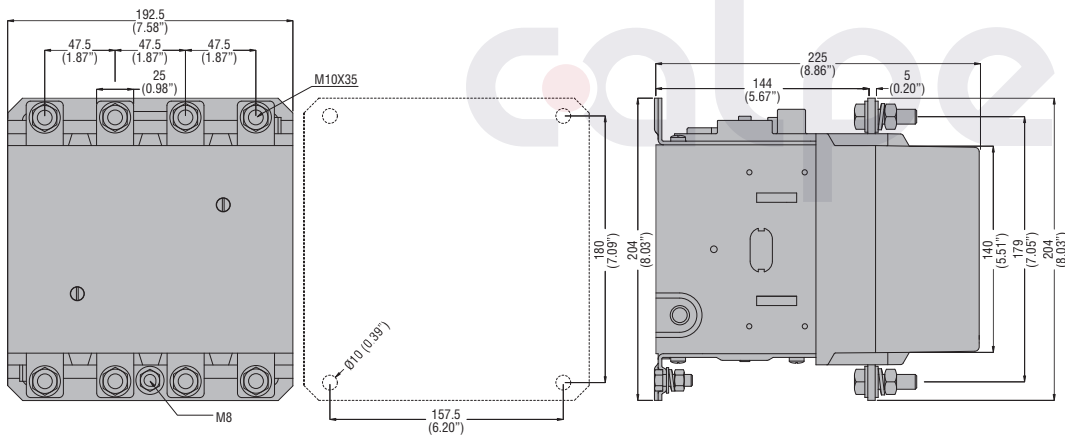

# 2 Contactors

Dimensions [mm (in)]

## B500 - B630 three poles

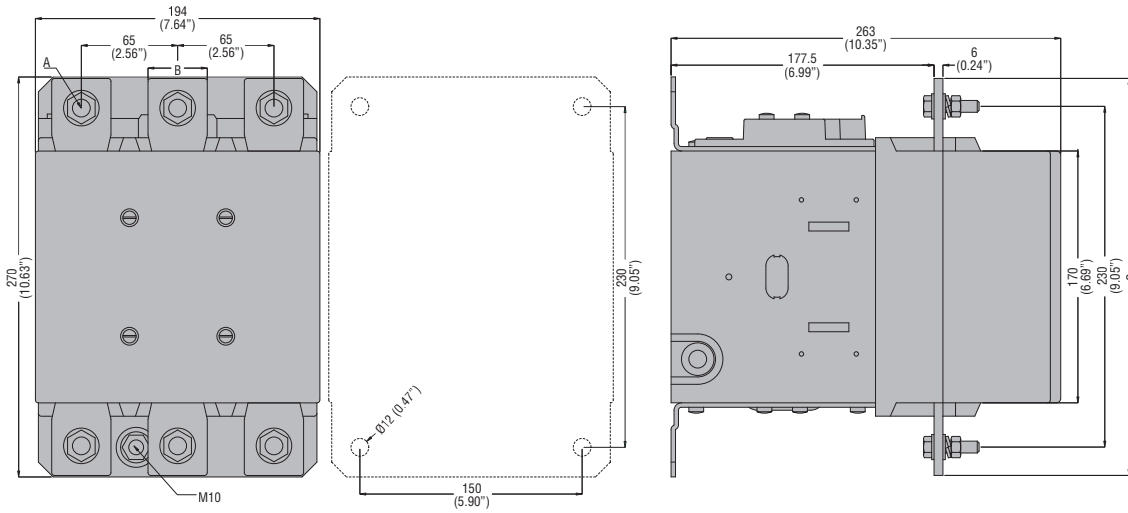

CONTACTOR TYPE	A	B	C
B500	M10 35 (1.38")	265 (10.43")	
B630	M12 40 (1.57")	270 (10.63")	

## B5004 - B6304 four poles

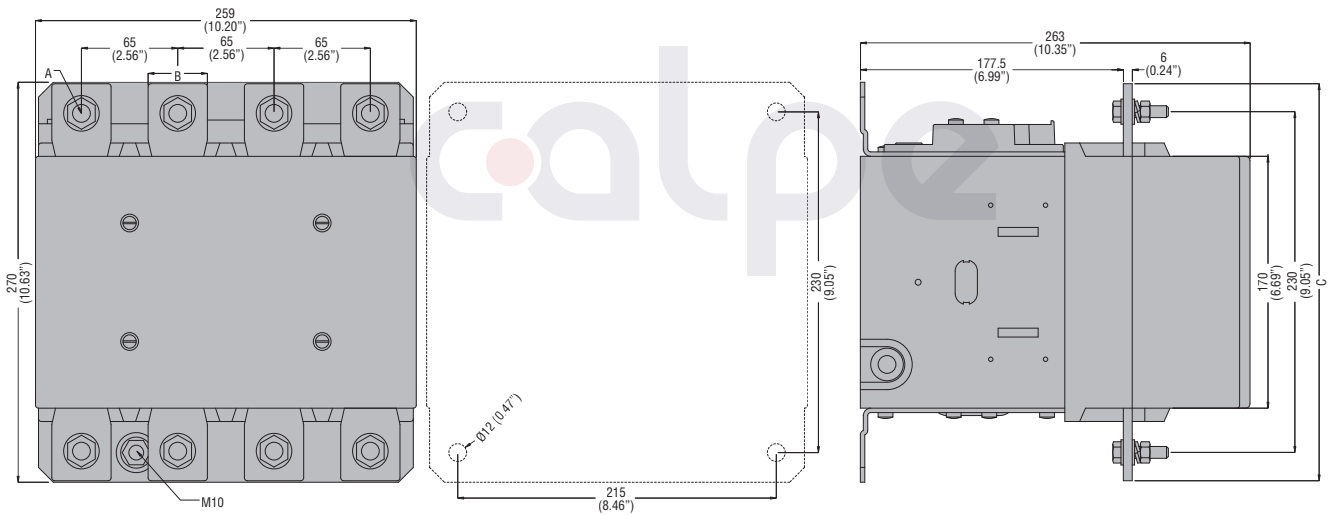

CONTACTOR TYPE	A	B	C
B500	M10 35 (1.38")	265 (10.43")	
B630	M12 40 (1.57")	270 (10.63")	



## 2 Contactors

Dimensions [mm (in)]

**B6301000** three poles

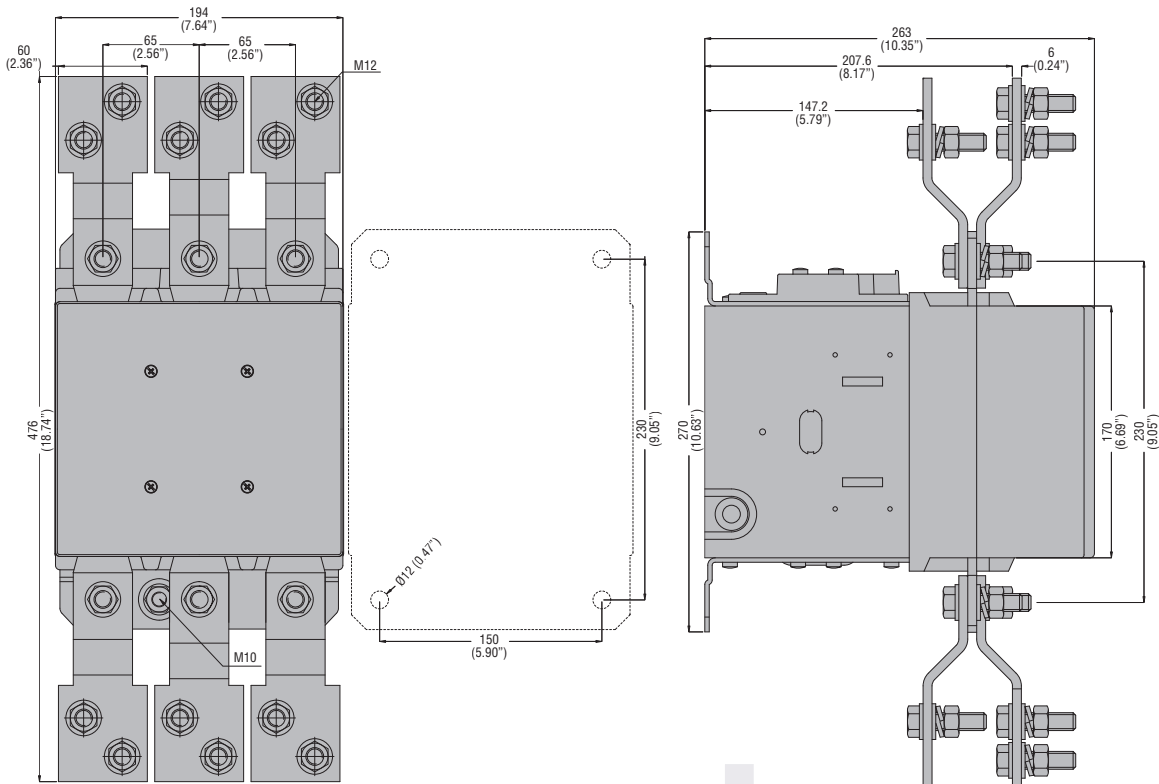

**B63010004** four poles

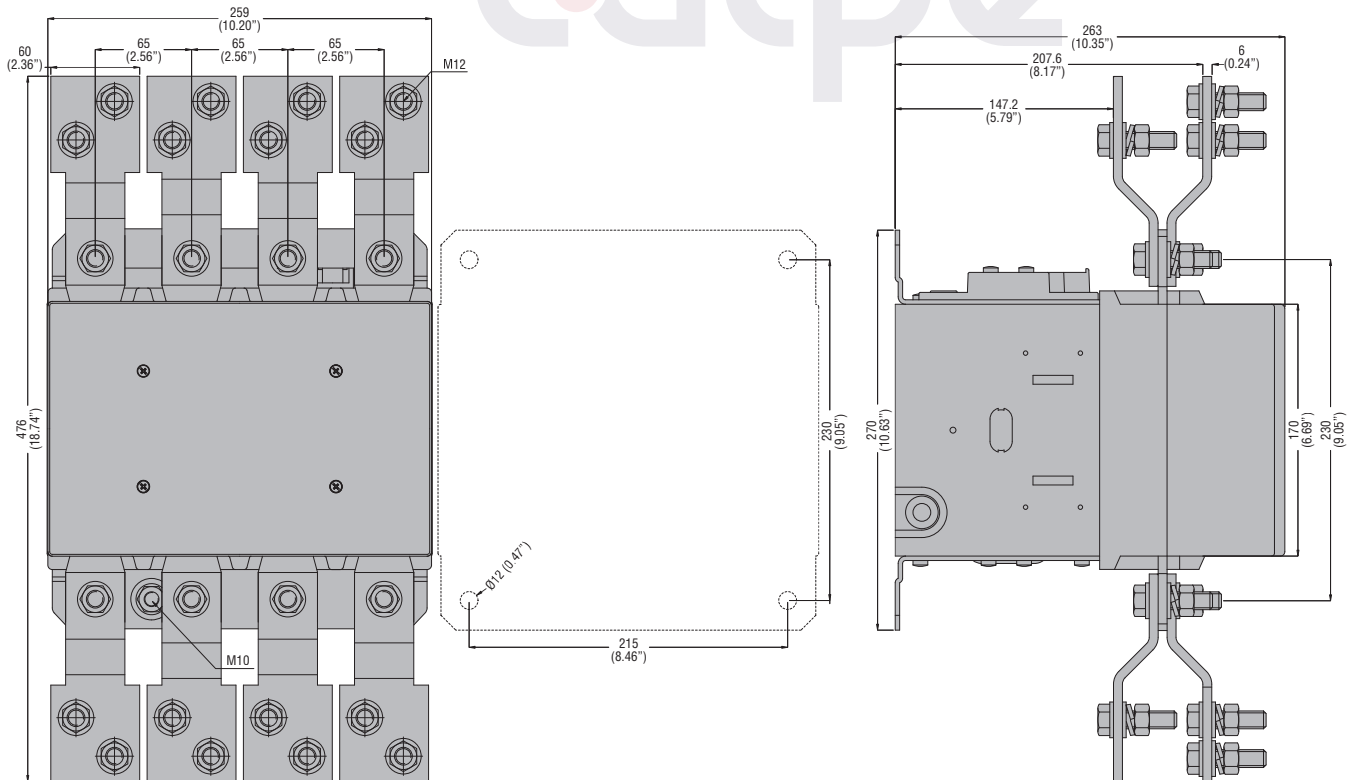



## 2 Contactors

Dimensions [mm (in)]

### B1250 - B1600 three poles

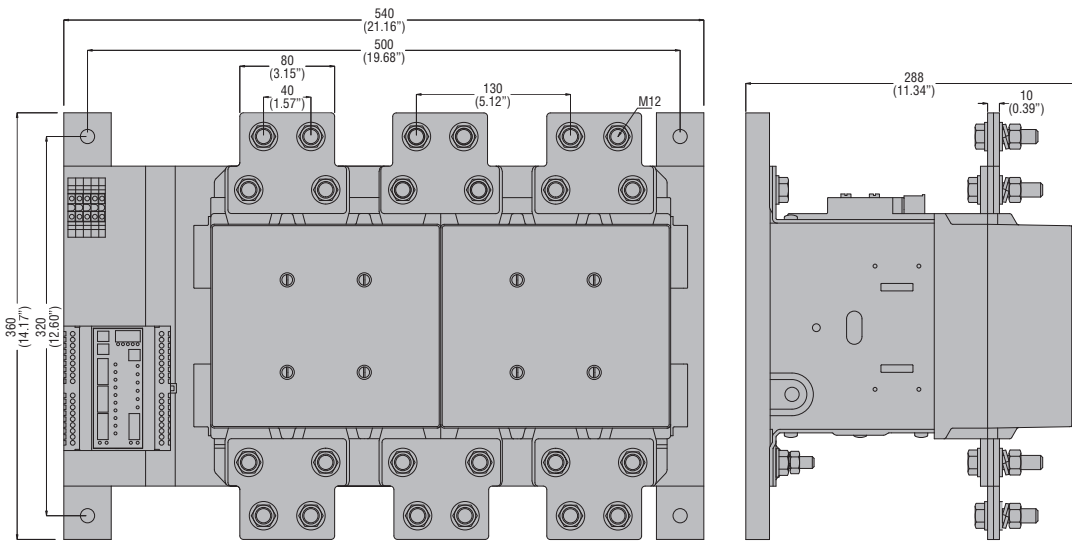

### B12504 - B1600 four poles

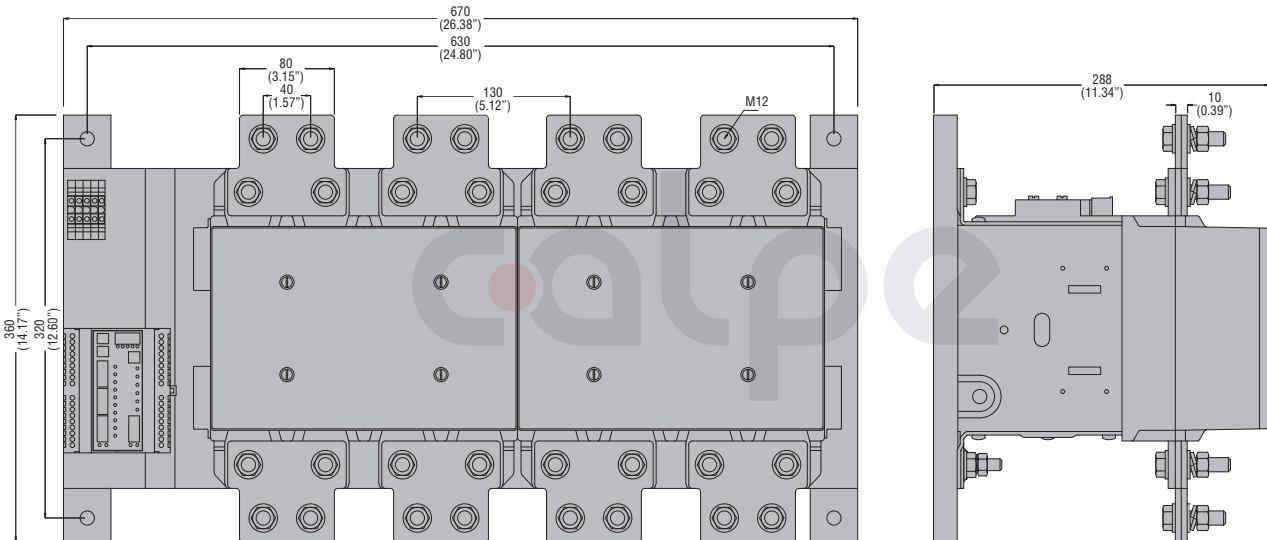

### B250 - B310 - B400 - B500 - B630 - B6301000 - B1250 - B1600

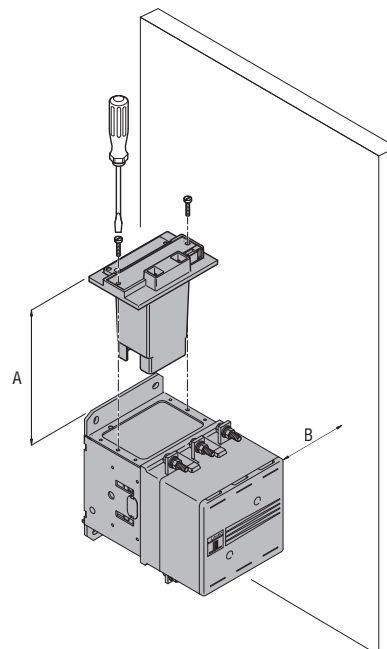
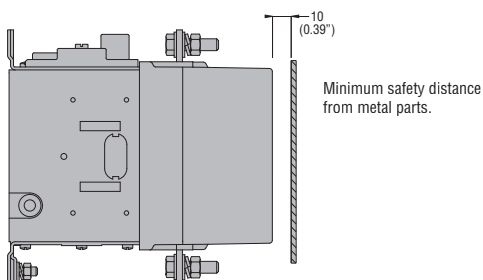

Minimum space needed to replace the coil.

	B250-B310-B400	B500-B630 1000
A	145 (5.71")	170 (6.69")
B	110 (4.33")	160 (6.30")

If dimension B is respected, coil replacement is possible without removing power wiring.





## 2 Contactors

Dimensions [mm (in)]

### CONTACTORS FOR POWER FACTOR CORRECTION

#### BFK0910A - BFK1210A - BFK1810A

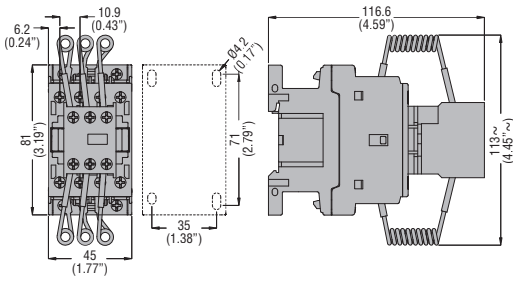

#### BFK2600A - BFK3200A - BFK3800A

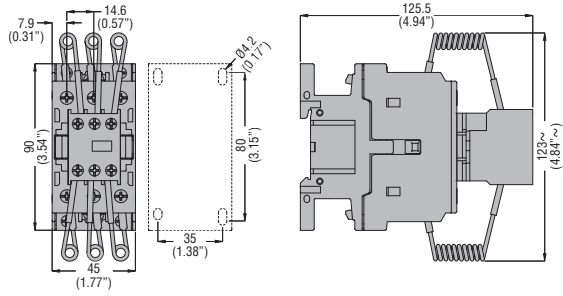

#### BFK50 - BFK65 - BFK80 - BFK94

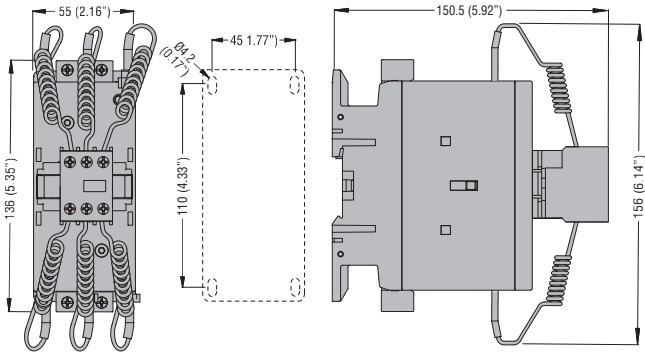

#### BFK95 - BFK115 - BFK150

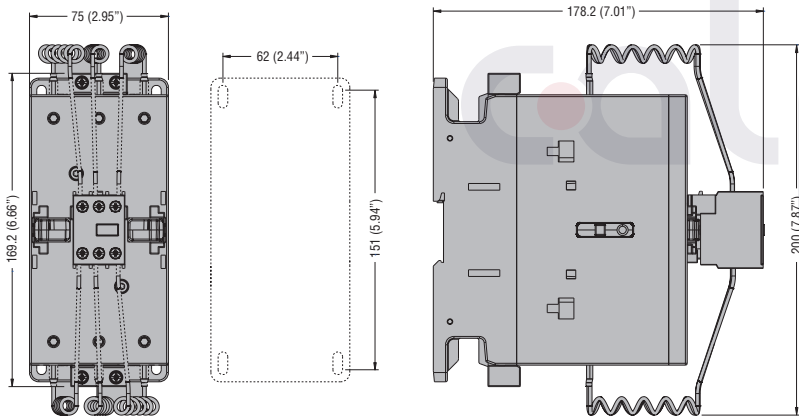

### ADD-ON BLOCKS WITH BG MINI-CONTACTORS

#### BGX10... - BGF10... auxiliary contacts

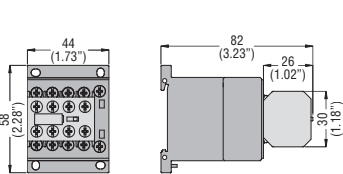

Valid for BGX11... contacts as well when mounted on left-hand contactor of BGT or BGC assembly (p. 4-5).

#### BGX5000 interlock with BGX10..., BGF10... contacts and BGX77... or BGX78... or BGX79... suppressor

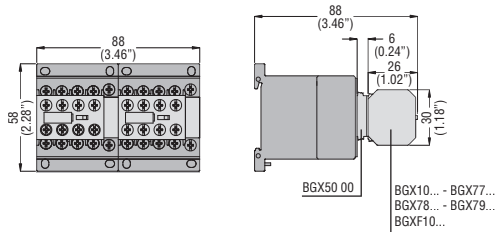

#### BGX77..., BGX78... or BGX79... suppressor only

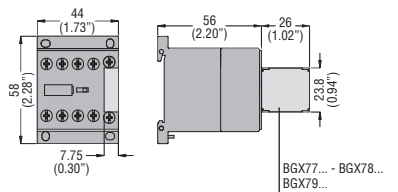

#### BGX8000 shroud

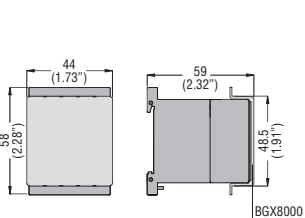

#### Paralleling links G323, G324

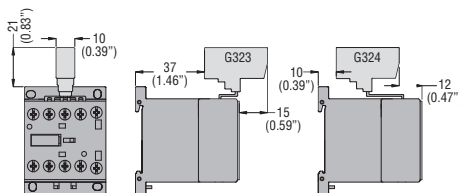

#### G325, G326

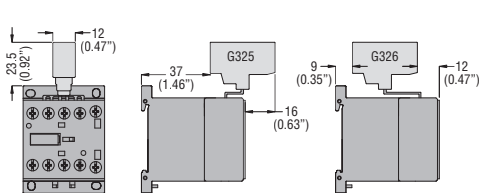



## 2 Contactors

Dimensions [mm (in)]

### ADD-ON BLOCKS WITH BF CONTACTORS

Auxiliary contacts **BFX10...**  
w/2 contacts

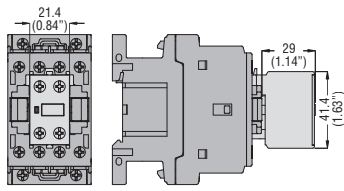

**BFX10...** w/4 contacts

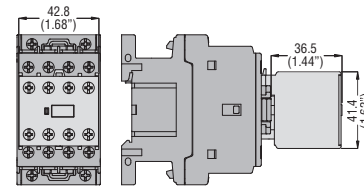

**BFX12...**

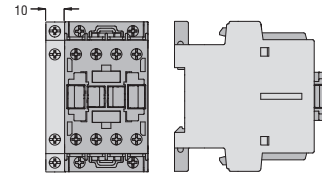

**G484...**

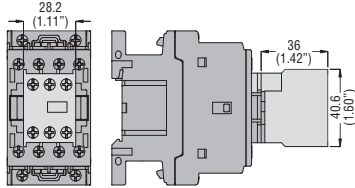

**G418...**

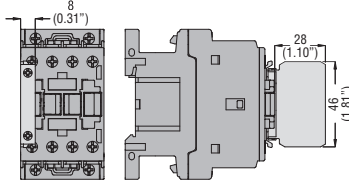

**G218**

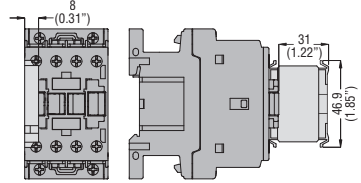

**G481..., G482**

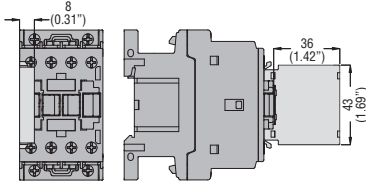

**G280 with G218**

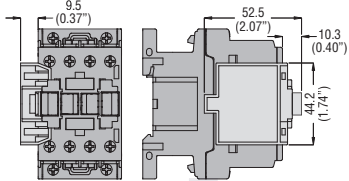

**G419, with G418..., G428..., G483 with G481... or G482**

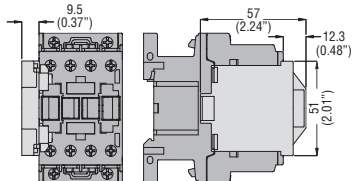

**G485..., G486..., G487 delayed contacts**

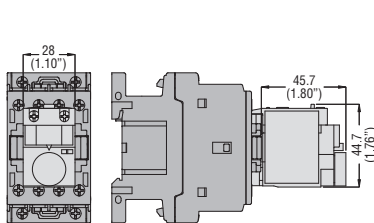

Fourth pole  
**BFX42**

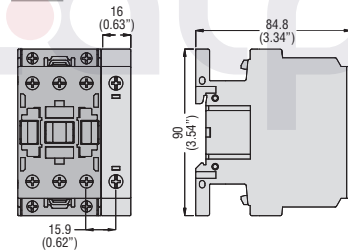

**BFXD42**

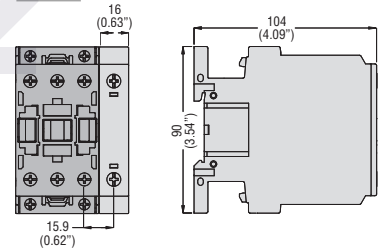

**BFX43**

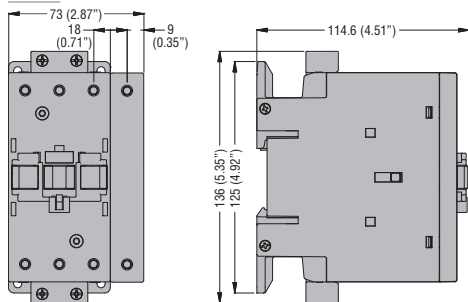

**BFX44**

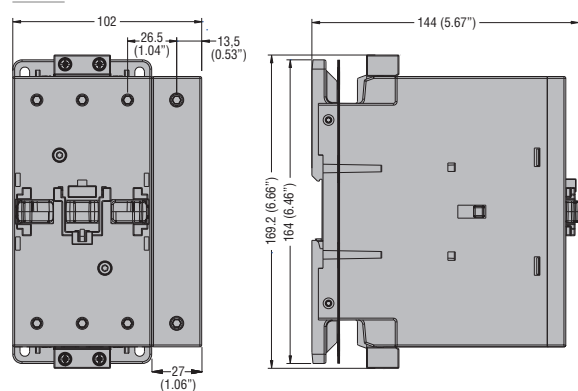

Mechanical interlocks

**BFX5000, BFX5001, BFX5300, BFX5301, BFX5400, BFX5401**

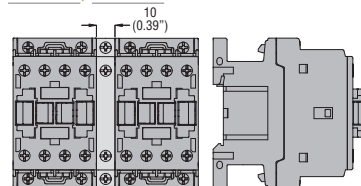

**BFX5002**

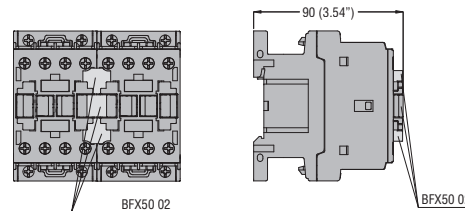

**BFX5003, BFX5303, BFX5403**

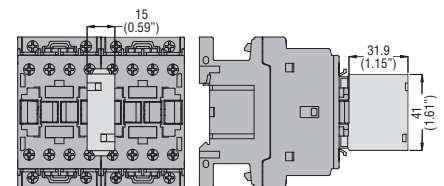



# 2 Contactors

Dimensions [mm (in)]

## Mechanical interlocks

**BFX5303 - BFX5403**

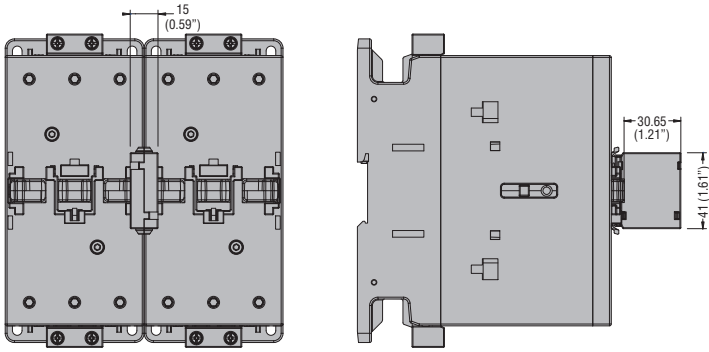

**G222, G272, BFX641** mechanical latch

**G454, G455, BF642** manual closing

**BFX80** sealing cover

Rigid connecting kit  
90mm (3.54") with **BFX5000** and **BFX5001**  
100mm (3.94") with **BFX5002** and **BFX5003**

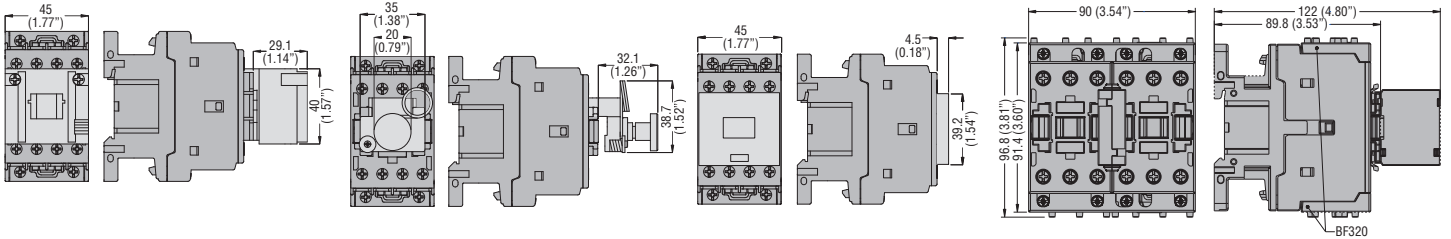

**G231** terminal  
1-pole

**G232** terminal  
1-pole

**BFX8901** fixing base

**BFX8902** fixing brackets

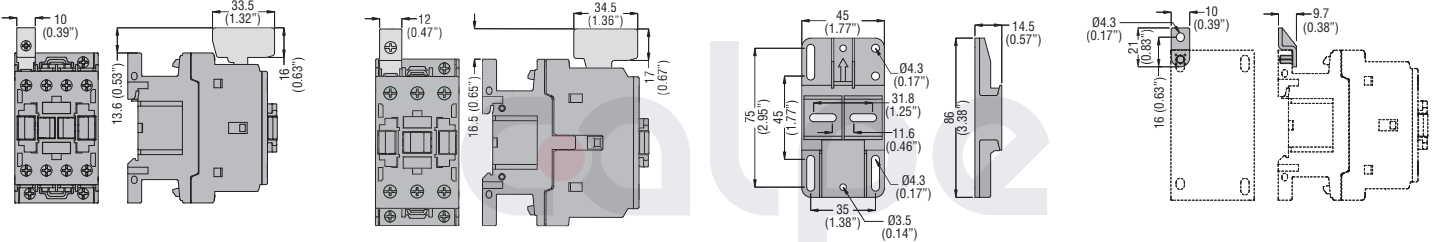

## Rigid connecting kit

**BFX3101**

**BFX3102**

**BFX3201**

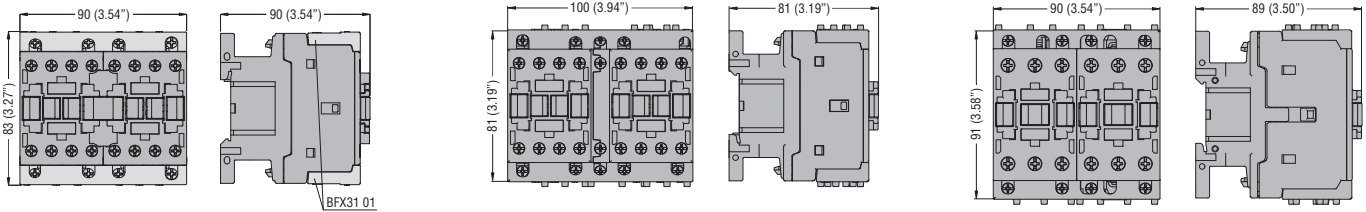

**BFX3301**

**BFX3401**

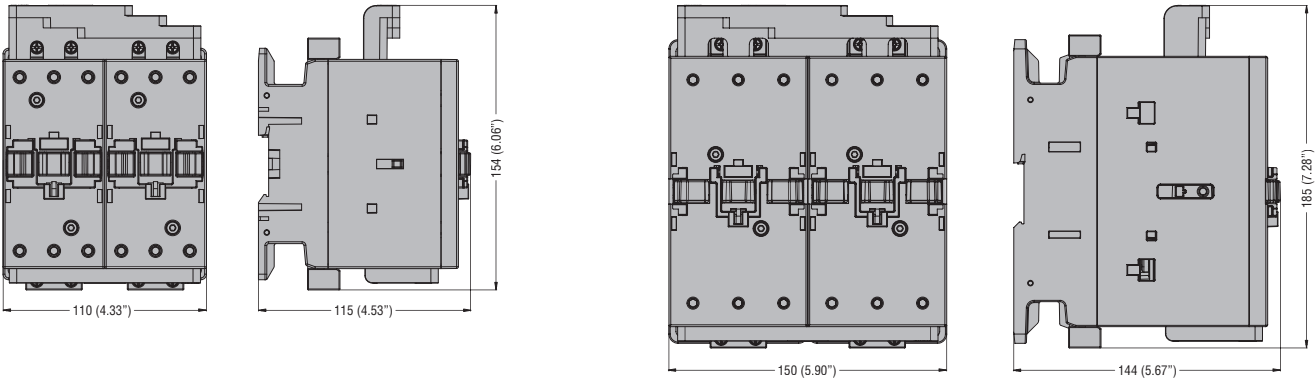

**BFX3131**

**BFX3232**

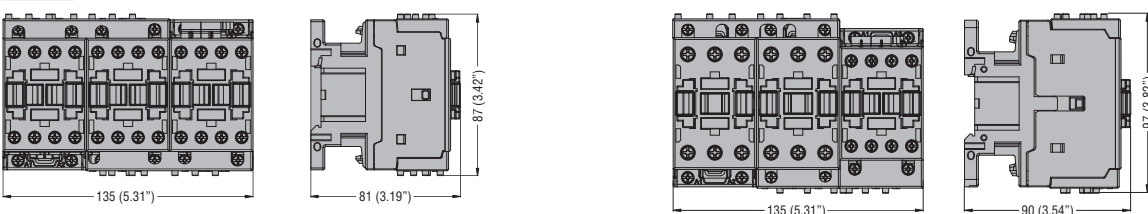

## 2 Contactors

Dimensions [mm (in)]

**BFX3231**

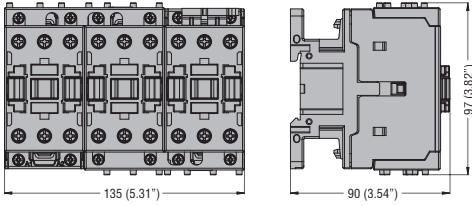

**BFX3332**

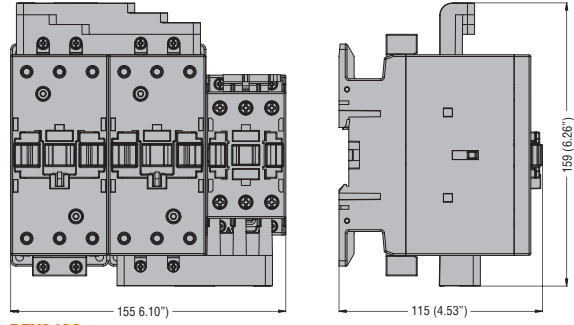

**BFX3331**

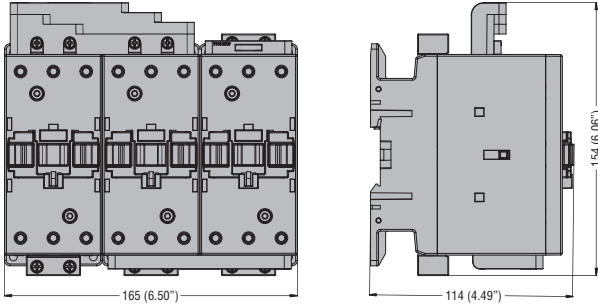

**BFX3432**

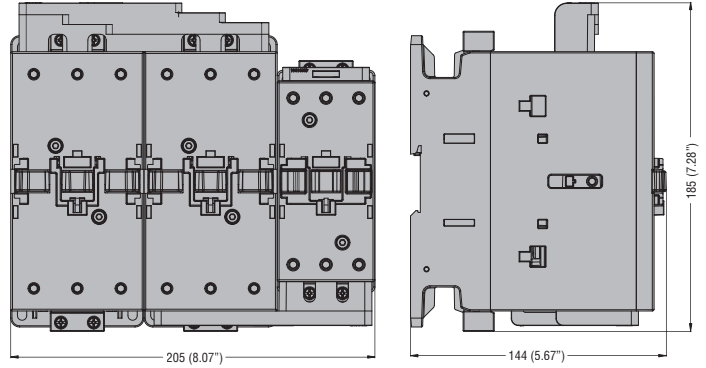

**BFX3431**

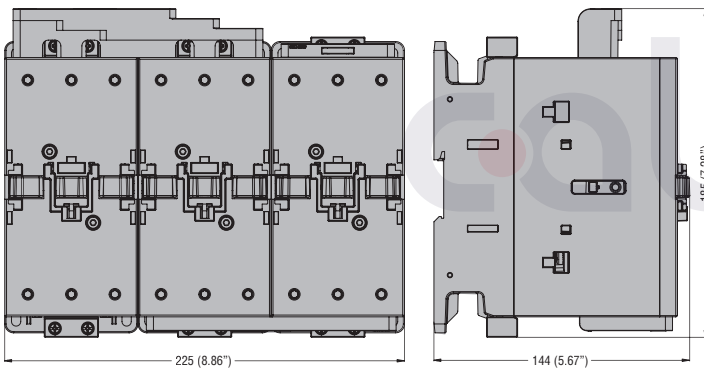

**BFX3361**

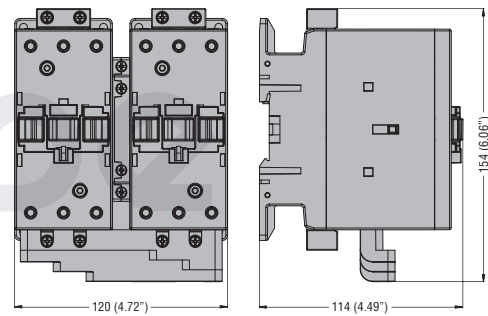

**BFX3461**

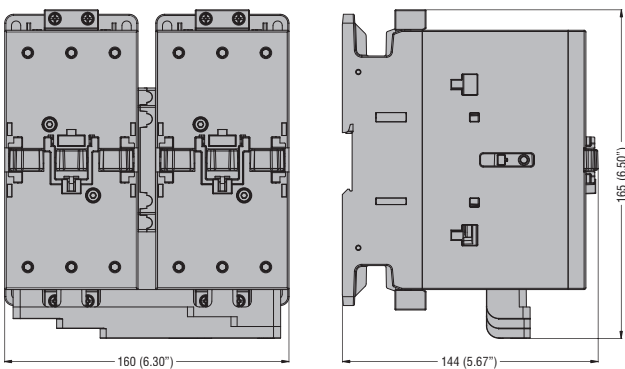

**BFX3371**

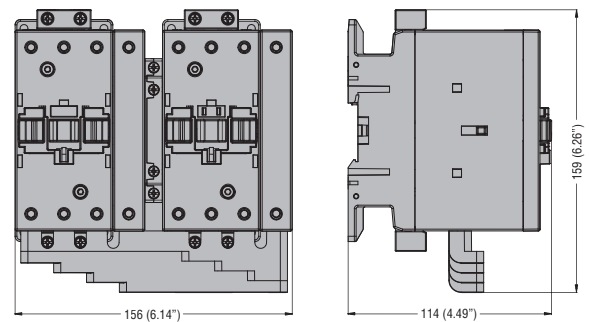

**BFX3471**

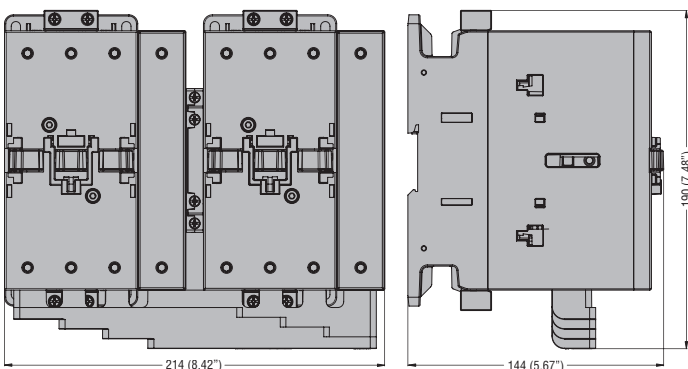





## 2 Contactors

Dimensions [mm (in)]

### ADD-ON BLOCKS WITH BF160...BF230 CONTACTORS

**BFX10C..., BFX12C...** auxiliary contacts

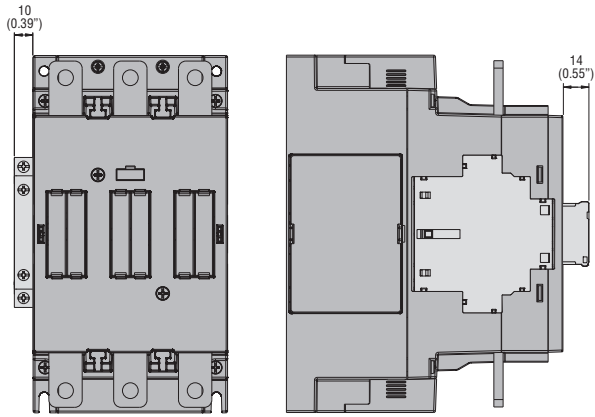

**BFX5500** interlock

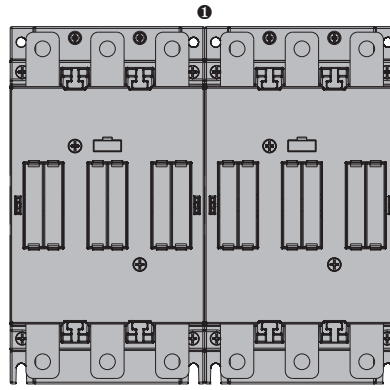

❶ The BFX5500 interlock is mounted inside the 2 contactors without dimensions increasing.

**BFX5503, BFX5504** interlocks

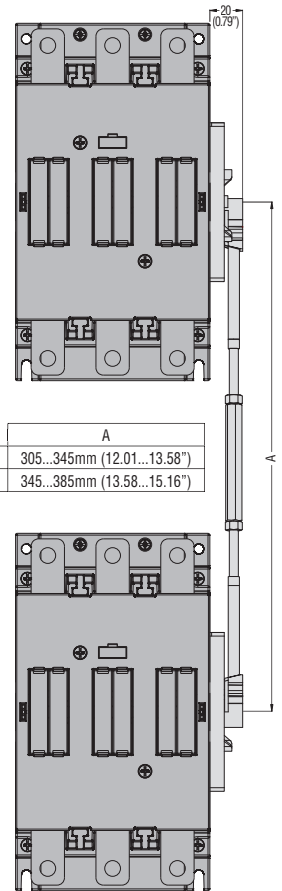

	A
BFX5503	305...345mm (12.01...13.58")
BFX5504	345...385mm (13.58...15.16")

### Terminal protection

**BFX835 - BFX845**

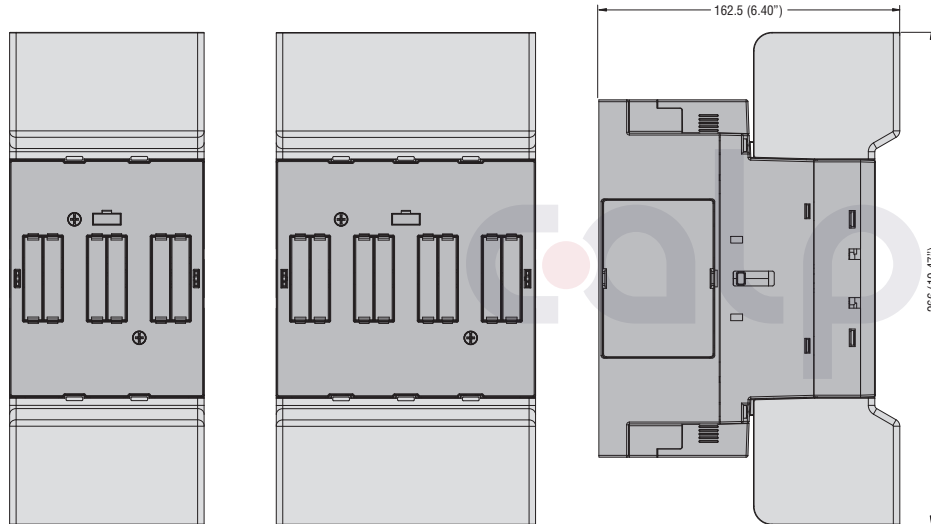

### Phase barrier

**BFX805**

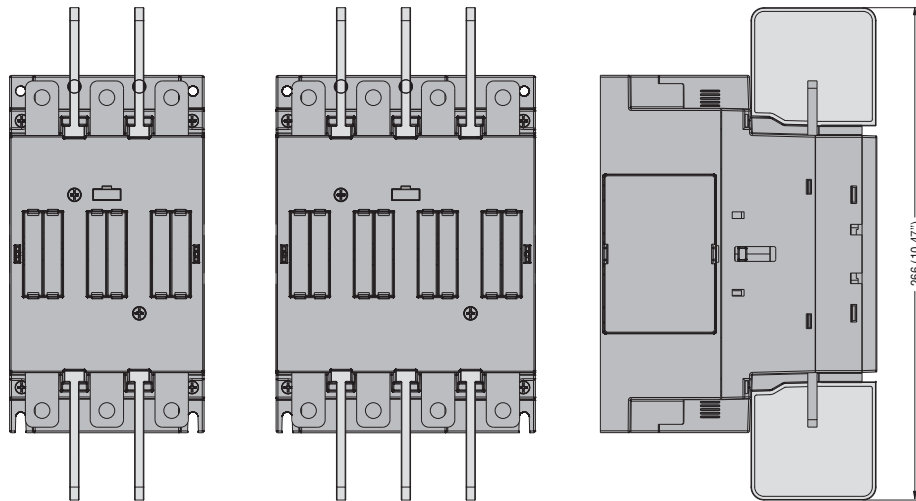



## 2 Contactors

Dimensions [mm (in)]

### ADD-ON BLOCKS WITH B CONTACTORS

Auxiliary contacts **G350, G354**

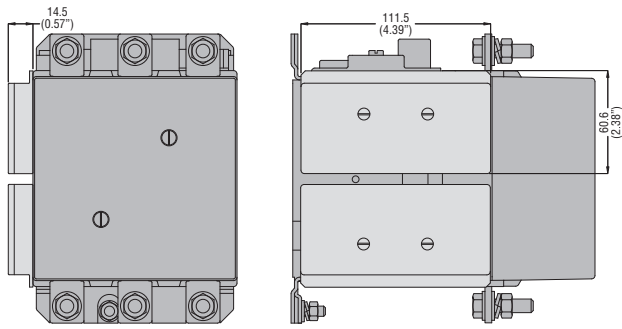

### G358 adapter

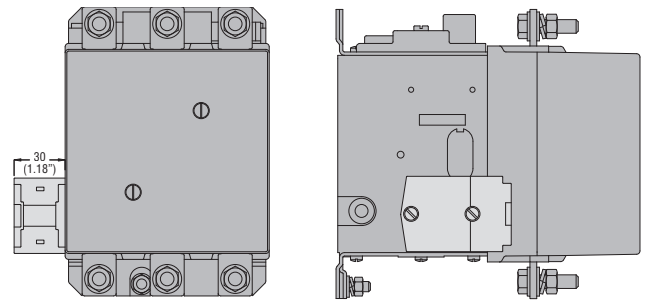

2

### G355 interlocks

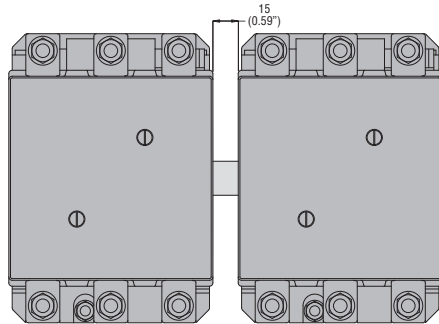

### G356...

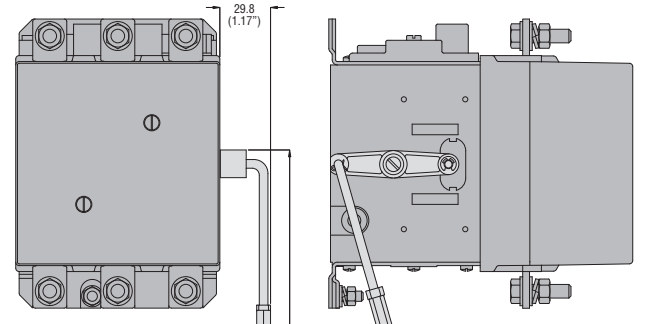

### Terminal protection **G361**

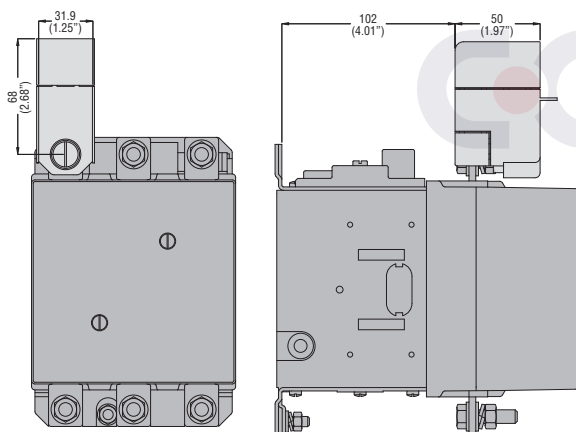

1 For dimensions, refer to page 2-68 to 2-76.

### Terminal protection

#### G363

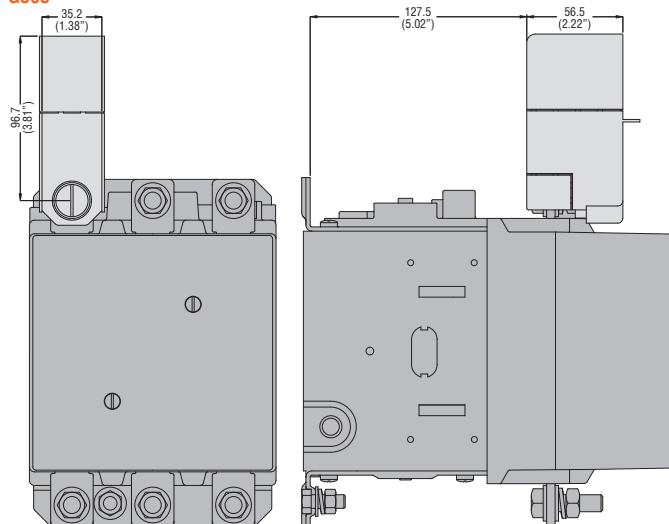

#### G527, G529

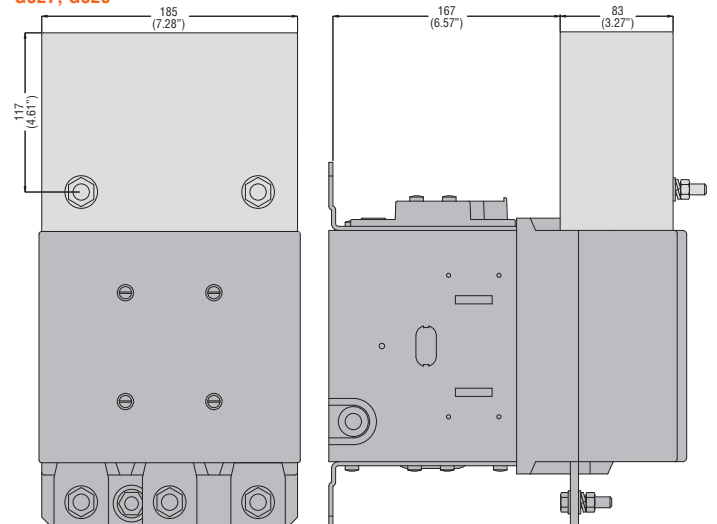



## 2 Contactors

Dimensions [mm (in)]

### G528, G530

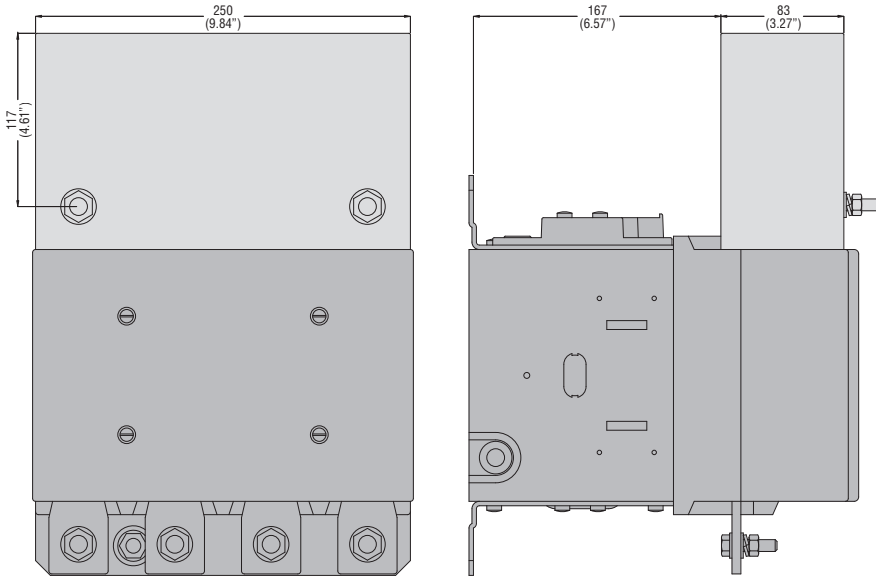

### BA1594, BA1720 parallel 2-pole bar

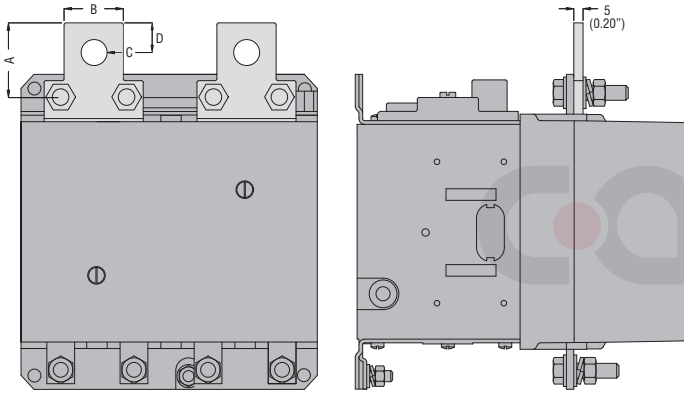

### G495 mechanical latch

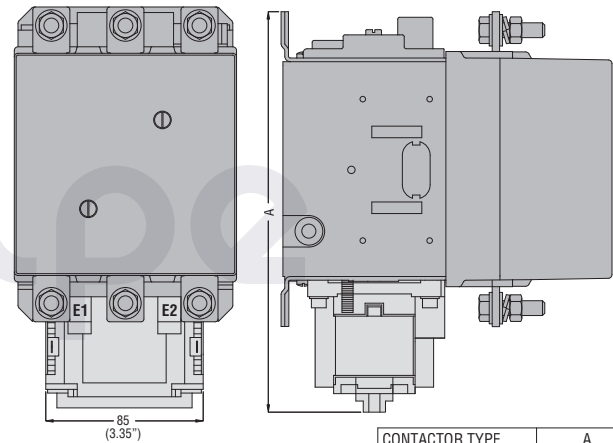

PARALLEL POLE BAR	A	B	C	D
BA1594	45 (1.77")	32 (1.26")	Ø14 (0.55")	16 (0.63")
BA1720	53 (2.09")	50 (1.97")	Ø18 (0.71")	20 (0.79")

CONTACTOR TYPE	A
B250 - B400	255 (8.86")
B500 - B630	300 (11.81")

### BA1845

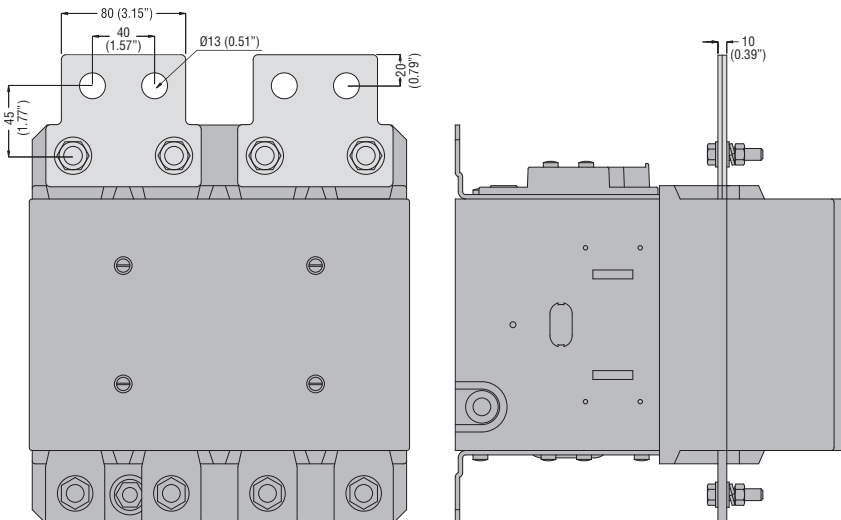



# 2 Contactors

## Wiring diagrams

### THREE-POLE CONTACTORS IN AC

**BG06A - BG09A - BGF09A - BGP09A - BG12A**  
**BF09A - BF12A - BF18A - BF25A**

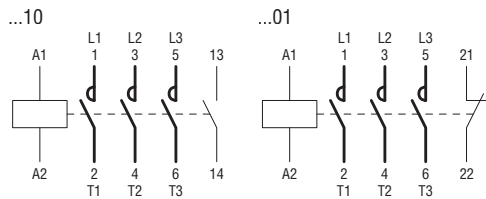

**BF26A - BF32A - BF38A**  
**BF40A - BF50A - BF65A - BF80A**  
**BF94A - BF95A - BF115A - BF150A**  
**B250...B630**

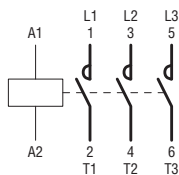

**B125024 - B160024... ①**

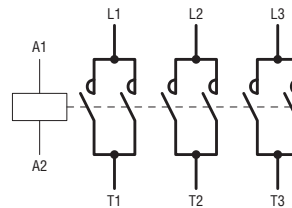

① The input electronic circuit of the contactor coil is designed and tested according to IEEEC 62.41 standards and can withstand a 10kV impulse voltage (1.2/50µs) with 50 Joule energy. The use of an auxiliary reduced voltage transformer is recommended for higher values.

2

### THREE-POLE CONTACTORS IN DC (AC/DC for BF40E...BF230E)

**BG06D - BG09D - BGF09D - BGP09D - BG12D**  
**BG06L - BG09L - BGF09L - BGP09L - BG12L**

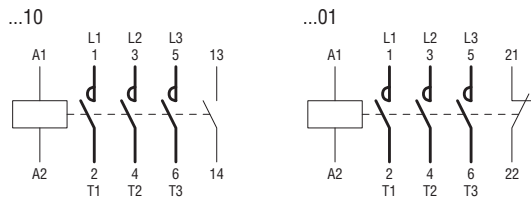

**BF09D - BF12D - BF18D - BF25D**  
**BF09L - BF12L - BF18L - BF25L**

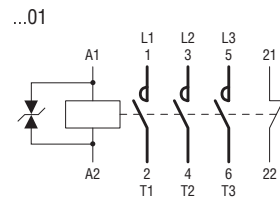
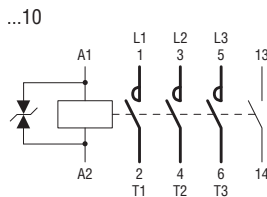

**BF26D - BF32D - BF38D**  
**BF26L - BF32L - BF38L**

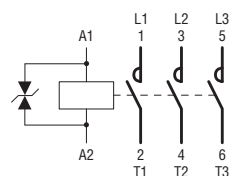

**BF40E - BF50E - BF65E - BF80E - BF94E**  
**BF95E - BF115E - BF150E - BF160E - BF195E - BF230E**

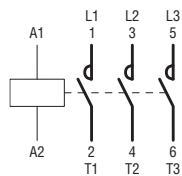

### CONTACTORS FOR POWER FACTOR CORRECTION

**BFK09A - BFK12A - BFK18A**  
**BFK26A - BFK32A - BFK38A - BFK50A - BFK65A - BFK80A - BFK94A - BFK95A - BFK115A - BFK150A**

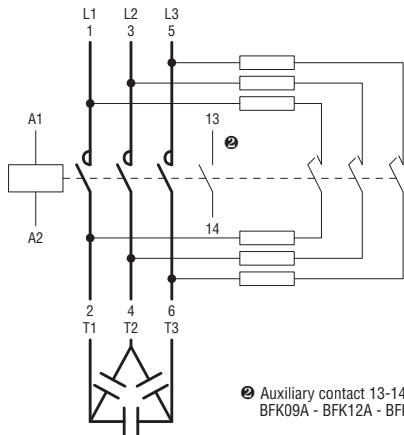

② Auxiliary contact 13-14 is found on BFK09A - BFK12A - BFK18A types only.







# 2 Contactors

## Wiring diagrams

**FOUR-POLE CONTACTORS IN AC**  
**BG09T4A - BGF09T4A - BGP09T4A**  
**BF09T4A - BF38T4A**  
**BF50T4A - BF65T4A - BF80T4A**  
**BF95T4A - BF115T4A - BF150T4A**  
**BFD80T4A**  
**B250...B6304**

**B12504 - B16004**

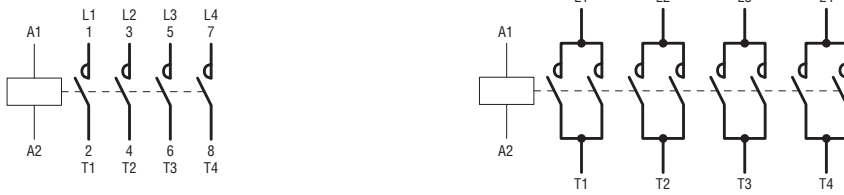

**FOUR-POLE CONTACTORS IN DC (AC/DC for BF65T4E...BF150T4E)**  
**BG09T4D - BGF09T4D - BGP09T4D**  
**BF09T4D - BF38T4D**  
**BF09T4L - BF38T4L**

**BF65T4E - BF80T4E - BF95T4E - BF150T4E - BFD150T4E**  
**BF160T4E - BF195T4E - BF230T4E**

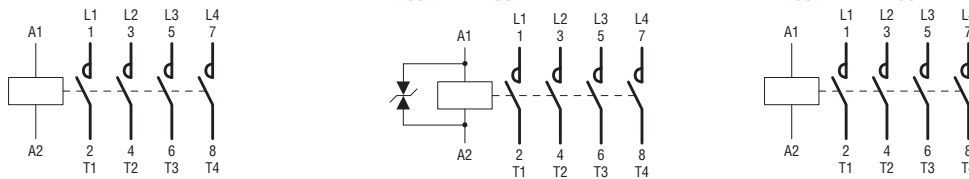

**FOUR-POLE CONTACTORS IN AC WITH 2NO AND 2NC POLES**  
**BG09T2A**

**BF09T2A - BF18T2A - BF26T2A - BF38T2A**  
**BF80T2A**

**WITH NC FOUR-POLES**  
**BF18T0A - BF26T0A**

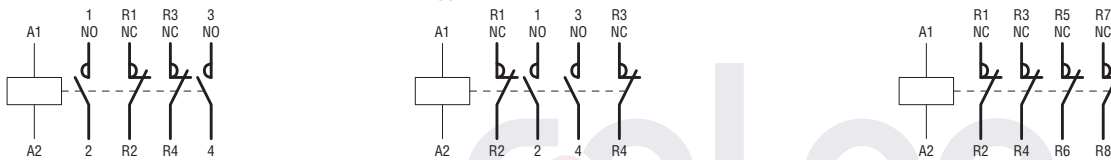

**FOUR-POLE CONTACTORS IN DC (AC/DC for BF80T2E) WITH 2NO AND 2NC POLES**  
**BG09T2D**

**BF18T2D - BF26T2D - BF38T2D**  
**BF18T2L - BF26T2L - BF38T2L**

**BF80T2E**

**WITH NC FOUR-POLES**  
**BF18T0D - BF26T0D**  
**BF18T0L**



**CONTROL RELAY IN AC**  
**BG0040A - BGF0040A**  
**BF0040A**

**BG0031A - BGF0031A**  
**BF0031A**

**BG0022A - BGF0022A**  
**BF0022A**

**BF0004A**

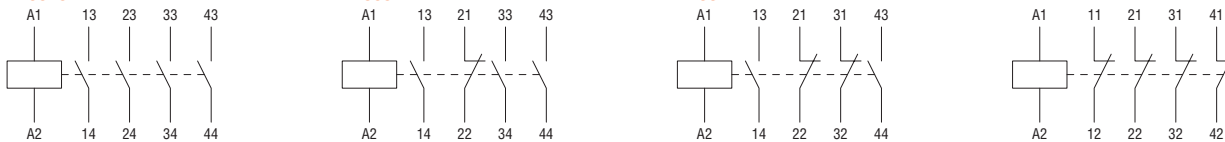

**CONTROL RELAY IN DC**  
**BG0040D - BGF0040D**  
**BG0040L - BGF0040L**

**BG0031D - BGF0031D**  
**BG0031L - BGF0031L**

**BG0022D - BGF0022D**  
**BG0022L - BGF0022L**

**BF0004D**  
**BF0004L**

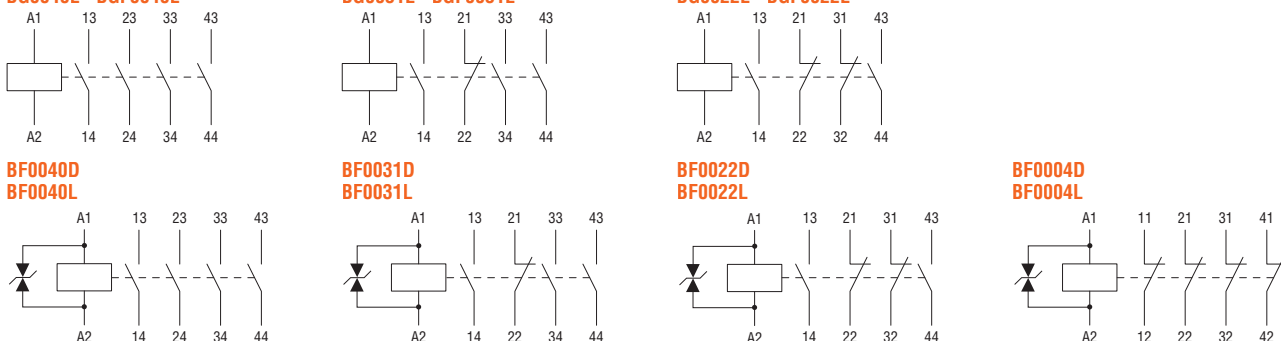



# 2 Contactors

## Wiring diagrams

### ADD-ON BLOCKS FOR BG MINI-CONTACTORS

Auxiliary contacts

**BGX1002**  
**BGXF1002**

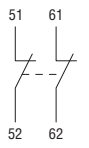

**BGX1011**  
**BGXF1011**

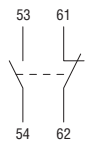

**BGX1020**  
**BGXF1020**

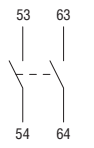

**BGX1004**  
**BGXF1004**

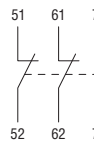

**BGX1013**  
**BGXF1013**

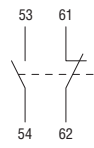

**BGX1022**  
**BGXF1022**

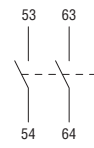

**BGX1031**  
**BGXF1031**

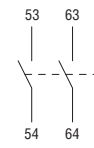

**BGX1040**  
**BGXF1040**

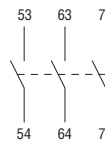

Special auxiliary contacts

**BGX1111**

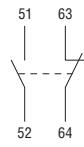

**BGX1122**

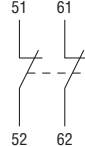

Surge suppressor

**BGX77...**

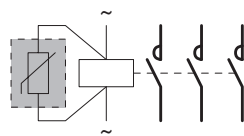

**BGX78...**

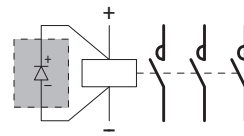

**BGX79...**

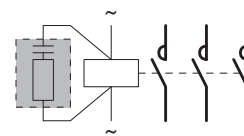

Rigid connections

**SMX9021**

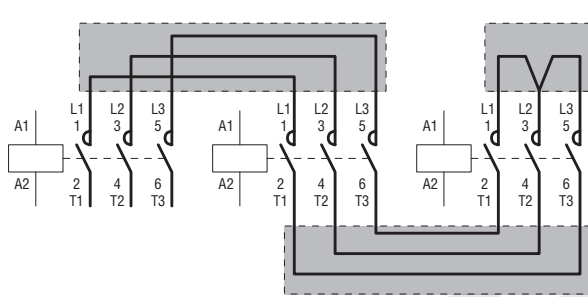

**SMX9022**

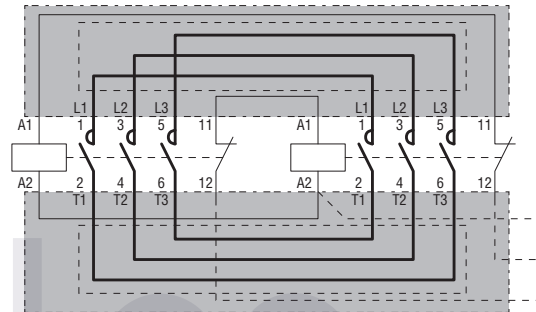

### ADD-ON BLOCKS FOR BF CONTACTORS

Auxiliary contacts

**BFX1002**

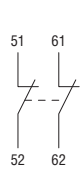

**BFX1011**

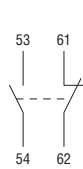

**BFX1020**



**G48430**

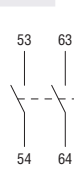

**G48421**

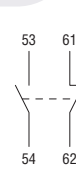

**G48412**

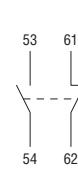

**G48403**

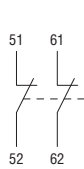

**BFX1004**

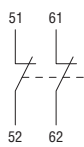

**BFX1013**

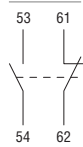

**BFX1022**

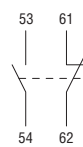

**BFX1031**

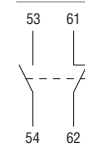

**BFX1040**

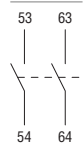

**BFX101111**

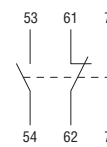

Auxiliary contact

**G218**

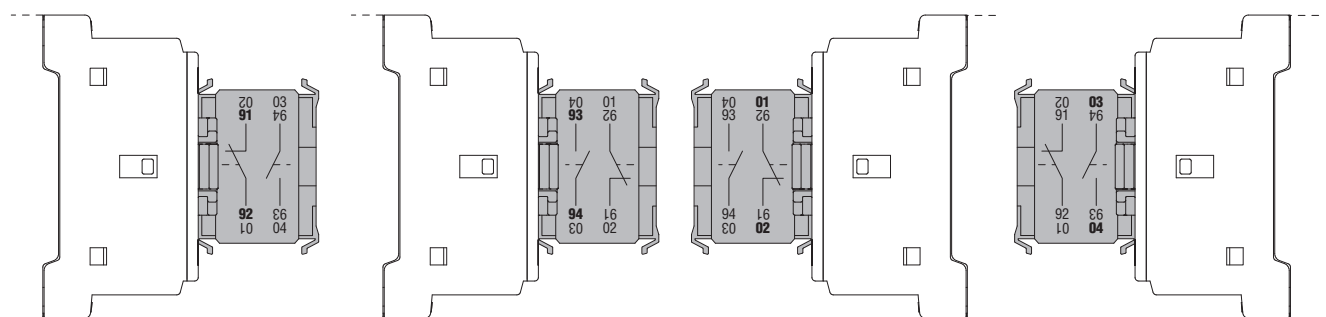

The termination of the G218 auxiliary contact has more than one numbering due to the fact that the block can assume various mounting positions. See the numbering in boldface for a correct interpretation.



# 2 Contactors

## Wiring diagrams

Auxiliary contacts

**BFX1202**  
**BFX12C02**

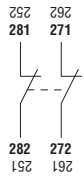

**BFX1211**  
**BFX12C11**

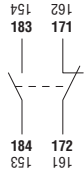

**BFX1220**  
**BFX12C20**

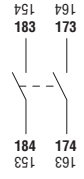

**BFX10C10**



**BFX10C01**



**G41810**  
**G42810**



**G41810A**  
**G42810A**



**G41801**  
**G42801**



**G41801D**  
**G42801D**



**G48120**

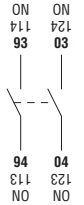

**G48111**

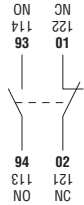

**G48102**

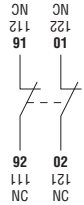

**G482**



Mechanical latch  
**G222... - G272...**

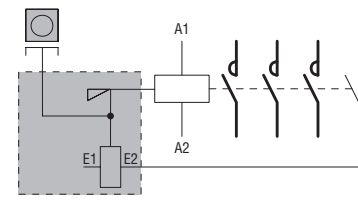

The termination of the BFX12... / G418... / G481... / G482 auxiliary contacts has more than one numbering due to the fact that the block can assume various mounting positions. See the numbering in boldface when the block is mounted on the left side of the contactor.

4th pole  
**BFX42 - BFX43 - BFX44**  
**BFXD42**



Interlock  
**BFX5001 - BFX5301**  
**BFX5401**

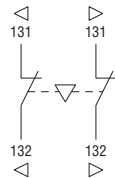

Delayed auxiliary contacts  
**G485... G486... - G487**

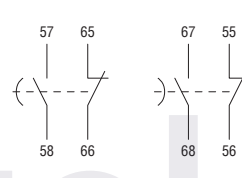

Rigid connecting kits  
**BFX3101 - BFX3102 - BFX3201**  
**BFX3301 - BFX3401**

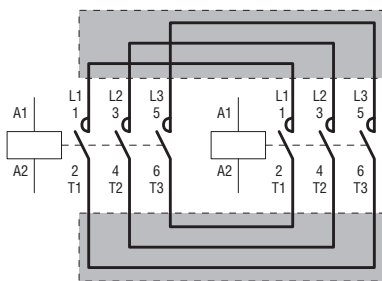

**BFX3131 - BFX3231 - BFX3232 - BFX3331 - BFX3332 - BFX3431 - BFX3432**

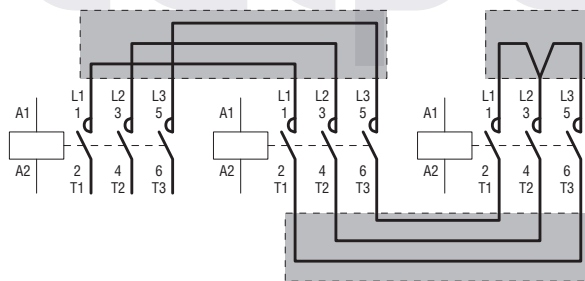

**BFX3361 - BFX3461**

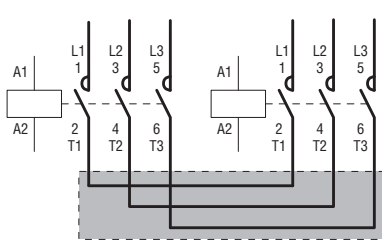

**BFX3371 - BFX3471**

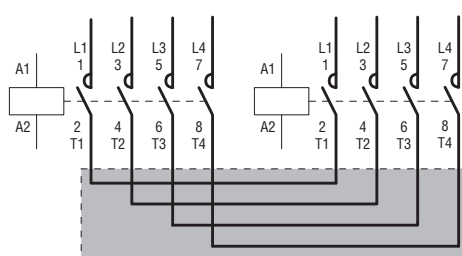



## 2 Contactors

### Wiring diagrams

#### ADD-ON BLOCKS FOR B CONTACTORS

##### Auxiliary contacts

##### G350 - G354

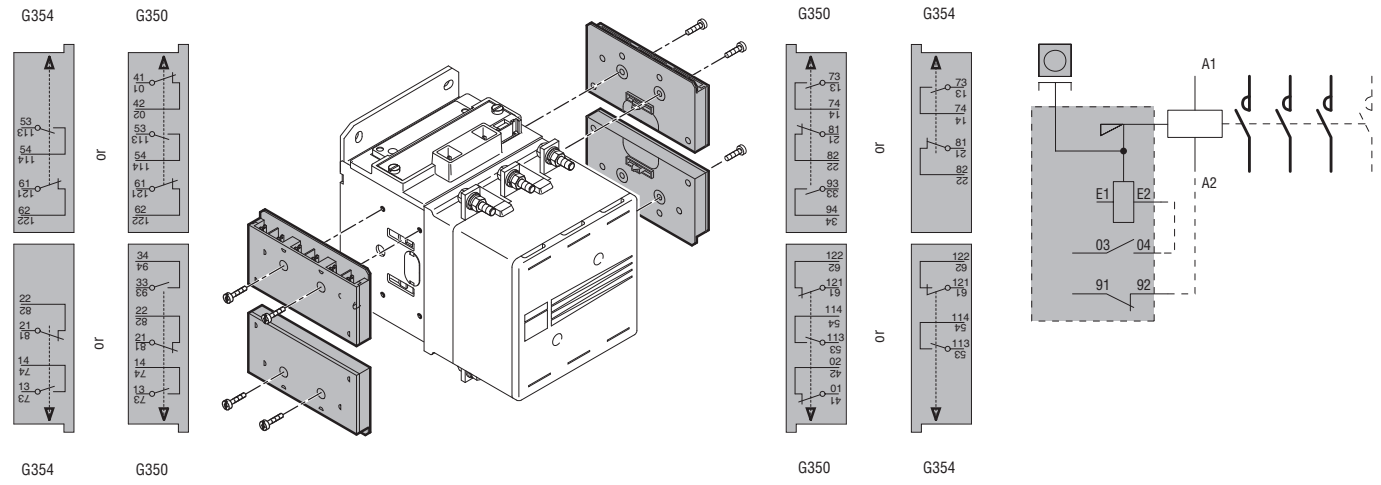





## 2 Contactors

### Technical characteristics

#### MOUNTING POSITION OF CONTACTORS

##### ON VERTICAL PLANE

The performances given in this catalogue have been established with contactors mounted on a vertical plane with line terminals facing upwards and load terminals facing downwards.

All contactors can be mounted with a  $\pm 30^\circ$  inclination to the vertical axis of the contactor without any derating.

For BF series contactors, this inclination can reach  $\pm 90^\circ$ , that is when the terminals are facing towards left and right.

For BG mini-contactors:

- Position A, with coil terminals A1-A2 facing downwards, is not recommended.
- The position with coil terminals A1-A2 facing upwards is not recommended for mini-contactors with NC contacts.



##### ON VERTICAL PLANE WITH 30° INCLINATION

All contactors can be mounted on a plane which varies in respect to the vertical up to  $\pm 30^\circ$  angle.

On the average, a 5% increase of the minimum pick-up voltage in  $-30^\circ$  position can be noted.

This inclination is greater than the one prescribed by main naval registers.

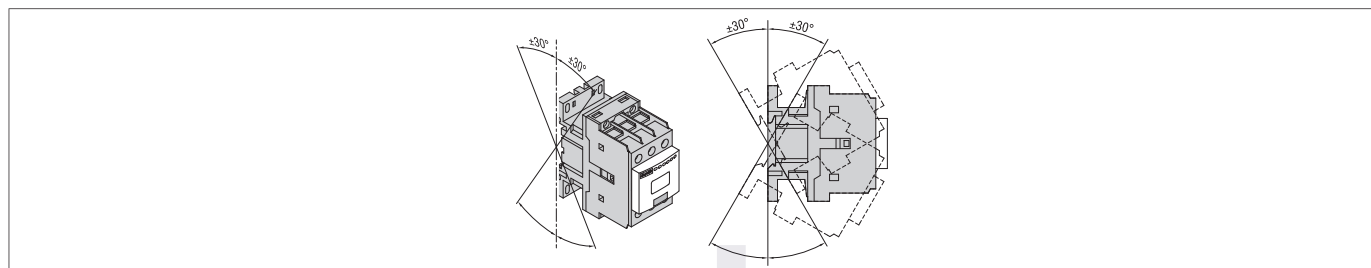

##### ON HORIZONTAL PLANE (FOR BF SERIES CONTACTORS)

Considerable performance variations can be noted.

It is necessary to check the two possible mounting positions:

- when the contactor is energised, the movable equipment moves upwards.
- when the contactor is energised, the movable equipment moves downwards.

In the first case, it is difficult to close the contactor while in the second, to open it.

The variables which could influence the contactor performance, in addition to the two mounting positions, are:

- type of contactor
- type of control
- contact configuration
- number and type of add-on blocks
- permissible tolerance of auxiliary voltage variation
- ambient temperature.

NOTE: Position B is not recommendable.

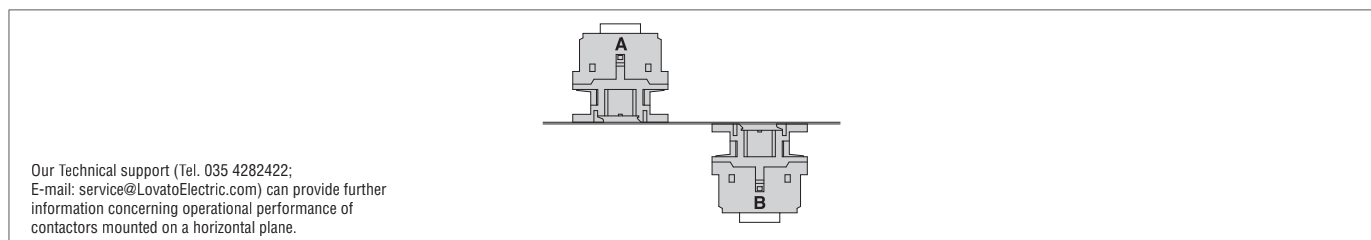

Our Technical support (Tel. 035 4282422;  
E-mail: [service@LovatoElectric.com](mailto:service@LovatoElectric.com)) can provide further information concerning operational performance of contactors mounted on a horizontal plane.

#### DYNAMIC TYPE TESTS

Our contactors have sustained dynamic testing, with contactor mounting position rotated  $\pm 22.5^\circ$  in respect to the three orthogonal axes.

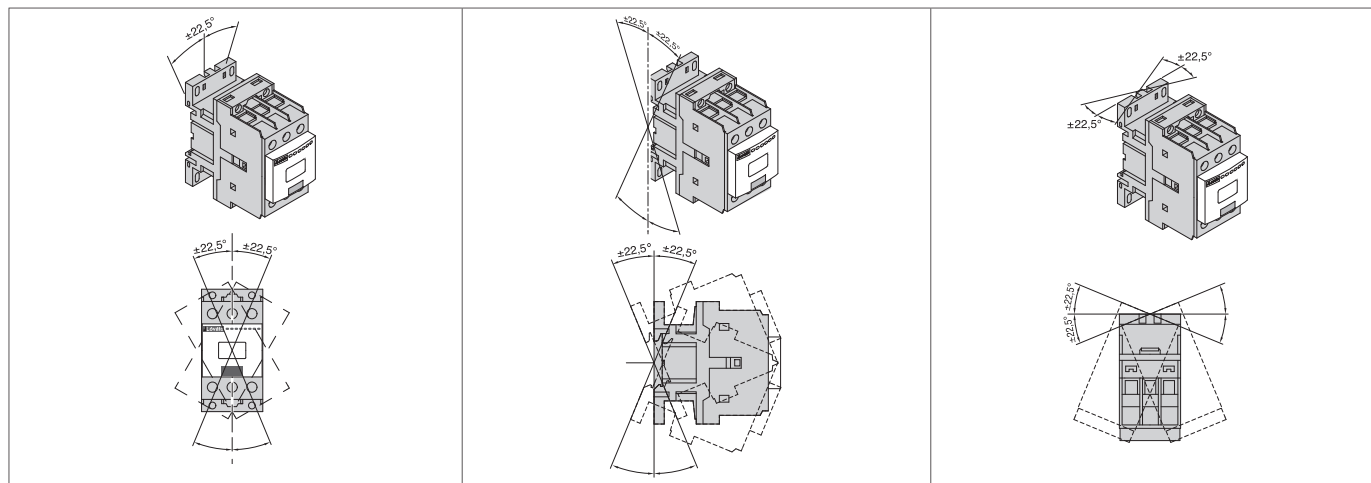



# 2 Contactors

## Technical characteristics

### IEC UTILISATION CATEGORY AC3

#### POLE CHARACTERISTICS

Squirrel-cage induction motors; breaking at rated motor current.

MAXIMUM IEC OPERATIONAL POWER at ambient temperature  $\leq 55^{\circ}\text{C}$ .

Contactor type	IEC operational current (U <sub>e</sub> $\leq$ 440V) [A]	IEC operational power							Maximum horsepower ratings (60Hz)			
		220/230V [kW]	380/400V [kW]	415V [kW]	440V [kW]	500V [kW]	660/690V [kW]	1000V [kW]	Three phase 200-208V [HP]	240V [HP]	480V [HP]	600V [HP]
BG06	6	1.5	2.2	2.4	2.5	3	3	-	1½	2	3	3
BG09	9	2.2	4.0	4.3	4.5	5	5	-	2	3	5	5
BG12	12	3.2	5.7	6.2	5.5	5	5	-	3	3	7½	10
BF09	9	2.2	4.2	4.5	4.8	5.5	7.5	-	3	3	5	7 ½
BF12	12	3.2	5.7	6.2	6.2	7.5	10	-	5	5	7½	10
BF18	18	4	7.5	9	9	10	10	-	5	5	10	15
BF25	25	7.0	12.5	13.4	13.4	15	18	-	7½	7½	15	15
BF26	26	7.3	13	14	14	15.6	18.5	-	7½	7½	15	20
BF32	32	8.8	16	17	17	20	22	-	10	10	20	25
BF38	38	11	18.5	18.5	18.5	20	22	-	10	15	30	30
BF40	40	11	18.5	22	22	22	30	18	10	15	30	30
BF50	50	15	22	30	30	30	37	22	15	20	40	40
BF65	65	18.5	30	37	37	37	45	30	20	25	50	60
BF80	80	22	45	45	45	55	55	37	25	30	60	75
BF94	95	30	55	55	55	55	55	37	25	30	60	75
BF95	95	30	55	55	55	75	90	45	30	30	60	75
BF115	115	37	55	55	55	75	110	55	40	40	75	100
BF150	150	45	75	75	75	90	110	55	50	50	100	125
BF160	160	45	75	90	90	110	132	75	50	50	100	125
BF195	195	55	90	110	110	132	160	90	60	75	150	150
BF230	230	55	110	110	132	132	160	110	75	75	150	200
B250	265	83	140	155	164	176	212	156	75	100	200	250
B310	320	100	170	188	200	213	256	180	100	125	250	300
B400	420	130	225	247	263	271	352	208	125	150	350	400
B500	520	156	290	306	328	367	416	312	150 ①	200 ①	400 ①	450 ①
B630	630	198	335	368	368	368	440	368	200 ①	250 ①	500 ①	500 ①

① No UL/CSA ratings; data given for indication and reference purposes only.

### ELECTRICAL IEC LIFE FOR MOTOR CONTROL AC3 $\leq 440\text{V}$

Electrical life of contactors

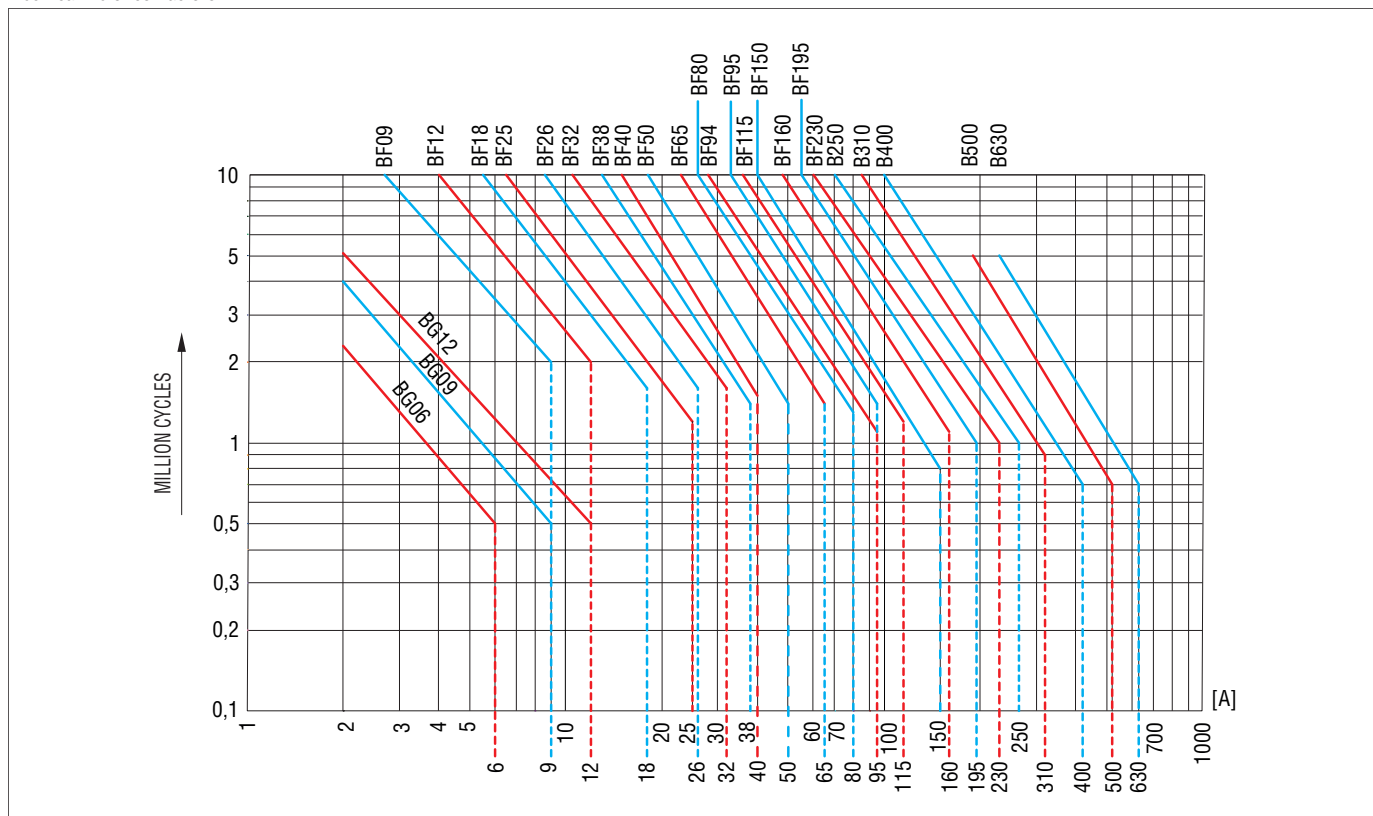



## 2 Contactors

### Technical characteristics

#### IEC DC UTILISATION CATEGORY POLE CHARACTERISTICS

#### MAXIMUM OPERATIONAL CURRENT

IEC Voltage U <sub>e</sub>	Contactor Type	IEC Maximum current I <sub>e</sub> [A] in categories: DC1 with L/R ≤ 1ms and poles in series				DC3 - DC5 with L/R ≤ 15ms and poles in series			
		1	2	3	4	1	2	3	4
≤ 24V	<b>BG06</b>	9	12	14	–	6	7	9	–
	<b>BG09</b>	12	15	16	16	7	8	10	10
	<b>BG12</b>	12	15	16	–	7	8	10	–
	<b>BF09</b>	15	18	20	20	10	13	15	15
	<b>BF12</b>	17	20	22	20	12	15	18	15
	<b>BF18</b>	17	20	22	22	12	15	18	18
	<b>BF25</b>	20	23	23	–	15	18	22	–
	<b>BF26</b>	25	28	28	28	18	20	25	30
	<b>BF32</b>	30	32	32	–	20	25	30	–
	<b>BF38</b>	35	36	36	36	24	28	32	32
	<b>BF40</b>	40	48	48	–	27	32	40	–
	<b>BF50</b>	45	60	60	60	30	35	50	55
	<b>BF65</b>	50	70	70	70	35	45	55	60
	<b>BF80</b>	70	100	100	100	40	60	80	90
	<b>BF94</b>	77	110	110	115	45	65	86	96
	<b>BF95</b>	140	140	140	140	140	140	140	140
<b>BF115</b>	160	160	160	160	160	160	160	160	
<b>BF150</b>	165	165	165	165	165	165	165	165	
48V	<b>BG06</b>	8	11	14	–	5	7	9	–
	<b>BG09</b>	10	14	16	16	6	8	10	10
	<b>BG12</b>	10	14	16	–	6	8	10	–
	<b>BF09</b>	13	18	20	20	9	11	15	15
	<b>BF12</b>	15	20	22	20	11	13	18	15
	<b>BF18</b>	15	20	22	22	11	13	18	18
	<b>BF25</b>	18	23	23	–	13	18	22	–
	<b>BF26</b>	21	28	28	28	15	20	25	30
	<b>BF32</b>	26	32	32	–	17	22	28	–
	<b>BF38</b>	30	34	34	34	20	25	28	28
	<b>BF40</b>	35	48	48	–	23	30	40	–
	<b>BF50</b>	40	60	60	60	25	35	50	55
	<b>BF65</b>	50	70	70	70	25	40	50	60
	<b>BF80</b>	60	100	100	100	30	50	70	90
	<b>BF94</b>	66	110	110	115	33	55	75	95
	<b>BF95</b>	140	140	140	140	44	63	115	110
<b>BF115</b>	160	160	160	160	50	72	150	120	
<b>BF150</b>	165	165	165	165	60	82	195	130	
75V	<b>BG06</b>	4	7	8	–	2	4	5	–
	<b>BG09</b>	4	9	10	10	2	5	6	6
	<b>BG12</b>	4	9	10	–	2	5	6	–
	<b>BF09</b>	12	17	20	20	8	10	13	15
	<b>BF12</b>	13	18	20	20	10	12	15	15
	<b>BF18</b>	15	20	20	20	11	13	16	16
	<b>BF25</b>	18	23	23	–	13	16	18	–
	<b>BF26</b>	18	25	25	25	13	18	20	25
	<b>BF32</b>	22	28	32	–	15	20	28	–
	<b>BF38</b>	23	29	33	33	17	22	28	28
	<b>BF40</b>	30	45	48	–	19	27	38	–
	<b>BF50</b>	40	60	60	60	22	30	45	55
	<b>BF65</b>	50	70	70	70	25	40	50	60
	<b>BF80</b>	60	100	100	100	30	50	70	90
	<b>BF94</b>	66	110	110	115	33	55	75	95
	<b>BF95</b>	100	140	155	155	36	60	90	110
<b>BF115</b>	120	160	160	160	40	65	100	120	
<b>BF150</b>	150	165	165	165	44	70	110	130	

# 2 Contactors

## Technical characteristics

### POLE CHARACTERISTICS

### MAXIMUM OPERATIONAL CURRENT

IEC Voltage Ue	Contactor Type	IEC Maximum current Ie [A] in categories:							
		DC1 with L/R ≤ 1ms and poles in series				DC3 - DC5 with L/R ≤ 15ms and poles in series			
		1	2	3	4	1	2	3	4
110V	<b>BG06</b>	3	6	8	–	1	3	4	–
	<b>BG09</b>	3	8	10	10	1	4	5	5
	<b>BG12</b>	3	8	10	–	1	4	5	–
	<b>BF09</b>	6	12	15	16	2	7	11	12
	<b>BF12</b>	6	13	16	16	2	8	12	16
	<b>BF18</b>	6	13	16	18	2	8	12	13
	<b>BF25</b>	6	16	18	–	2	10	15	–
	<b>BF26</b>	6	22	24	24	2	13	18	20
	<b>BF32</b>	8	25	27	–	2,5	15	20	–
	<b>BF38</b>	8	32	34	34	2,5	18	23	23
	<b>BF40</b>	8	42	44	–	3	22	27	–
	<b>BF50</b>	8	50	55	60	3	25	30	45
	<b>BF65</b>	8	60	60	70	3	30	35	50
	<b>BF80</b>	8	80	85	100	3	40	60	75
	<b>BF94</b>	8	90	93	110	3	43	64	80
	<b>BF95</b>	10	110	120	140	6	55	85	105
	<b>BF115</b>	10	130	140	160	6	65	100	125
	<b>BF150</b>	10	150	160	165	6	80	120	150
220V	<b>BG06</b>	–	–	1	–	–	–	0,5	–
	<b>BG09</b>	–	–	2	2	–	–	0,8	0,8
	<b>BG12</b>	–	–	2	–	–	–	0,8	–
	<b>BF09</b>	–	1	10	12	–	2	6	7
	<b>BF12</b>	–	1	11	12	–	2	6	7
	<b>BF18</b>	–	1	11	13	–	2	6	8
	<b>BF25</b>	–	1	12	–	–	2	8	–
	<b>BF26</b>	–	2	20	26	–	3	19	15
	<b>BF32</b>	–	3	23	–	–	3	23	–
	<b>BF38</b>	–	4	30	38	–	3	25	15
	<b>BF40</b>	–	5	56	70	–	5	32	40
	<b>BF50</b>	–	7	75	90	–	5	40	50
	<b>BF65</b>	–	9	90	110	–	5	52	65
	<b>BF80</b>	–	9	95	115	–	5	64	80
	<b>BF94</b>	–	9	95	115	–	5	64	80
	<b>BF95</b>	–	12	125	140	–	7	76	95
	<b>BF115</b>	–	14	145	160	–	7	92	115
	<b>BF150</b>	–	14	150	165	–	7	120	150



## 2 Contactors

Technical characteristics

### IEC DC UTILISATION CATEGORY POLE CHARACTERISTICS

#### MAXIMUM OPERATIONAL CURRENT

IEC Voltage U <sub>e</sub>	Contactor Type	IEC Maximum current I <sub>e</sub> [A] in categories: DC1 with L/R ≤ 1ms and poles in series				DC3 - DC5 with L/R ≤ 15ms and poles in series			
		1	2	3	4	1	2	3	4
75V	<b>BF160</b>	250	250	250	250	160	160	160	160
	<b>BF195</b>	275	275	275	275	180	180	180	180
	<b>BF230</b>	350	350	350	350	250	250	250	250
	<b>B250</b>	350	350	350	350	280	280	280	280
	<b>B310</b>	375	375	375	375	310	310	310	310
	<b>B400</b>	400	400	400	400	350	350	350	350
	<b>B500</b>	650	650	650	650	550	550	550	550
	<b>B630</b>	800	800	800	800	800	800	800	800
110V	<b>BF160</b>	110	150	150	150	80	120	140	140
	<b>BF195</b>	120	170	170	170	90	140	160	160
	<b>BF230</b>	145	270	270	270	135	225	250	250
	<b>B250</b>	160	300	300	300	150	250	280	280
	<b>B310</b>	195	350	350	350	170	290	310	310
	<b>B400</b>	250	400	400	400	200	350	350	350
	<b>B500</b>	320	550	600	600	320	550	550	550
	<b>B630</b>	460	800	800	800	460	800	800	800
220V	<b>BF160</b>	-	130	150	150	-	90	120	140
	<b>BF195</b>	-	150	170	170	-	100	140	160
	<b>BF230</b>	-	225	270	270	-	180	225	225
	<b>B250</b>	-	250	300	300	-	200	250	280
	<b>B310</b>	-	300	350	350	-	230	290	310
	<b>B400</b>	-	350	400	400	-	280	350	350
	<b>B500</b>	-	450	600	600	-	450	550	550
	<b>B630</b>	-	700	800	800	-	700	800	800
330V	<b>BF160</b>	-	-	130	150	-	-	90	140
	<b>BF195</b>	-	-	150	170	-	-	100	160
	<b>BF230</b>	-	-	225	270	-	-	180	250
	<b>B250</b>	-	-	250	300	-	-	200	280
	<b>B310</b>	-	-	300	350	-	-	230	310
	<b>B400</b>	-	-	350	400	-	-	280	350
	<b>B500</b>	-	-	450	600	-	-	450	550
	<b>B630</b>	-	-	700	750	-	-	650	700
460V	<b>BF160</b>	-	-	-	130	-	-	-	90
	<b>BF195</b>	-	-	-	150	-	-	-	100
	<b>BF230</b>	-	-	-	225	-	-	-	180
	<b>B250</b>	-	-	-	250	-	-	-	200
	<b>B310</b>	-	-	-	300	-	-	-	230
	<b>B400</b>	-	-	-	350	-	-	-	280
	<b>B500</b>	-	-	-	450	-	-	-	450
	<b>B630</b>	-	-	-	700	-	-	-	700



# 2 Contactors

## Technical characteristics

### IEC UTILISATION CATEGORIES DC1, DC3 AND DC5.

#### POLE CHARACTERISTICS

##### CHOICE CRITERIA

The elements to be considered for the contactor choice are:

- Rated operational current Ie
- Rated operational voltage Ue
- Utilisation category and L/R time constant
- Eventual verification of electrical life.

##### OPERATING CONDITIONS

Indicated current is valid for:

- Ambient temperature  $\leq 55^{\circ}\text{C}$
- Operating cycles: up to 120 cy/h with 60% on-load factor  
up to 250 cy/h with 30% on-load factor.

#### POLES IN SERIES

It is important to use contactors with the indicated number of poles in series depending on operating voltage.

The poles in series can be connected to one single polarity or divided between the two polarities of the circuit indifferently.

NOTE. For voltages lower than 30V, the diagrams given in figures 3 and 4 are not recommendable since voltage drops can take place. In these cases, it is better to use poles in parallel considering the notes given in the following section.

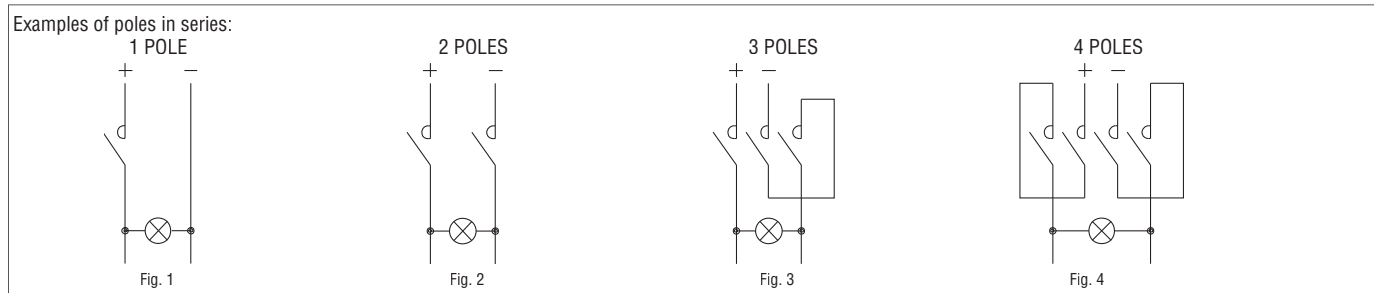

#### POLES IN PARALLEL

It is possible to increase the electrical life by placing poles in series when using voltages which require 1 or 2 poles in parallel.

Poles in parallel do not increase the maximum operational current given in the previous pages; that is, if one pole has a maximum operational current in DC5 of 8A, two poles in parallel, it will always be 8A.

With poles in parallel, it is possible to increase the rated contact capacity (Ith) only if the contactor opens and closes in no-load conditions or when used as resistance shunts.

In this case, the contact capacity can be increased.

The value can be obtained by multiplying the rated current of one pole by the K factor given below; e.g.: if one pole carries 10A, three poles in parallel can carry  $10 \times 2.2 = 22\text{A}$ .

Therefore, the operating current is the one indicated in the tables, multiplied by the K factor given below which takes into consideration the unequal current division on the various poles.

- 2 POLES in parallel K = 1.6
- 3 POLES in parallel K = 2.2
- 4 POLES in parallel K = 2.8

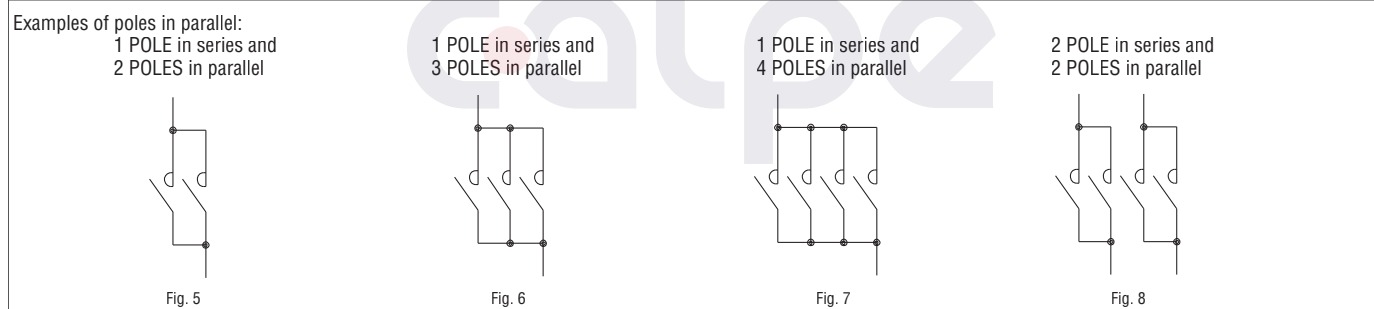

#### MAXIMUM OPERATIONAL CURRENT

See tables on pages 2-57 to 2-59.

#### OTHER CONDITIONS

For different operating conditions or voltage not included among those indicated in the tables, on pages 2-57 to 2-59, consult Technical support (Tel. 035 4282422; E-mail: [service@LovatoElectric.com](mailto:service@LovatoElectric.com)).



# 2 Contactors

## Technical characteristics

### IEC SELECTION GUIDE FOR LIGHTING CIRCUIT SWITCHING

#### GENERAL INFORMATION

The elements which are to be considered for the contactor choice are:

- Type of lamp
- Power factor (cosφ)
- With or without power factor correction
- Value of current when switching on and in running conditions.

Depending on the number and type of lamps, it is also important to bear in mind the main discriminating characteristics given below for the contactor choice:

- Incandescent lamps → contactor making capacity
- Lamps not corrected → rated contactor current in AC1
- Lamps corrected → rated contactor current in AC3

The table below summarises the major characteristics depending on the more commonly used type of lamps:

Type of lamps	Switching on Multiple of In <sup>①</sup>	cosφ	Switching off Multiple of In <sup>①</sup>	cosφ
Incandescent	15	1	1	1
Mixed light	1.3	1	1	1
Fluorescent	1.15 - 1.3	0.2	1	0.3 - 0.5 (not corrected) 1 (corrected)
High-pressure mercury vapour	1.5 - 1.75	0.2	1	0.45 - 0.7 (not corrected)
High-pressure sodium vapour	1.3 - 1.5	0.2	1	0.3 - 0.5 (not corrected)
Low-pressure sodium vapour	1	0.2 - 0.5	1	0.2 - 0.5 (not corrected)
Metal halide	1.7 - 2.1	0.2	1	0.4 - 0.5 (not corrected)
LED	20...40 <sup>②</sup>	0.6...0.95	1	0.6...0.95

Lamp features	Lamp power [W]	Rated current [A]	Capacitor capacity [μF]	Maximum number [n] of lamps for each contactor pole <sup>②</sup>											
				BG06 BG09 BG12	BF09 BF12 BF18	BF25	BF26 BF32	BF38	BF40 BF50	BF65 BF80 BF94	BF95	BF115 BF150	BF160	BF195 BF230	
LED 220...240V 50/60Hz	See note <sup>③</sup>			Each pole can carry 67% of the rated current AC3 <sup>④</sup>											
INCANDESCENT 220...240V	50/60Hz	60	0.27	-	30	48	92	118	129	203	240	296	370	425	462
		100	0.45	-	18	28	55	71	77	122	144	177	222	255	277
		200	0.91	-	8	14	27	35	38	60	71	87	109	126	137
		300	1.4	-	5	9	17	22	25	39	46	57	71	82	89
		500	2.3	-	3	5	10	13	15	23	28	34	43	50	54
MIXED LIGHT 220...240V	50/60Hz	100	0.45	-	20	33	57	77	88	122	144	177	244	311	377
		160	0.72	-	12	20	36	48	55	76	90	111	152	194	236
		250	1.13	-	8	13	23	30	35	48	57	70	97	123	150
		500	2.3	-	4	6	11	15	17	23	28	34	47	60	73
		1000	4.6	-	1	3	5	7	8	11	14	17	23	30	36
ELECTRONIC BALLAST FLUORESCENT 220...240V 50/60Hz (EVG)	Single mounting	16 / 18	0.1	(6.8) <sup>⑤</sup>	48	80	160	220	220	400	450	500	750	1050	1200
		32 / 36	0.18	(6.8) <sup>⑤</sup>	27	44	88	122	122	222	250	277	416	583	666
	Dual mounting	50 / 58	0.27	(10) <sup>⑤</sup>	17	29	59	82	82	148	166	185	277	388	444
		2x16 / 18	0.18	(10) <sup>⑤</sup>	26	44	88	122	122	222	250	277	416	583	666
		2x32 / 36	0.35	(10) <sup>⑤</sup>	13	22	45	62	62	114	128	142	214	300	342
STANDARD FLUORESCENT 220...240V 50/60Hz	Not corrected Single mounting	15	0.35	-	25	42	74	100	114	157	185	228	314	400	485
		20	0.37	-	24	40	70	94	108	148	175	216	297	378	459
		40	0.44	-	20	34	59	79	90	125	147	181	250	318	386
		65	0.7	-	12	21	37	50	57	78	92	114	157	200	242
		115	1.5	-	6	10	17	23	26	36	43	53	73	93	113
	Corrected Single mounting	15	0.11	4.5	24	40	62	94	94	200	200	200	533	533	533
		20	0.16	4.5	24	40	62	94	94	200	200	200	533	533	533
		40	0.24	4.5	24	40	62	94	94	200	200	200	458	500	520
		65	0.4	7	15	25	40	50	57	125	128	128	275	300	312
		115	0.7	18	6	10	15	23	23	50	50	50	133	133	133
DUO circuit	2 x 20	0.26 <sup>④</sup>	-	54	57	100	153	153	211	250	307	423	538	653	
	2 x 40	0.46 <sup>④</sup>	-	19	32	56	86	86	119	141	173	239	304	369	
	2 x 65	0.7 <sup>④</sup>	-	12	21	37	57	57	78	92	114	157	200	242	
	2 x 115	1.3 <sup>④</sup>	-	6	11	20	30	30	42	50	61	84	107	130	
	2 x 140	1.5 <sup>④</sup>	-	6	10	17	26	26	36	43	53	73	93	113	

① In = Rated lamp current.

② For 220/240V circuits, either single-phase (between phase and neutral) or 2-wire (between phase and phase), the maximum number of lamps is as per the table.

For three-phase circuits with neutral 380/415V or 220/240V, the maximum number of lamps controlled by the same contactor is n \* 3.

For three-phase 380/415V circuits without neutral, the maximum number of lamps controlled by the same contactor is n \* √3.

Electrical life is 100,000 cycles up to 55°C.

③ Incorporated capacitor.

④ Total.

⑤ With reference to the AC side of the power supplies.

⑥ Usually, each light has its own power supply. If a power supply controls several lights, the number of power supplies must be factored into the calculation. The sum of the rated currents of the power supplies connected to each pole of the contact must not exceed 67% of the rated current AC-3 of the contactor indicated on page 2-6.

e.g. BF18 has a rated current AC-3 of 18A; it can control 18x0.67=12.06A per pole at most.



# 2 Contactors

## Technical characteristics

Lamp features		Lamp power [W]	Rated current [A]	Capacitor capacity [µF]	Maximum number [n] of lamps for each contactor pole <sup>①</sup>												
					BG06			BF09			BF65			BF155			BF195
					BG09	BF12	BF26	BF32	BF38	BF40	BF50	BF94	BF95	BF150	BF160	BF230	
HIGH-PRESSURE MERCURY VAPOUR 220/240V 50/60Hz	Not corrected	50	0.61	-	10	16	26	36	44	65	73	82	122	172	196		
		80	0.8	-	7	12	20	27	33	50	56	62	93	131	150		
		125	1.2	-	5	8	13	18	22	33	37	41	62	87	100		
		250	2.2	-	3	4	7	10	12	18	20	22	34	47	54		
		400	3.4	-	2	3	5	6	7	11	13	14	22	30	35		
		700	5.5	-		1	3	4	4	7	8	9	13	19	21		
		1000	8	-		1	2	2	3	5	5	6	9	13	15		
	Corrected	50	0.29	7	15	25	40	60	60	128	128	128	258	342	342		
		80	0.42	8	13	22	35	52	53	95	107	112	178	250	285		
		125	0.7	10	8	14	22	31	35	57	64	71	107	150	171		
		250	1.3	18	4	7	12	16	19	30	34	38	57	80	92		
		400	2.1	25	2	4	7	10	11	19	21	23	35	50	57		
		700	3.6	40	-	2	4	6	6	11	12	13	20	29	33		
		1000	5.3	60	-	1	3	4	4	7	8	9	14	19	22		
380/415V 50/60Hz	Not corrected	2000	8	-	-	-	1	2	2	3	3	4	5	8	9		
	Corrected	2000	5.5	35	-	-	1	2	2	4	5	5	8	11	13		
HIGH-PRESSURE SODIUM VAPOUR 220/240V 50/60Hz	Not corrected	150	1.8	-	3	5	8	12	15	22	25	27	41	58	66		
		250	3	-	2	3	5	7	9	13	15	16	25	35	40		
		400	4.7	-	1	2	3	4	5	8	9	10	15	22	25		
		600	7.1	-	-	1	2	3	3	5	6	6	10	15	16		
		1000	10.4	-	-	-	1	2	2	3	4	4	7	10	11		
		Corrected	150	0.83	20	-	9	14	19	21	45	45	45	90	120	120	
			250	1.5	36	-	5	7	10	11	25	25	25	50	66	66	
	400		2.4	48	-	3	5	6	7	16	18	18	31	43	50		
	600		3.5	68	-	2	3	4	4	10	12	12	20	28	34		
	1000		6.3	120	-	1	1	2	2	6	7	7	11	16	19		
	LOW-PRESSURE SODIUM VAPOUR 220/240V 50/60Hz		Not corrected	35	1.5	-	4	6	10	14	18	26	30	33	50	70	80
				55	1.5	-	4	6	10	14	18	26	30	33	50	70	80
		90		2.4	-	3	4	6	9	11	16	18	20	31	43	50	
		135		3.1	-	2	3	5	7	8	12	14	16	24	33	38	
150		3.2		-	2	3	5	6	8	12	14	15	23	32	37		
180		3.3		-	2	3	4	6	8	12	13	15	22	31	36		
Corrected		35		0.31	20	-	6	10	14	18	45	45	45	120	120	120	
	55	0.42	20	-	6	10	14	18	45	45	45	120	120	120			
	90	0.63	30	-	4	6	9	11	30	30	30	80	80	80			
	135	0.94	40	-	3	5	7	8	22	22	22	60	60	60			
	150	1	40	-	3	5	6	8	22	22	22	60	60	60			
	180	1.2	40	-	3	4	6	8	22	22	22	60	60	60			
	METAL HALIDE 220/240V 50/60Hz	Not corrected	35	0.3	-	-	28	50	66	80	100	150	167	250	330	400	
70			0.5	-	-	16	28	40	50	60	90	100	150	200	240		
150			1	-	-	8	14	20	25	30	45	50	75	100	120		
250			3	-	-	3	5	7	9	13	15	16	25	35	40		
400			3.5	-	-	2	4	6	7	11	12	14	21	30	34		
1000			10	-	-	1	1	2	2	4	4	5	7	10	12		
2000			17	-	-	-	-	1	1	2	2	2	4	6	7		
Corrected		35	0.17	6	-	33	60	65	65	200	240	260	400	420	440		
		70	0.28	12	-	20	36	40	40	120	145	155	240	255	265		
		150	0.6	20	-	9	17	18	18	56	68	74	112	118	120		
		250	1.5	32	-	5	7	8	10	26	28	28	46	50	53		
		400	2	35	-	4	5	6	7	20	22	25	35	37	40		
		1000	5.8	95	-	1	1	2	2	6	7	8	12	12	13		
		2000	11.5	148	-	-	-	1	1	3	3	4	6	6	6		
380/415V 50/60Hz	Not corrected	2000	10.3	-	-	-	-	1	1	2	2	3	4	6	7		
		3500	18	-	-	-	-	-	-	1	1	1	2	3	4		
	Corrected	2000	6.6	60	-	-	1	1	1	3	3	4	6	7	7		
		3500	11.6	100	-	-	-	-	-	2	2	2	3	3	4		

① For 220/240V circuits, either single-phase (between phase and neutral) or 2-wire (between phase and phase), the maximum number of lamps is as per the table.  
 For three-phase circuits with neutral 380/415V or 220/240V, the maximum number of lamps controlled by the same contactor is  $n \cdot 3$ .  
 For three-phase 380/415V circuits without neutral, the maximum number of lamps controlled by the same contactor is  $n \cdot \sqrt{3}$ .  
 Electrical life is 100,000 cycles up to 55°C.



## 2 Contactors

### Technical characteristics

#### POWER FACTOR CORRECTION CAPACITORS

##### CHOICE CRITERIA

The contactor during the closing transition is influenced by electrical currents having high frequencies and high amplitudes. The frequencies of these currents range between 1 and 10kHz; the amplitudes must have values lower than the maximum permissible current peak of the contactor to be used.

##### AMBIENT OPERATING CONDITIONS

Ambient temperature:  $\leq 50^\circ\text{C}$ .  
For temperatures higher than  $50^\circ\text{C}$  up to  $70^\circ\text{C}$ , stated maximum operational power ratings are to be reduced by a percentage equal to the difference between the ambient temperature and  $50^\circ\text{C}$ .  
Operating cycle:  $\leq 120$  cy/h  
Electrical life:  $\geq 100,000$  cycles.

Contactor	IEC rated current $\leq 400\text{V}$	Maximum permissible peak current	IEC maximum operational voltage	Fuse	IEC maximum operational power (AC-6b)			
					220V 230V 240V	380V 400V	415V 440V	500V 660/690V
Type	[A]	[A]	[V]	gG	[kvar]	[kvar]	[kvar]	[kvar]
<b>BF09A</b>	12	500	690	16	4.5	7.5	9	10
<b>BF12A</b>	18	550	690	25	7	12.5	12	14
<b>BF18A</b>	23	1000	690	32	9	15	16	18
<b>BF25A</b>	23	1000	690	32	9	15	16	18
<b>BF26A</b>	30	1400	690	40	11	20	22	22
<b>BF32A</b>	36	1700	690	50	14	25	27	30
<b>BF38A</b>	43	1900	690	63	17	30	30	34
<b>BF40A</b>	50	2500	1000	100	20	35	40	45
<b>BF50A</b>	58	2500	1000	80	22	40	41	45
<b>BF65A</b>	65	2500	1000	100	26	45	50	52
<b>BF80A</b>	75	2500	1000	125	30	50	56	70
<b>BF94A</b>	75	2500	1000	125	30	50	56	70
<b>BF95A</b>	90	3000	1000	125	34	60	75	80
<b>BF115A</b>	115	3000	1000	160	45	75	85	135
<b>BF150A</b>	144	3000	1000	160	50	100	115	150
<b>BF160</b>	150	3400	1000	200	57	100	108	130
<b>BF195</b>	170	3600	1000	250	65	112	122	150
<b>BF230</b>	215	4500	1000	315	85	140	150	190
<b>B250</b>	240	5100	1000	315	91	158	172	210
<b>B310</b>	265	5900	1000	315	105	184	200	245
<b>B400</b>	320	7500	1000	400	122	211	230	280
<b>B500</b>	500	9000	1000	630	190	330	360	430
<b>B630</b>	610	11000	1000	800	230	400	432	520

The use of contactors with the above operational powers is allowable only when the peak current, in the installation point of the power factor correction board, is lower than the values stated in the table.

If this condition is not verified, it is necessary to use limiting inductances or specific contactors stated on page 2-16. Consult Technical support (see contact details on inside front cover) to obtain detailed information on the correct use of contactors without limiting inductances.

##### LIMITING INDUCTANCES

The use of limiting inductances is imperative when the system inductances (line transformer and cables), upstream of the power factor correction panel, are not able to maintain the maximum connecting current within the limit value of the contactor used.

##### FAST DISCHARGE RESISTANCES OF CAPACITORS

The use of the contactor, according to the wiring diagram given, allows the fast discharge of the capacitors as well as the instantaneous disconnection of the capacitors from the mains when the coil is de-energised. The resistances, indicated in the following table, guarantee the discharge within a maximum time of 2 seconds.

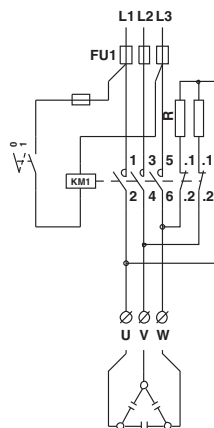

Capacitor power [kvar]	Voltage 220...230V		Voltage 380...500V	
	[ $\Omega$ ]	[W]	[ $\Omega$ ]	[W]
2.5-5	3900	12	8200	12
10-15	1800	25	4300	25
20-50	1000	50	2200	50



# 2 Contactors

## Technical characteristics

### SPECIAL CONTACTORS FOR POWER FACTOR CORRECTION CAPACITORS

#### GENERAL CHARACTERISTICS

These contactors are equipped with early-make contacts. This special type of contact has the purpose of connecting for a very brief interval, 2-3ms, during the contactor closing, resistors which limit the connecting current of the capacitors. These resistors are then excluded when the closing operation is complete and the current capacity is conveyed to the main contacts. With this type of circuit, it is possible to obtain minor wear of all the components of the system especially fuses and capacitors ensuring a longer life and better reliability. The contactors are particularly suitable for use in automatic power factor correction panels since there is no need of limiting inductances and a source of heat has been eliminated. In this way, these modular electric switchboards can be more compact.

The BFK version, figure 1, is designed for three-phase switching. The peculiarity of this type is in the contacts, suitable to connect limiting resistors, which close only for the time needed to limit any in-rush current peak and then reopen to avoid eventual flow of residual currents through the resistors.

#### AMBIENT OPERATING CONDITIONS

Ambient temperature:  $\leq 50^\circ\text{C}$

For ambient temperature higher than  $50^\circ\text{C}$  up to  $70^\circ\text{C}$ , maximum operational power ratings, indicated in the table, are to be reduced by a percentage equal to the difference between the ambient temperature and  $50^\circ\text{C}$ .

Operating cycles:  $\leq 120$  cy/h.

Electrical life:  $\geq 400,000$  cycles.

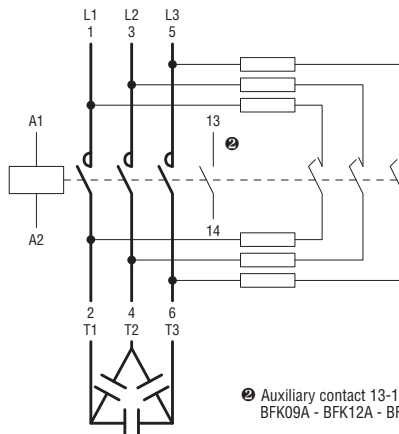

Fig. 1

Ⓜ Auxiliary contact 13-14 is found on BFK09A - BFK12A - BFK18A types only.

Contactor	Built-in auxiliary contacts NO	IEC rated operational current $\leq 440\text{V}$	IEC fuse gG	Maximum IEC power at $\leq 50^\circ\text{C}$ (AC6b) ①			
				220V 230V 240V	380V 400V	415V 440V	500V 690V
Type	n°	[A]	[A]	[kvar]	[kvar]	[kvar]	[kvar]
<b>BFK09A</b>	1	12	16	4.5	7.5	9	10
<b>BFK12A</b>	1	18	25	7	12.5	14	16
<b>BFK18A</b>	1	23	40	9	15	17	20
<b>BFK26A</b>	—	30	40	11	20	22	25
<b>BFK32A</b>	—	36	63	14	25	27.5	30
<b>BFK38A</b>	—	43	63	17	30	33	36
<b>BFK50A</b>	—	58	80	22	40	41	46
<b>BFK65A</b>	—	65	100	26	45	50	56
<b>BFK80A</b>	—	75	125	30	50	56	65
<b>BFK94A</b> Ⓜ	—	90	125	34	60	75	80
<b>BFK95A</b>	—	90	125	34	60	75	80
<b>BFK115A</b>	—	115	160	45	75	85	135
<b>BFK150A</b>	—	144	160	50	100	115	150

NOTE: See page 2-16 for order codes.

① Consult Technical support (Tel. 035 4282422; E-mail: service@LovatoElectric.com) for the use of contactors to switch within delta connection.

Ⓜ Note: The maximum thermal current of the BFK94 contactor is 115A.

#### CHOICE OF CONTACTORS TYPE BFK ACCORDING TO cULus LISTING

Contactor	Built-in auxiliary contacts NO (SPST)	UL/CSA rated current $\leq 440\text{V}$	UL/CSA protection fuse SC/gG	Maximum UL/CSA operational power at voltage:		
				240V	480V	600V
Type	n°	[A]	[A]	[kvar]	[kvar]	[kvar]
<b>BFK09A</b>	1	12	16	4.5	9	10
<b>BFK12A</b>	1	18	25	7	14	16
<b>BFK18A</b>	1	23	40	9	17	20
<b>BFK26A</b>	—	30	40	11	22	27.5
<b>BFK32A</b>	—	36	63	14	27.5	32
<b>BFK38A</b>	—	43	63	17	33	36
<b>BFK50A</b>	—	58	80	22	41	46
<b>BFK65A</b>	—	70	100	26	50	56
<b>BFK80A</b>	—	75	125	30	60	75
<b>BFK95A</b>	—	100	125	40	80	100
<b>BFK115A</b>	—	115	160	45	90	120
<b>BFK150A</b>	—	121	160	50	100	125

NOTE: See page 2-16 for order codes.





# 2 Contactors

## Technical characteristics

### IEC OPERATIONAL CHARACTERISTICS BG00 AND BF00

TYPE		BG00	BF00A	BF00D	BF00L
<b>POLE CONTACT CHARACTERISTICS</b>					
Poles <sup>①</sup>	n°	4			
Conventional free air thermal current I <sub>th</sub> (≤40°C)	A	10			
Rated insulation voltage U <sub>i</sub>	V	690			
Frequency limit	Hz	25...400 <sup>②</sup>			
UL/CSA and IEC/EN/BS 60947-5-1 auxiliary contact designation	AC	A600			
	DC	Q600		P600	
Terminals  Quick-connect	A	7.5		8.3	
	B	4		3.5	
	Screw	M3		M3.5	
	Phillips	2		2	
	Faston	1x6.35 - 2x2.8		—	
Tightening torque for contact terminals min-max	Nm	9		13...16	
	lb.in	0.59-0...74		1.03...1.33	
Tightening torque for coil terminals min-max	Nm		0.8...1		
	lb.in		7...9		
	Phillips		2		
Conductor section connectable with 1 or 2 wires min ... max	AWG stranded	n°	18...12		16...10
	Flexible w/o lug	mm <sup>2</sup>	0.75...2.5		1...6
	Flexible c/w boot-lace ferrule	mm <sup>2</sup>	2x1.5 or 1x2.5		1...4
	Flexible c/w spade lug	mm <sup>2</sup>	2x1.5 or 1x2.5		1...4
Terminal protection according to IEC/EN/BS 60529				IP20 <sup>③</sup>	
<b>AMBIENT CONDITIONS</b>					
Operating temperature	°C	-40...+60		-50...+70	
Storage temperature	°C	-55...+70		-60...+80	
Maximum altitude	m		3000		
Operation position	Normal		On vertical plane		
	Allowable		±30°		
Fixing			Screw or on 35mm DIN rail		

- ① The built-in auxiliary contacts are high-conductivity
- ② Derating for use at 61-400 Hz. Consult technical support for information (Tel. 035 4282422; E-mail: service@LovatoElectric.com).
- ③ IP20 protection warranted by wired equipment; minimum 0.75mm<sup>2</sup> conductor section for BG00 or 1mm<sup>2</sup> for BF00.

### ELECTRICAL RATINGS BASED ON IEC/EN/BS 60947-5-1 UTILIZATION CATEGORIES AND UL508/CSA C22.2 n°14

IEC/EN/BS designation	IEC/EN/BS utilization category	Conventional enclosed thermal current I <sub>the</sub>	Rated operational current I <sub>e</sub> [A] at rated operational voltage U <sub>e</sub>										VA rating	
UL designation	—	Thermal continuous test current	Maximum Amperes (AC) 60Hz										Maximum VA	
Alternating current		[A]	120VAC		240VAC		380VAC		480VAC		600VAC		Make	Break
A600	AC-15	10	60	6	30	3	19	1.9	15	1.5	12	1.2	7200	720
Direct current			Maximum Amperes (DC) Make or Break											
			125VDC		250VDC		301VDC		400VDC		500VDC		600VDC	
P600	DC-13	5	1.1	0.55	0.2 <sup>④</sup>	0.31 <sup>④</sup>	0.27 <sup>④</sup>	0.2	138	138				
Q600	DC-13	2.5	0.55	0.27	0.1 <sup>④</sup>	0.15 <sup>④</sup>	0.13 <sup>④</sup>	0.1	69	69				

- ④ Value at 301V is valid for UL/CSA up to 600VDC; the others are valid for IEC/EN/BS.
- ⑤ Voltage valid for UL/CSA only.



## 2 Contactors

### Technical characteristics

TYPE				BG00	BF00A	BF00D	BF00L			
<b>AC CONTROL</b>										
Rated control voltage at 50/60Hz or 60Hz		V		12...575	12...600	—	—			
<b>Operating voltage limits</b>										
50/60Hz coil powered at	50Hz	pick-up	% Us	75...115	80...110	—	—			
		drop-out	% Us	20...55	20...55	—	—			
	60Hz	pick-up	% Us	80...115	80...110	—	—			
		drop-out	% Us	20...55	20...55	—	—			
60Hz coil powered at	60Hz	pick-up	% Us	75...115	80...110	—	—			
		drop-out	% Us	20...55	20...55	—	—			
<b>Average coil consumption at ≤20°C</b>										
50/60Hz coil powered at	50Hz	in-rush	VA	30	75	—	—			
		holding	VA	4	9	—	—			
	60Hz	in-rush	VA	25	70	—	—			
		holding	VA	3	6.5	—	—			
60Hz coil powered at	60Hz	in-rush	VA	30	75	—	—			
		holding	VA	4	9	—	—			
Dissipation at holding ≤20°C		50Hz	W	0.95	2.5	—	—			
<b>DC CONTROL</b>										
Rated control voltage		V		6...250	—	6...415	6...415			
Operating voltage limits		pick-up	% Us	75...115	—	70...125	80...110			
		drop-out	% Us	10...20	—	10...40	10...40			
Average consumption at ≤20°C (in-rush/holding)		W		3.2 <sup>①</sup>	—	5.4	2.4			
<b>OPERATING TIMES</b>										
Average time for Us control in		AC	closing NO	ms	12...21	8...24	—	—		
			opening NO	ms	9...18	10...20	—	—		
			closing NC	ms	17...26	17...30	—	—		
			opening NC	ms	7...17	7...18	—	—		
		DC	closing NO	ms	18...25	—	54...66	75...91		
			opening NO	ms	2...3	—	14...17	15...19		
			closing NC	ms	3...5	—	24...30 <sup>②</sup>	24...30 <sup>③</sup>		
			opening NC	ms	11...17	—	47...57 <sup>②</sup>	67...81 <sup>③</sup>		
			<b>LIFE</b>							
			Mechanical		AC control	cycles	20 million			
DC control	cycles	20 million								
<b>MAXIMUM OPERATING RATE</b>										
Mechanical operations			cycles/h	3600						

① 2.3W for low-consumption BG00...L version.  
 ② NC closing time for BF0004D is 23...29ms while NC opening time is 40...49ms.  
 ③ NC closing time for BF0004L is 25...31ms while NC opening time is 56...68ms.



## 2 Contactors

### Technical characteristics

#### IEC OPERATIONAL CHARACTERISTICS BG06..., BG09... AND BG12...

TYPE		BG06	BG09	BG12
<b>POLE CHARACTERISTICS</b>				
Power poles	n°	3	3-4	3
Rated insulation voltage $U_i$	V	690	690 ❶	690
Rated impulse withstand voltage $U_{imp}$	kV	6	6	6
Operational frequency	Hz	25...400 ❷	25...400 ❷	25...400 ❷
Operational current	Conventional free air thermal $I_{th}$ ( $\leq 40^\circ\text{C}$ )	A	16	20
	AC3 ( $\leq 440\text{V}$ $\leq 55^\circ\text{C}$ )	A	6	9
	AC4 (400V) ❸	A	3.3	4.0
Short-time allowable current for 10s (IEC/EN/BS 60947-1)	A	96	96	96
Maximum fuse size coordination Type 2 - 400V - 50kA	gG	A	16	20
	aM	A	6	10
Making capacity (RMS value)	A	92	92	120
Breaking capacity at voltage	$\leq 440\text{V}$	A	72	96
	500V	A	72	72
	690V	A	72	72
Consumption per pole and resistance (average values)		mΩ	10	10
	$I_{th}$	W	2.6	4
	AC3	W	0.36	0.81
Terminals		A [mm]	7.5	7.5
		B [mm]	4	4
		screw	M3	M3
		Phillips	2	2
	Quick-connect	Faston	—	1x6.35 - 2x2.8
	Solder	—	—	PIN for PCB ❹
Tightening torque for pole and coil terminals min-max	Nm	0.8...1	0.8...1	0.8...1
	lb.in	9	9	9
	Phillips	2	2	2
Conductor section connectable with 1 or 2 wires min...max	AWG stranded	N°	18...12	
	Flexible w/o lug	mm²	0.75...2.5	
	Flexible c/w boot-lace ferrule	mm²	2x1.5 or 1x2.5	
	Flexible c/w spade lug	mm²	2x1.5 or 1x2.5	
Terminal protection to IEC/EN/BS 60529			IP20 ❺	
<b>AUXILIARY CONTACT CHARACTERISTICS</b>				
Type of contact	n°	1-NO or NC based on configuration ❻		
Thermal current $I_{th}$	A	10		
IEC/EN/BS 60947-5-1 designation	AC	A600		
	DC	Q600		
<b>AMBIENT CONDITIONS</b>				
Operating temperature	°C	-40...+60		
Storage temperature	°C	-55...+70		
Maximum altitude	m	3000		
Operating position	Normal	On vertical plane		
	Allowable	± 30°		
Fixing		Screw or on 35mm DIN rail		

- ❶ Rated voltage  $U_i$  for BGP... types is 500V.
- ❷ Derating for use at 61-400Hz. Consult Technical support for information (Tel. 035 4282422; E-mail: service@LovatoElectric.com).
- ❸ Current values guarantee an electrical life of about 50,000 cycles.
- ❹ Dimensions and drilling distances are given on page 2-36.
- ❺ IP20 protection warranted by wired equipment; minimum 0.75mm² conductor section.
- ❻ NO or NC auxiliary is highly conductive.  
Other characteristics are the same as the mechanical characteristics of the poles.



## 2 Contactors

### Technical characteristics

TYPE		BG06		BG09		BG12	
<b>AC CONTROL</b>							
Rated voltage at 50/60Hz, 60Hz		V		12...575			
<b>Operating voltage limits</b>							
50/60Hz coil powered at	50Hz	pick-up	% Us	75...115			
		drop-out	% Us	20...55			
	60Hz	pick-up	% Us	80...115			
		drop-out	% Us	20...55			
60Hz coil powered at	60Hz	pick-up	% Us	75...115			
		drop-out	% Us	20...55			
<b>Average coil consumption at ≤20°C</b>							
50/60Hz coil powered at	50Hz	in-rush	VA	30			
		holding	VA	4			
	60Hz	in-rush	VA	25			
		holding	VA	3			
60Hz coil powered at	60Hz	in-rush	VA	30			
		holding	VA	4			
Dissipation at ≤20°C at 50Hz		W		0.95			
<b>DC CONTROL</b>							
Rated control voltage		V		6...250			
Operating voltage limits	pick-up	% Us		75...115			
	drop-out	% Us		10...25			
Average consumption at ≤20°C (in rush-holding)		W		3.2	3.2 <sup>①</sup>	3.2	
<b>OPERATING TIMES</b>							
Average time for Us control in	AC	closing NO	ms	12...21	12...21	12...21	
		opening NO	ms	9...18	9...18	9...18	
		closing NC	ms	17...26	17...26	17...26	
		opening NC	ms	7...17	7...17	7...17	
	DC	closing NO	ms	18...25	18...25	18...25	
		opening NO	ms	2...3	2...3	2...3	
		closing NC	ms	3...5	3...5	3...5	
		opening NC	ms	11...17	11...17	11...17	
<b>LIFE</b>							
Mechanical	AC control	cycles		20 million			
	DC control	cycles		20 million			
Electrical (Ie at 400V AC3)		cycles		500,000			
<b>MAXIMUM OPERATING RATE</b>							
Mechanical operations		cy/h		3600			

① 2.3W for low-consumption type BG09...L.

#### ELECTRICAL RATINGS BASED ON IEC/EN/BS 60947-5-1 UTILIZATION CATEGORIES AND UL508/CSA C22.2 n°14

IEC/EN/BS designation	IEC/EN/BS utilization category	Conventional enclosed thermal current Ithe	Rated operational current Ie [A] at rated operational voltage Ue										VA rating	
UL designation	—	Thermal continuous test current	Maximum Amperes (AC) 60Hz										Maximum VA	
			120VAC		240VAC		380VAC		480VAC		600VAC			
Alternating current		[A]	Make	Break	Make	Break	Make	Break	Make	Break	Make	Break	Make	Break
A600	AC-15	10	60	6	30	3	19	1.9	15	1.5	12	1.2	7200	720
Direct current			Maximum Amperes (DC) Make or Break											
			125VDC	250VDC	301VDC	400VDC	500VDC	600VDC					300V or less <sup>②</sup>	
Q600	DC-13	2.5	0.55	0.27	0.1 <sup>③</sup>	0.15 <sup>③</sup>	0.13 <sup>③</sup>	0.1					69	69

② Value at 301V is valid for UL/CSA up to 600VDC; the others are valid for IEC/EN/BS.

③ Voltage valid for UL/CSA only.



# 2 Contactors

## Technical characteristics

### IEC OPERATIONAL CHARACTERISTICS BF09-BF38

TYPE		BF09	BF12	BF18	BF25	BF26	BF32	BF38	
<b>POLE CHARACTERISTICS</b>									
Power poles	n°	3-4	3-4	3-4	3	3-4	3	3-4	
Rated insulation voltage Ui	V	690							
Rated impulse withstand voltage Uimp	kV	6							
Operational frequency	Hz	25...400 <sup>①</sup>							
Operational current	Conventional free air thermal Ith (≤40°C)	A	25	28	32	32	45	56	56(60 <sup>②</sup> )
	AC3 (≤440V ≤55°C)	A	9	12	18	25	26	32	38
	AC4 (400V) <sup>③</sup>	A	4.9	7.9	8.5	10	11.5	13.5	15.5
Short-time allowable current for 10s (IEC/EN/BS 60947-1)	A	150	150	200	200	210	320	320	
Max fuse size coordination Type 2 - 400V - 50kA	gG	A	25	32	32	50	50	63	63
	aM	A	10	12	20	25	32	32	40
Making capacity (RMS value)	A	90	120	180	250	260	320	380	
Breaking capacity at voltage	≤440V	A	72	96	144	200	208	256	304
	500V	A	72	96	120	184	184	240	240
	690V	A	71	94	94	102	168	192	192
Consumption and resistance per pole (average values)		mΩ	2.5	2.5	2.5	2.5	2.0	2.0	2.0
	Ith	W	1.6	2.0	2.6	2.6	4.0	6.0	6.0
	AC3	W	0.2	0.4	0.8	1.6	1.4	2.0	2.9
Terminals	Type	Clamp-screw							
	A	9.5	9.5	9.5	9.5	13	13	13	
	B	4.5	4.5	4.5	4.5	5.5	5.5	5.5	
	Screw	M3.5	M3.5	M3.5	M3.5	M4	M4	M4	
Tightening torque for pole terminal min-max	Nm	1.5...1.8	1,5...1.8	1.5...1.8	1.5...1.8	2.5...3	2.5...3	2.5...3	
		lb.in	13...16	13...16	13...16	13...16	22...27	22...27	22...27
Tightening torque for coil terminals min-max	Nm	0.8...1	0.8...1	0.8...1	0.8...1	0.8...1	0.8...1	0.8...1	
	lb.in	7.1...8.8	7.1...8.8	7.1...8.8	7.1...8.8	7.1...8.8	7.1...8.8	7.1...8.8	
	Phillips	2	2	2	2	2	2	2	
Conductor section connectable with 1 or 2 wires min...max	AWG stranded	n°	16...8	16...8	16...8	16...8	14...6	14...6	14...6
	Flexible w/o lug	mm²	1...6	1...6	1...6	1...6	2.5...16	2.5...16	2.5...16
	Flexible c/w insulated boot-lace ferrule	mm²	1...4	1...4	1...4	1...4	1...10	1...10	1...10
	Flexible c/w insulated spade lug	mm²	1...4	1...4	1...4	1...4	1...10	1...10	1...10
Power terminal protection according to IEC/EN/BS 60529		IP20 <sup>④</sup>	IP20 <sup>⑤</sup>	IP20 <sup>⑥</sup>	IP20 <sup>⑥</sup>	IP20 <sup>④</sup>	IP20 <sup>④</sup>	IP20 <sup>④</sup>	



### AUXILIARY CONTACT CHARACTERISTICS

Type of contact	n°	1-NO or NC based on configuration <sup>⑦</sup>					—
Thermal current Ith	A	10					—
IEC/EN/BS 60947-5-1 designation	AC	A600					—
	DC	P600					—

### AMBIENT CONDITIONS

Operating temperature	°C	-50...+70					
Storage temperature	°C	-60...+80					
Maximum altitude	m	3000					
Operating position	Normal	On vertical plane					
	Allowable	± 30°					
Fixing		Screw or on 35mm DIN rail					

Products certified by UL / CSA as Elevator Equipment.

Type	Maximum horsepower ratings					
	Single phase 120V		Three phase 200-208V			
	240V	240V	240V	480V	600V	600V
	[HP]	[HP]	[HP]	[HP]	[HP]	[HP]
BF12 <sup>⑦</sup>	1/2	1 1/2	3	3	7 1/2	7 1/2
BF25 <sup>⑦</sup>	1 1/2	3	5	7 1/2	15	15
BF38 <sup>⑦</sup>	3	5	10	10	20	20
BF65 <sup>⑧</sup>	3	10	15	15	40	50
BF95 <sup>⑧</sup>	7.5	15	25	30	60	75
BF115 <sup>⑧</sup>	—	—	30	40	75	100
BF150 <sup>⑧</sup>	—	—	30	40	75	100

- ① Derating for use at 61-400Hz. Consult Technical support for information; see contact details on inside front cover.
- ② Current values guarantee an electrical life of about 200,000 cycles.
- ③ IP20 protection warranted by wired equipment; minimum 1mm² conductor section.
- ④ IP20 protection on front.
- ⑤ For this other current value, use 16mm² wire with spade cable terminal.
- ⑥ NO or NC auxiliary is highly conductive. Other characteristics are the same as the mechanical characteristics of the poles.
- ⑦ Elevator equipment by CSA (file LR54332-23) 500,000 operations.
- ⑧ Elevator equipment by cULus (file E93602) 500,000 operations.





## 2 Contactors

### Technical characteristics

TYPE	BF09	BF12	BF18	BF25	BF26	BF32	BF38
<b>AC CONTROL</b>							
Rated voltage at 50/60Hz, 60Hz	V			12...600			
<b>Operating voltage limits</b>							
50/60Hz coil powered at	50Hz	pick-up	% Us	80...110			
		drop-out	% Us	20...55			
	60Hz	pick-up	% Us	85...110			
		drop-out	% Us	20...55			
60Hz coil powered at	60Hz	pick-up	% Us	80...110			
		drop-out	% Us	20...55			
<b>Average coil consumption at ≤20°C</b>							
50/60Hz coil powered at	50Hz	in-rush	VA	75			
		holding	VA	9			
	60Hz	in-rush	VA	70			
		holding	VA	6.5			
60Hz coil powered at 60Hz	60Hz	in-rush	VA	75			
		holding	VA	9			
Dissipation at holding ≤20°C	50Hz	W	2.5				

<b>DC CONTROL - normal and low consumption</b>							
Rated control voltage	V			6...415			
<b>Operating limits</b>							
pick-up	three-pole BF...D	from	% Us	70			
		to	% Us	125			
	four-pole BF...D	from	%Us	70		80	
		to	%Us	125		125	
	three and four pole BF...L	from	% Us	80			
		to	% Us	110			
drop-out for all versions	from	%Us	10				
	to	%Us	40				
Average coil consumption ≤20°C (in rush-holding)	BF...D	W	5.4				
	BF...L	W	2.4				

<b>OPERATING TIMES</b>									
Average time for AC Us control in	closing NO	ms	8...24				8...24		
		opening NO	ms	10...20				5...15	
		closing NC	ms	14...28 <sup>①</sup>				9...20 <sup>②</sup>	
		opening NC	ms	7...18 <sup>①</sup>				9...17 <sup>②</sup>	
	DC BF...D types	closing NO	ms	54...66				53...65	
		opening NO	ms	14...17				14...18	
		closing NC	ms	24...30 <sup>③</sup>				23...28	
		opening NC	ms	47...57 <sup>③</sup>				46...56	
	DC BF...L types	closing NO	ms	75...91				76...92	
		opening NO	ms	15...19				16...20	
		closing NC	ms	24...30 <sup>④</sup>				25...31	
		opening NC	ms	67...81 <sup>④</sup>				63...77	

<b>LIFE</b>								
Mechanical (million)	AC control	cycles	20	20	20	20	20	20
	DC control	cycles	20	20	20	20	20	20
Electrical (1e at 400VAC3) (million)		cycles	2.0	2.0	1.6	1.2	1.6	1.4

<b>MAXIMUM OPERATING RATE</b>								
Mechanical operations	cy/h	3600						

- ① NC closing time for BF...TOA types is 9...25ms while NC opening time is 9...15ms.
- ② NC closing time for BF...TOA types is 11...29ms while NC opening time is 6...14ms.
- ③ NC closing time for BF...TOD types is 23...29ms while NC opening time is 40...49ms.
- ④ NC closing time for BF...TOL types is 25...31ms while NC opening time is 56...68ms.

**ELECTRICAL RATINGS BASED ON IEC/EN/BS 60947-5-1 UTILIZATION CATEGORIES AND UL508/CSA C22.2 n°14**

IEC/EN/BS designation	IEC/EN/BS utilization category	Conventional enclosed thermal current Ithe	Rated operational current Ie [A] at rated operational voltage Ue										VA rating	
UL designation	—	Thermal continuous test current	Maximum Amperes (AC) 60Hz										Maximum VA	
			120VAC		240VAC		380VAC		480VAC		600VAC			
			Make	Break	Make	Break	Make	Break	Make	Break	Make	Break	Make	Break
A600	AC-15	10	60	6	30	3	19	1.9	15	1.5	12	1.2	7200	720
Direct current			Maximum Amperes (DC) Make or Break											
			125VDC	250VDC	301VDC	400VDC	500VDC	600VDC						
P600	DC-13	5	1.1	0.55	0.2	0.31	0.27	0.2	300V or less					
			138	138										



## 2 Contactors

### Technical characteristics

#### IEC OPERATIONAL CHARACTERISTICS BF40...BF150...

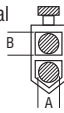
TYPE		BF40	BF50	BF65	BF80	BF94	BF95	BF115	BF150	
<b>POLE CHARACTERISTICS</b>										
Power poles	N°	3-4	3-4	3-4	3-4	3	3-4	3-4	3-4	
Rated insulation voltage $U_i$	V	1000								
Rated impulse withstand voltage $U_{imp}$	kV	8								
Operational frequency	Hz	25 ... 400 <sup>①</sup>								
Operational current	Conventional free air thermal $I_{th}$ ( $\leq 40^\circ\text{C}$ )	A	70	90	100	115	115	140	160	165
	AC3 ( $\leq 440\text{V}$ $\leq 55^\circ\text{C}$ )	A	40	50	65	80	95	95	115	150
	AC4 (400V) <sup>②</sup>	A	24	28	31	38	45	45	54	70
Short-time allowable current for (IEC/EN/BS 60947-1)	10s	A	400	400	640	640	640	760	920	1200
Maximum fuse size coordination Type 2 - 400V - 50kA	gG	A	100	100	125	125	125	160	200	250
	aM	A	50	50	80	80	100	100	125	160
Making capacity (RMS value)	A	400	500	650	800	950	1200	1500	1500	
Breaking capacity at voltage	$\leq 440\text{V}$	A	320	400	520	640	760	1100	1200	1200
	500V	A	265	352	425	625	660	775	850	1025
	690V	A	256	312	376	456	475	745	905	905
Consumption and resistance per pole (average values)	m $\Omega$		0.8	0.8	0.8	0.6	0.6	0.45	0.45	0.45
	$I_{th}$	W	3.9	6.5	8.0	7.9	7.9	8.8	11.5	12
	AC3	W	1.3	2.0	3.4	3.8	5.4	4.1	6.0	10.1
Terminals	Type	Double lug clamp terminal 								
	A [mm]	9.5								
	B [mm]	11								
	Screw	M6								
	Metric Allen	4								
	Tightening torque for pole terminal min-max	Nm	4...5							
	lb.in	35.4...44.3								
Tightening torque for coil terminals min-max	Nm	0.8...1								
	lb.in	7.1...8.8								
	Phillips	2								
Conductor section connectable with 1 or 2 wires min...max	AWG	N°	14...2						14...2/0	
	Flexible w/o lug	mm <sup>2</sup>	1.5...35						1.5...70	
	Flexible c/w lug	mm <sup>2</sup>	1.5...35						1.5...70	
Power terminal protection according to IEC/EN/BS 60529		IP20 front								
<b>AMBIENT CONDITIONS</b>										
Operating temperature	°C	-50...+70 <sup>③</sup>								
Storage temperature	°C	-60...+80 <sup>④</sup>								
Maximum altitude	m	3000								
Operating position	Normal	On vertical plane								
	Allowable	$\pm 30^\circ$								
Fixing		Screw or on 35mm DIN rail					Screw or on 35mm DIN rail <sup>⑤</sup>			

- ① Derating for use at 61-400 Hz. Consult Technical support for information; see contact details on inside front cover.
- ② Current values guarantee an electrical life of about 200,000 cycles.
- ③ -40...+70 for BF40...150E.
- ④ -50...+80 for BF40...150E.
- ⑤ Din rail height 15mm (TH35-15)

Products certified by UL / CSA as Elevator Equipment.  
See table on page 2-70.



## 2 Contactors

### Technical characteristics

TYPE				BF40	BF50	BF65	BF80	BF94	BF95	BF115	BF150
<b>AC CONTROL</b>											
Rated voltage at 50/60Hz, 60Hz		V		12...600 (20...250 electronically controlled AC/DC coil)							
Operating voltage limits											
50/60Hz coil powered at	50Hz	pick-up	% Us	80...110 ①							
		drop-out	% Us	20...55 (≤70% electronically controlled AC/DC coil)							
60Hz coil powered at	60Hz	pick-up	% Us	85...110 ①							
		drop-out	% Us	40...55 (≤70% electronically controlled AC/DC coil)							
Average coil consumption at ≤20°C											
50/60Hz coil powered at	50Hz	in-rush	VA	210 (35...120 electronically controlled AC/DC coil)				300 (70...175 electronically controlled AC/DC coil)			
		holding	VA	15 (1.5...3.7 electronically controlled AC/DC coil)				20 (1.7...3.5 electronically controlled AC/DC coil)			
	60Hz	in-rush	VA	195 (35...120 electronically controlled AC/DC coil)				275 (70...175 electronically controlled AC/DC coil)			
		holding	VA	13 (1.5...3.7 electronically controlled AC/DC coil)				17 (1.7...3.5 electronically controlled AC/DC coil)			
60Hz coil powered at	60Hz	in-rush	VA	210				300			
		holding	VA	15				20			
Dissipation at ≤20°C		50Hz	W	5 (1...2.5 electronically controlled AC/DC coil)				6.5 (1.5...3 electronically controlled AC/DC coil)			
<b>DC CONTROL</b>											
Rated voltage		V		20...250							
Operating voltage limits	pick-up	% Us		80...110 ①							
	drop-up	% Us		≤75% Us min							
Average consumption ≤20°C (in rush-holding)		W		23...68 / 1.2...1.9				70...80 / 1.3...1.5			
<b>OPERATING TIMES</b>											
Average time for Us control in	AC	closing NO	ms	12...28 (40...85 electronically controlled AC/DC coil)				16...32 (45...90 electronically controlled AC/DC coil)			
		opening NO	ms	8...22 (20...55 electronically controlled AC/DC coil)				9...24 (24...60 electronically controlled AC/DC coil)			
	DC	closing NO	ms	40...85 (electronically controlled AC/DC coil)				45...90 (electronically controlled AC/DC coil)			
		opening NO	ms	20...55 (electronically controlled AC/DC coil)				24...60 (electronically controlled AC/DC coil)			
<b>LIFE</b>											
Mechanical (million)	AC control	cycles	15	15	15	15	15	15	15	15	15
	DC control	cycles	15	15	15	15	15	15	15	15	15
Electrical (Ie at 400V in AC3) (million)		cycles	1.5	1.4	1.4	1.3	1.1	1.4	1.2	0.8	
<b>MAXIMUM OPERATING RATE</b>											
Mechanical operations		cy/h		1500 (2000 for BF40...E...BF150...E...)							

① For electronically controlled AC/DC coils 80% of Us min. and 110% of Us max; for 20...48V 85% of Us min when powered in AC; 77% of Us min for 100...250V coils.  
 ② Electromagnetic compatibility: BF40...94E contactors with electronic coil 20...48VAC/DC are in compliance with IEC/EN/BS 60947-1 and IEC/EN/BS 60947-1 standards for Environment B (domestic). The other devices are in compliance for Environment A (industrial) and can be upgraded to Environment B connecting proper filters; consult Technical support for information - see contact details on inside front cover.



# 2 Contactors

## Technical characteristics

### IEC OPERATIONAL CHARACTERISTICS BF160...BF230 and B250...B1600

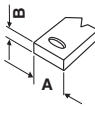
TYPE		BF160	BF195	BF230	B250	B310	B400	B500	B630	B630 1000	B1250	B1600		
<b>POLE CHARACTERISTICS</b>														
Power poles	n°	3-4	3-4	3-4	3-4	3-4	3-4	3-4	3-4	3-4	3-4	3-4		
Rated insulation voltage $U_i$	V	1000												
Rated impulse withstand voltage $U_{imp}$	kV	8												
Operational frequency	Hz	25-400 <sup>①</sup>												
Operational current Conventional free air thermal lth ( $\leq 40^\circ\text{C}$ )	A	250	275	350	350	450	550	700	800	1000	1250	1600		
	AC3 ( $\leq 440\text{V}$ $\leq 55^\circ\text{C}$ )	A	160	195	230	265	320	420	520	630	-	-		
	AC4 (400V) <sup>②</sup>	A	56	68	80	92	110	133	175	210	-	-		
Short-time allowable current for 10s (IEC/EN/BS 60947-1)	A	1280	1560	1840	2200	2900	3600	4050	5040	5600	6500	8300		
Maximum fuse size coordination Type 2 - 400V - 50kA	gG	A	315	315	400	400	500	630	800	1000	1000	1250	1600	
	aM	A	200	250	250	250	400	400	500	630	-	-	-	
Making capacity (RMS value)	A	1360	1658	1955	2750	3150	4200	5000	6300	6300	6300	6300		
Breaking capacity at voltage	$\leq 440\text{V}$	A	1360	1658	1955	2500	3000	4000	5000	6300	6300	6300		
	500V	A	1326	1326	1564	2250	2700	3400	4500	5600	5600	5600		
	690V	A	1139	1377	1377	2200	2520	3360	4000	5000	5000	5000		
	1000V	A	468	553	638	1500	1700	2300	2700	3400	3400	3400		
Consumption and resistance per pole (average values)	mΩ	0.18	0.18	0.18	0.20	0.20	0.20	0.14	0.14	0.14	0.07	0.07		
	lth	W	11	13	21	24.5	40.5	52.0	68.6	90	140	110	180	
	AC3	W	4.5	6.7	9.3	12.5	20	32	35.0	56	-	-		
Terminals		A mm	18	18	18	25	25	25	35	40	60	80	80	
		B mm	5	5	5	5	5	5	5	6	6	6	10	10
		Screw + hex nut	M8	M8	M8	M10	M10	M10	M10	M10	M12	2xM12	2xM12	2xM12
		Key mm	13	13	13	17	17	17	17	19	19	19	19	
		Coil terminals	Type	Screw			Faston 1x6.35 o 2x2.8							
Pole tightening torque	Nm	18	18	18	35	35	35	35	55	55	55	55		
	lb.in	159	159	159	310	310	310	310	486	486	486	486		
Tightening torque for coil terminals min-max	Nm	0.8...1			0.8...1 <sup>③</sup>									
	lb.in	7.1...8.8			7.1...8.8 <sup>③</sup>									
	Phillips	2			2 <sup>③</sup>									
Maximum conductor section	mm	25x5	25x5	25x5	30x4	30x5	30x5	50x5	60x5	60x5	100x5	100x5		
	N° 1 wire with lug	mm <sup>2</sup>	185			240	-	-	-	-	-	-	-	
	N° 2 wire with lug	mm <sup>2</sup>	185			-	150	150	240	240	-	-	-	
<b>AMBIENT CONDITIONS</b>														
Operating temperature	°C	-40...+70				-50...+70				-20...+60				
Storage temperature	°C	-50...+80				-60...+80				-30...+80				
Maximum altitude	m	3000												
Operating position	Normal							Vertical						
	Allowable							± 30°						
Fixing		Screw												

① Derating for use at 61-400 Hz. Consult Technical support for information (Tel. 035 4282422; E-mail: service@LovatoElectric.com).  
 ② Current values guarantee an electrical life of about 200,000 cycles.  
 ③ G371: Adapter to transform coil faston terminals into screw type.



# 2 Contactors

## Technical characteristics

TYPE		BF160	BF195	BF230	B250	B310	B400	B500	B630	B630 1000	B1250	B1600
<b>AC CONTROL</b>												
Supply voltage		50/60Hz, DC			Either in AC/DC						Only AC	
Rated control voltage	V	20...500			24...480	24...480	24...480	48...480	48...480	48...480	110/240	110/240
Operating voltage limits	pick-up	% Us	80...110			80...110	80...110	80...110	80...110	80...110	80...110	80...110
	drop-out	% Us	≤70% Us min			20...60	20...60	20...60	20...60	20...60	20...60	20...60
Consumption at ≤20°C	in-rush	VA/W	160...230			300	300	300	400	400	400	800
	holding	VA/W	1.5...3.0			10	10	10	18	18	18	45
Dissipation at ≤20°C	W	1.5...3.0			10	10	10	18	18	18	40	
<b>OPERATING TIMES</b>												
Making	ms	50...100			80...120	80...120	80...120	110...180	110...180	110...180	120...210	300...450
Breaking	ms	30...75			30...75	30...75	30...75	60...100	60...100	60...110	70...130	70...130
<b>LIFE</b>												
Mechanical (million)	AC/DC	cycles	10	10	10	10	10	10	5	5	5	5
Electrical (million) (Ie at 400V in AC3)		cycles	1	1	1	1	0.9	0.7	0.7	0.7	-	-
<b>MAXIMUM OPERATING RATE</b>												
Mechanical operations	cy/h	1000			2400			1200				
<b>PARTICULAR CHARACTERISTICS</b>												
Indicator		For contactor open or closed status										

● 80% of Us min and 110% of Us max.

### CONTROL CIRCUIT UTILISATION

The input electronic circuit of the contactor coil B250-B1600 is designed and tested according to IEEEC 62.41 and can withstand a 10 kV impulse voltage (1.2/50µs) with 50 Joule energy. For higher values, the use of an auxiliary step-down voltage transformer is recommended.

### CONTACTORS WITH MECHANICAL LATCH

Contactors B250-B630 type, can have mechanical latch included or can be predisposed, to be completed with mechanical latch, see pages 2-6 and 2-8 (3-pole version) or 2-10 and 2-12 (4-pole version). Technical data of mechanical latch G495 type is stated on page 2-30.







## 2 Contactors

### Technical characteristics

#### MECHANICAL INTERLOCK BETWEEN CONTACTORS ONE ON TOP OF THE OTHER B250...B1600... (Fig. 1, 2 and 3)

It is G356... type, which is provided in six types to allow different fixing interaxis of contactors.

Contactors of the same size can be interlocked as well as different sizes.

#### INTERAXIS A [mm] - For contactors with terminal protection (Fig. 1)

KM1	B250-B310-B400		B500-B630	
	B250 B310 B400	B500 B630	B250 B310 B400	B500 B630
G3562	--	--	--	--
G3563	--	--	--	--
G3564	372...385	--	--	--
G3565	390...425	420...425	420...425	--
G3566	470...500	470...500	470...500	470...500

To interlock two contactors B6301000, use type G3566 only.  
To interlock two contactors B1250 or B1600, it is imperative to use two pieces of type G3566 (fig. 3), one fixed on the left side and the other on the right.

The tables below indicate the interaxis which can be obtained with the various interlock types; with terminal protections (INTERAXIS A) and without terminal protection (INTERAXIS B).

#### INTERAXIS B [mm] - For contactors without terminal protection (Fig. 2)

KM1	B250-B310-B400		B500-B630	
	B250 B310 B400	B500 B630	B250 B310 B400	B500 B630
G3562	265...305	--	--	--
G3563	305...345	305...345	305...345	--
G3564	345...385	345...385	345...385	345...385
G3565	390...425	390...425	390...425	390...425
G3566	470...500	470...500	470...500	470...500

Interaxis B is 470-500mm for B630 1000, B1250 or B1600.  
The B1250 or B1600 cannot be interlocked with the other types of the B series.

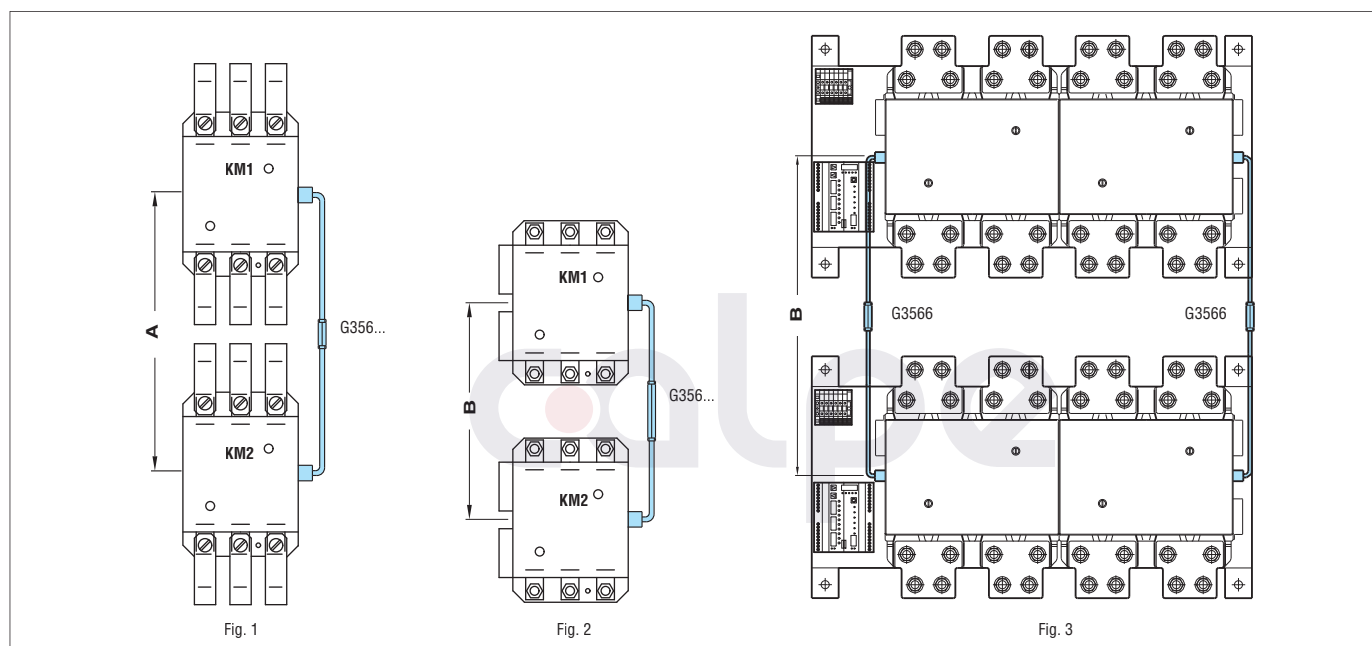

## 2 Contactors

### Technical characteristics

Horizontal and vertical interlock between contactors B250...B630. It is G355 type and can interlock both contactors of equal size and contactors of different sizes (e.g. B250 can be interlocked with B630). For contactor B630 1000 (three-pole), contact our Technical support office. This interlock cannot be applied to contactors B1250-B1600.

Admissible mounting positions for 11G350 and 11G354 auxiliary contacts on contactors equipped with mechanical interlock:

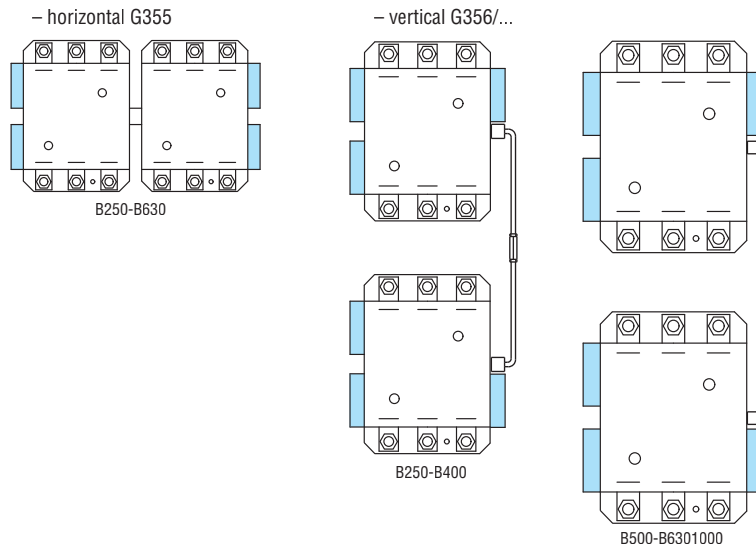

Admissible mounting positions for 11G358 adapter on contactors equipped with mechanical interlock:

